

CESSNA 402 CONV TO SINGLE TURBO

DRAWN BY TOM AKERY 13 OCT 24

27" SPAN RUBBER POWER

CHECK OUT stickandtissue.com
FreeFlightArchive.com &
hippocketaeronautics.com

To date 4 Cessna 402 were converted
 two have crashed and two are still
 flying. Reason for conversion is weight
 saving which enlarges load carrying capacity
 and speed increase. One crash was due to locking
 rudder that wasn't disabled after conversion.

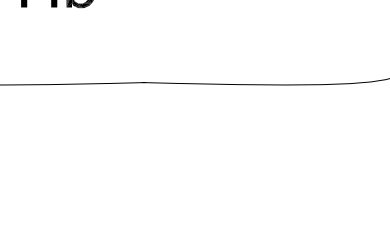
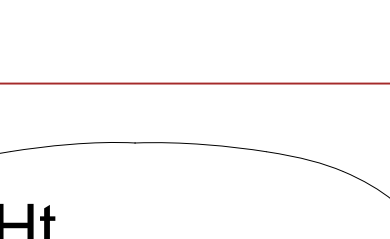
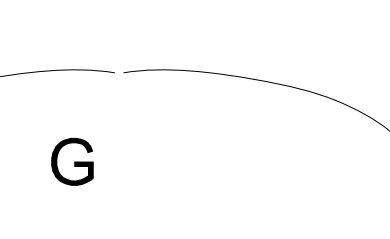
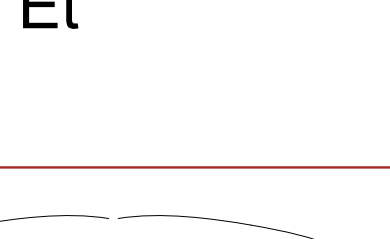
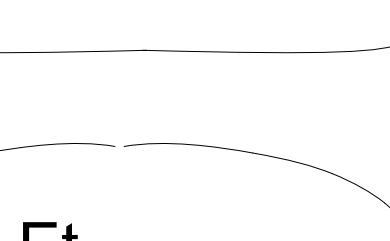
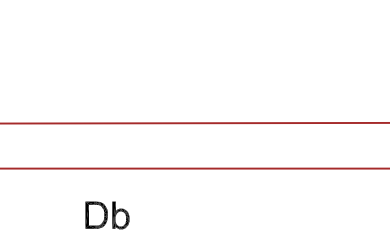
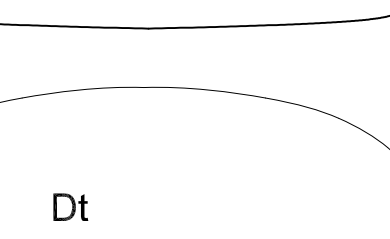
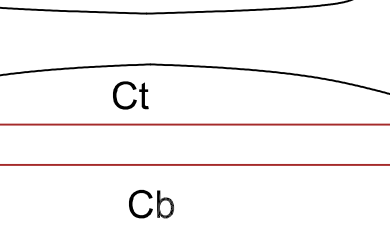
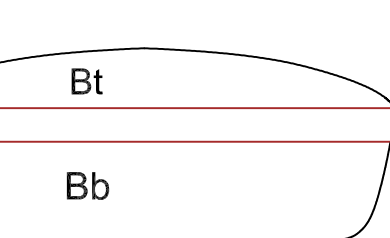
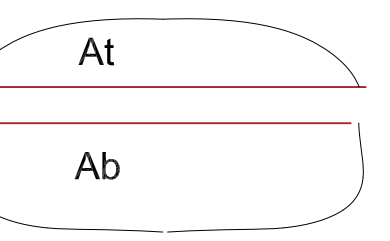
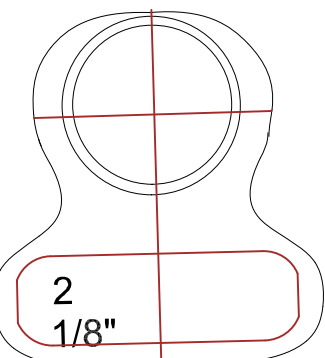
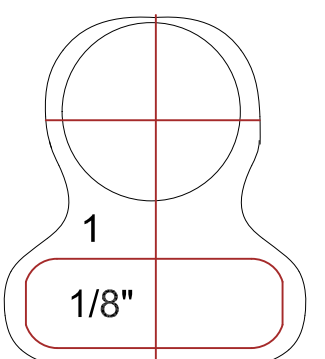
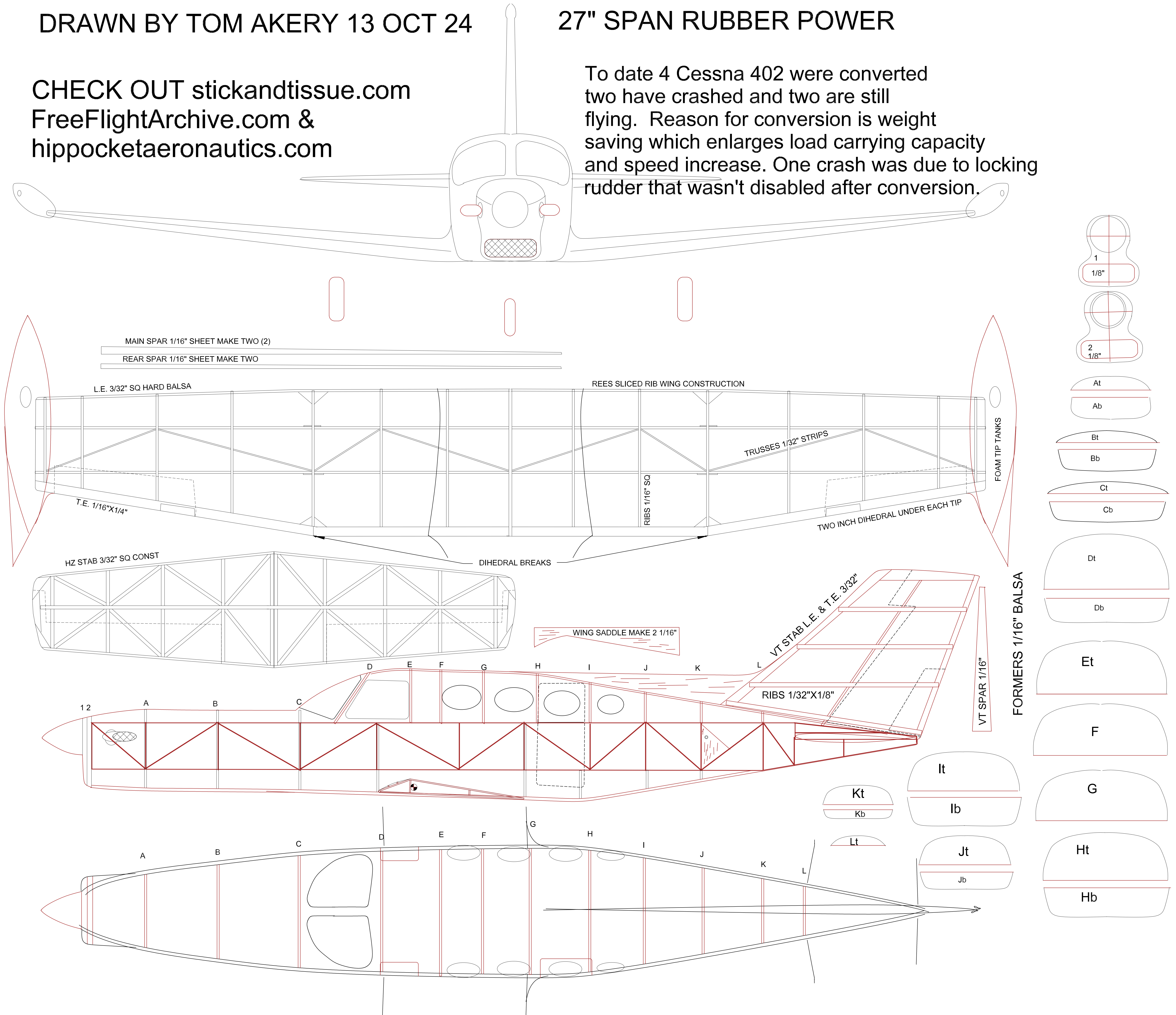

FORMERS 1/16" Balsa

VT SPAR 1/16"

FOAM TIP TANKS

