

MODEL REPRESENTS A P-47D-23 OF THE 23rd FS, 36th FG, 9th AF RAF KINGSNORTH 1944.

COLOR SCHEME
UPPER SURFACES OLIVE DRAB. LOWER SURFACES NEUTRAL GREY. NOSE RING BLACK WITH BRIGHT YELLOW COWL AND OD COWL FLAPS. ENTIRE TAIL UNIT BRIGHT YELLOW WITH BLACK STRIPE ON FIN, BLACK A/C SERIAL AND BLACK "EASY'S ANGELS" ART WORK. A/C CODE LETTERS WHITE.

NOSE PLUG DETAIL



INSERT FROM 3 PLYS 1/8" SHT.

1/32" PLY DISC

HARD BALSAM BOSS

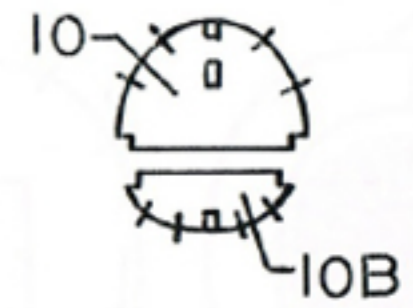
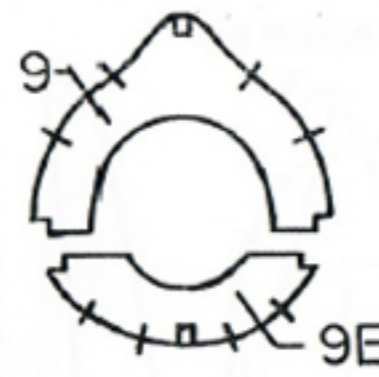

ALL WOOD BALSAM UNLESS SPECIFIED OTHERWISE

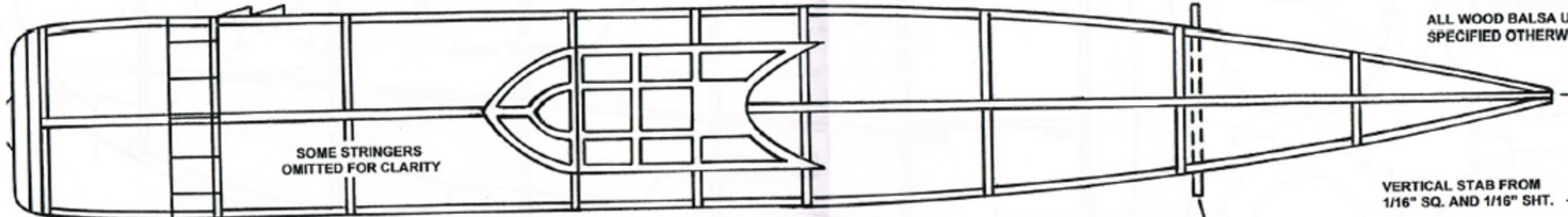

SOME STRINGERS OMITTED FOR CLARITY

3/32" OD ALUM. TUBE

VERTICAL STAB FROM 1/16" SQ. AND 1/16" SHT.

USE 7" PROP

PLUNGE MOLD CANOPY FROM ACETATE

ALL LONGERONS, STRINGERS, UPRIGHTS & CROSSPIECES FROM 1/16" SQ.

RADIO MAST FROM THIN PLASTIC

NOTE A/C CODE ON RIGHT SIDE OF FUSE P+7U

FACN #270

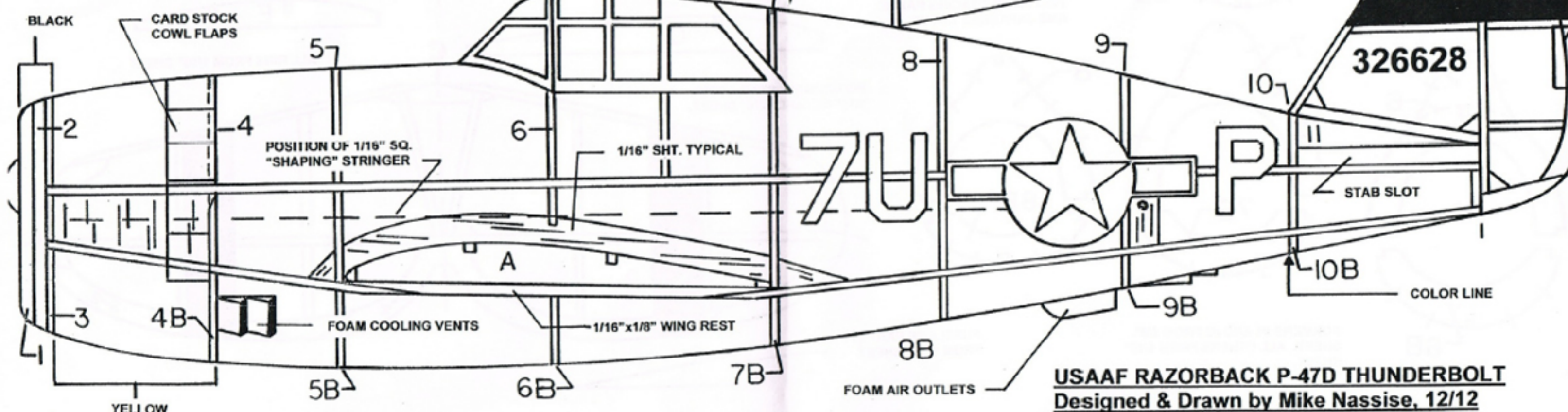

BLACK CARD STOCK COWL FLAPS

POSITION OF 1/16" SQ. "SHAPING" STRINGER

1/16" SHT. TYPICAL

EASY'S ANGELS

326628

STAB SLOT

COLOR LINE

YELLOW

FOAM COOLING VENTS

1/16"x1/8" WING REST

FOAM AIR OUTLETS

USAAF RAZORBACK P-47D THUNDERBOLT
Designed & Drawn by Mike Nassise, 12/12
Wingspan 20" Length 16 3/4"

ALL RIGHTS RESERVED © 2012 M. NASSISE

NO NOTCHES FORMERS #1 & #2.

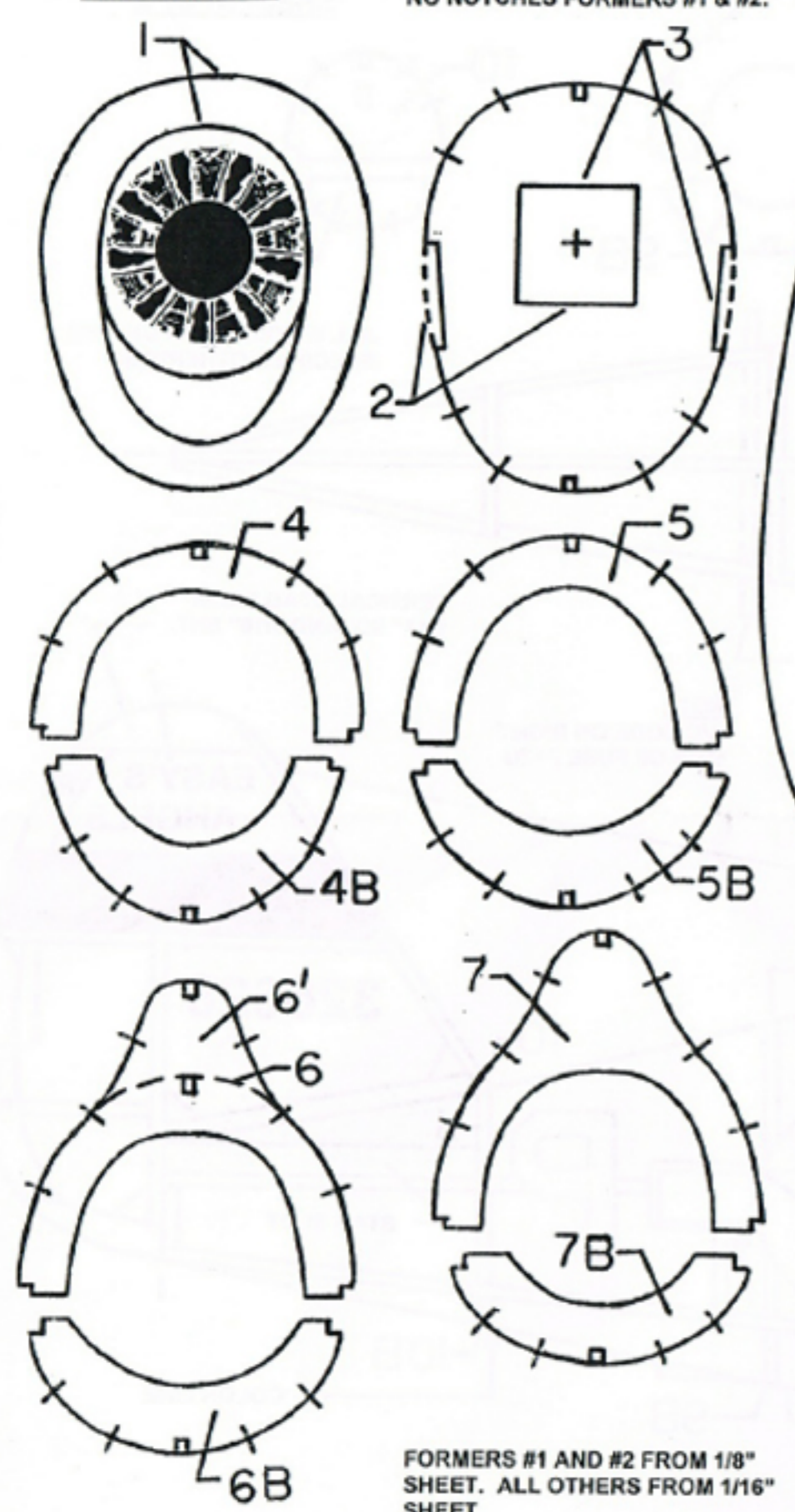

FORMERS #1 AND #2 FROM 1/8" SHEET. ALL OTHERS FROM 1/16" SHEET.

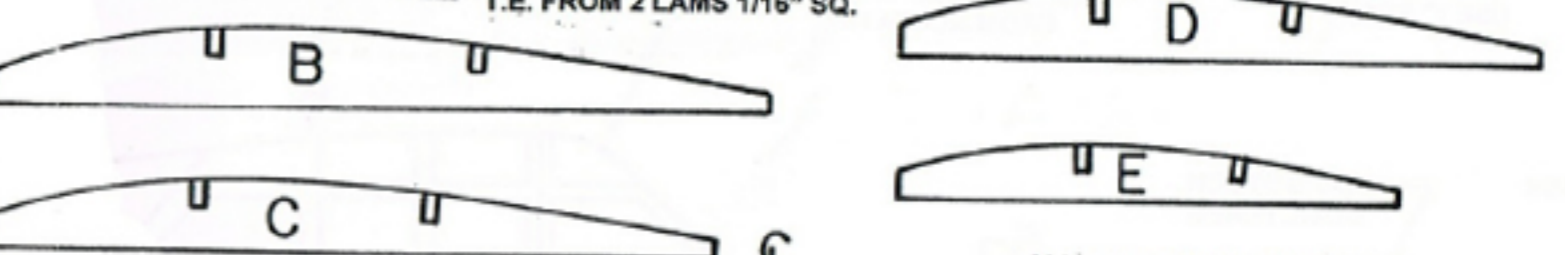
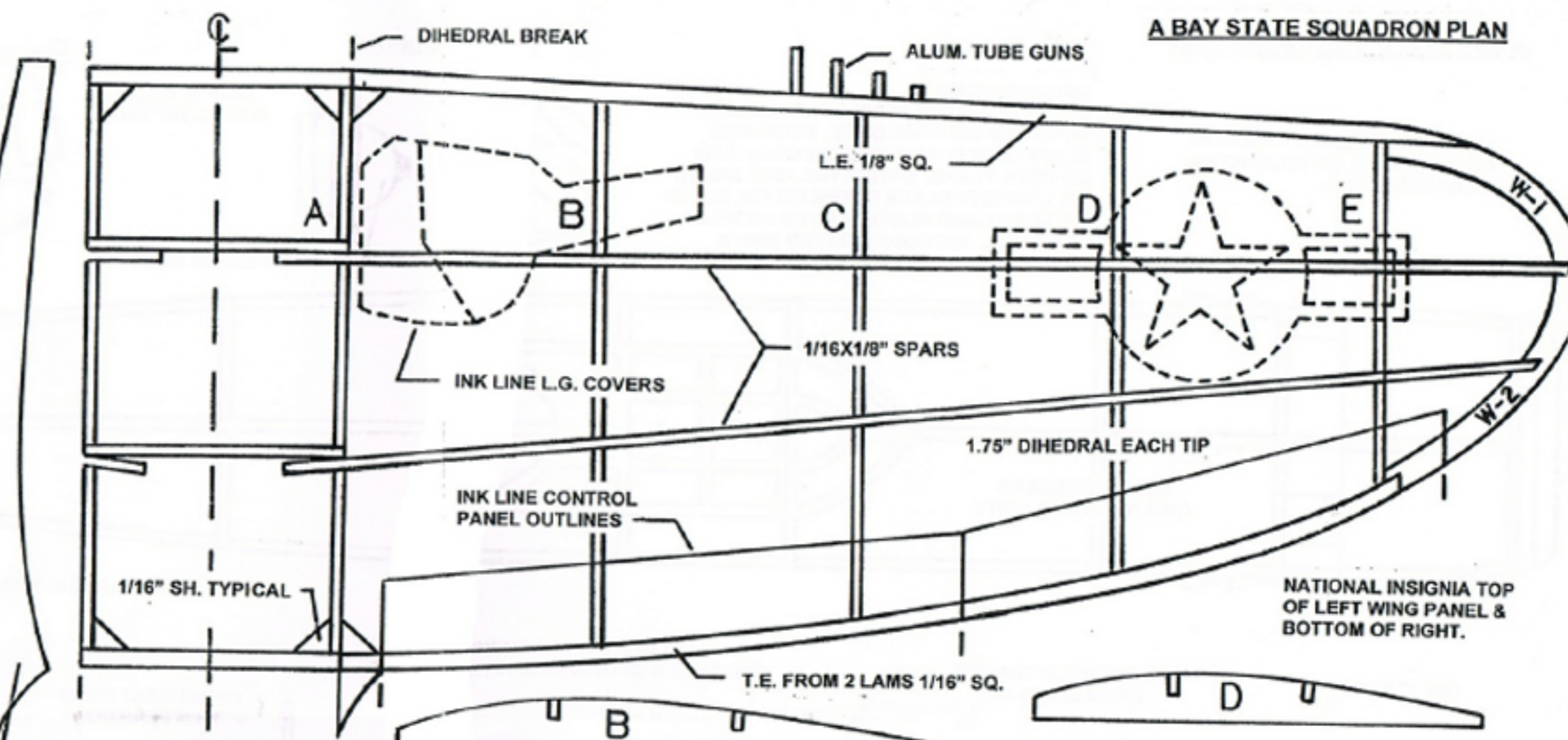

WING FILLET PATTERN - MAKE TWO FROM TRACING PAPER AND JAPANESE TISSUE.

HORIZONTAL STAB FROM 1/16" SQ. AND 1/16" SHEET.

ALL RIBS FROM 1/16" SHEET

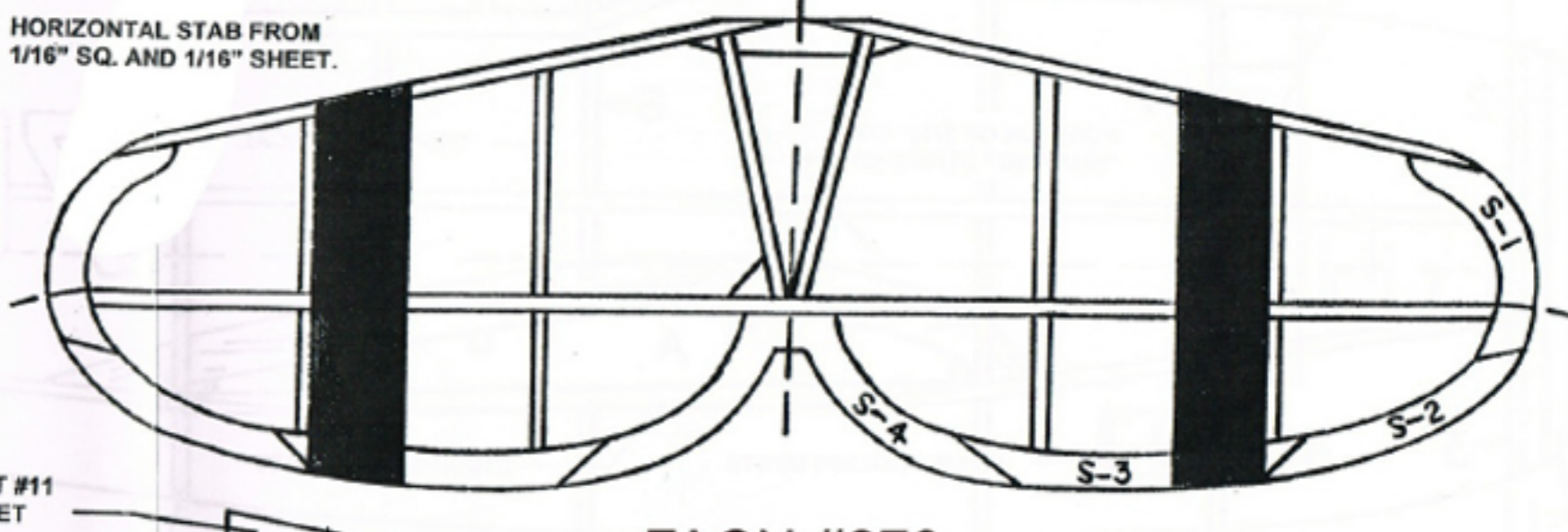

FUSELAGE PART #11 FROM 1/16" SHEET

FACN #270