

DATA FROM
 DON FAIRBANKS
 CARDINAL AIR TRAINING, INC.
 AND
 VERNON PAYNE
 KNIGHT TWISTER AIRCRAFT
 RT. 4, BOX 319M
 ESCONDIDO, CALIF. 92025

DRAWING APPROVED BY
 DON FAIRBANKS, PILOT/OWNER.

DON FAIRBANKS
 KNIGHT TWISTER IMPERIAL
 WING AREA 75 SQ. FT. PLUS FUSELAGE (82 FT.)
 POWER - LYCOMING O-290-D2
 COLOR - WHITE, ORANGE TRIM
 1971 RACING SEASON:
 WILSON N.C. TRIAL - 1ST.
 CAPE MAY N.J. 3RD IN FINAL, 158.4 MPH
 WON TWO HEATS, TRIM AS SHOWN.
 RENO, NEV. - NO 5 PAINTED AS N5DF
 MAY 1971 NO.5D SHOWN BELOW.
 NACA 21 AIRFOIL - .10

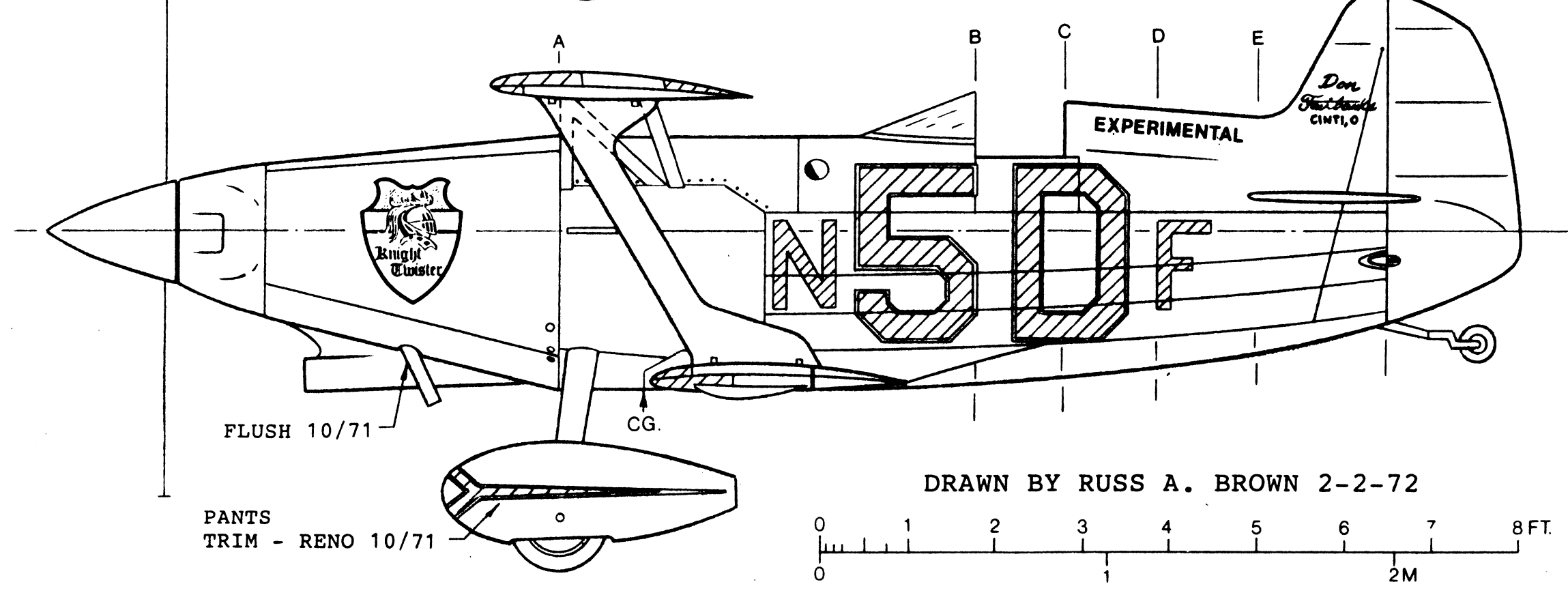

DRAWN BY RUSS A. BROWN 2-2-72

Russ A. Brown