

GLOBE
SWIFT
KIT
SHEET 1/16

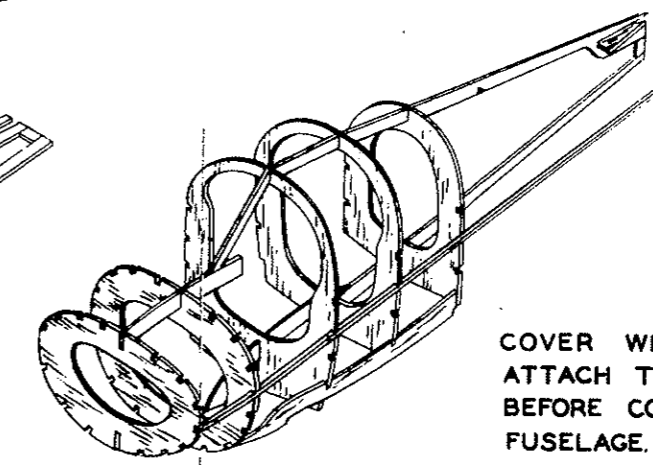

GLOBE
Swift

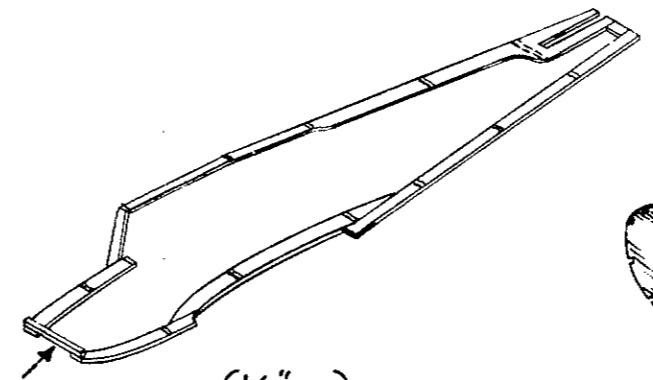
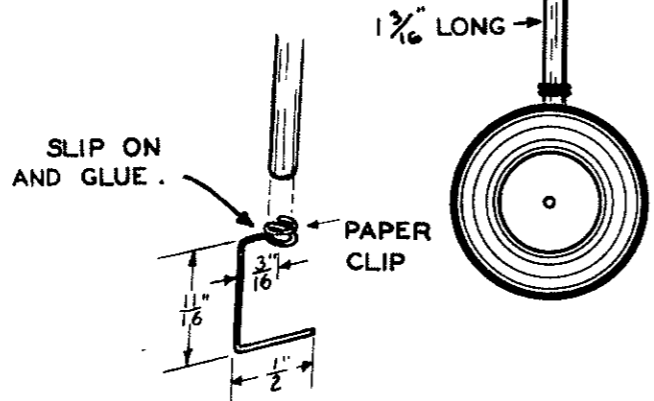
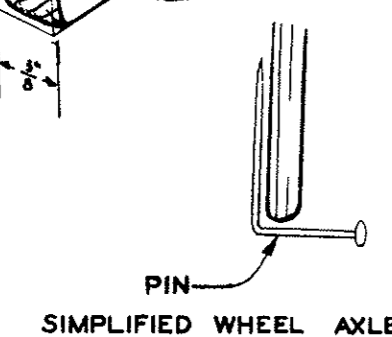
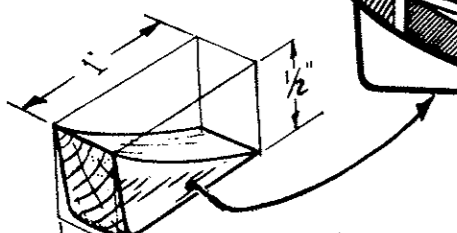
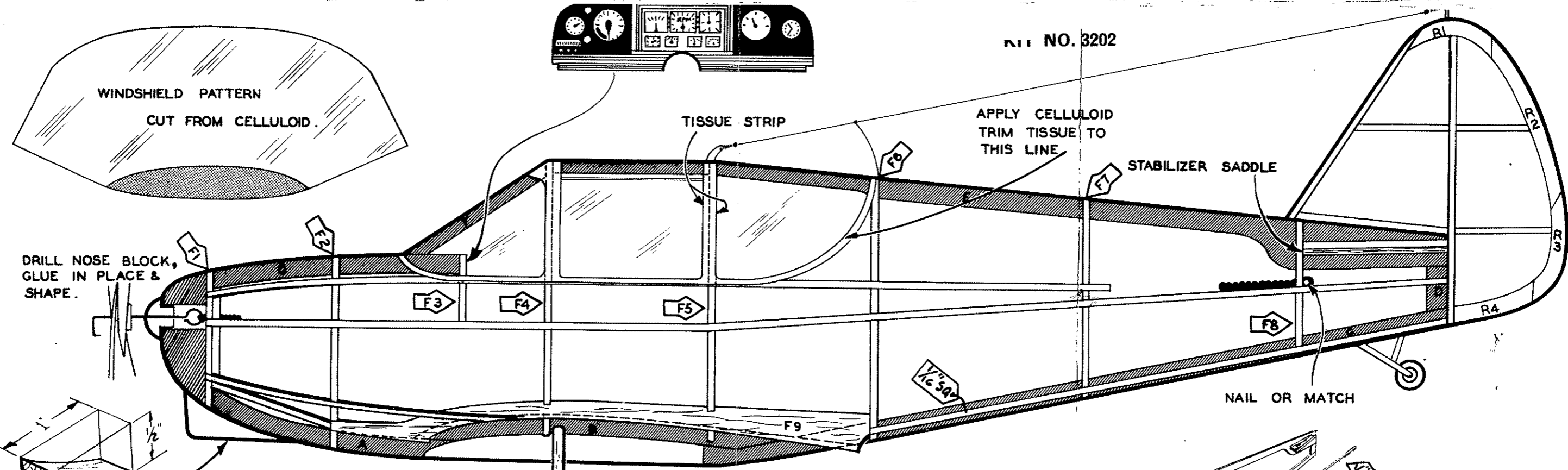

KIT NO. 3202

COMET MODEL HOBBYCRAFT

WHEEL WELL POSITION

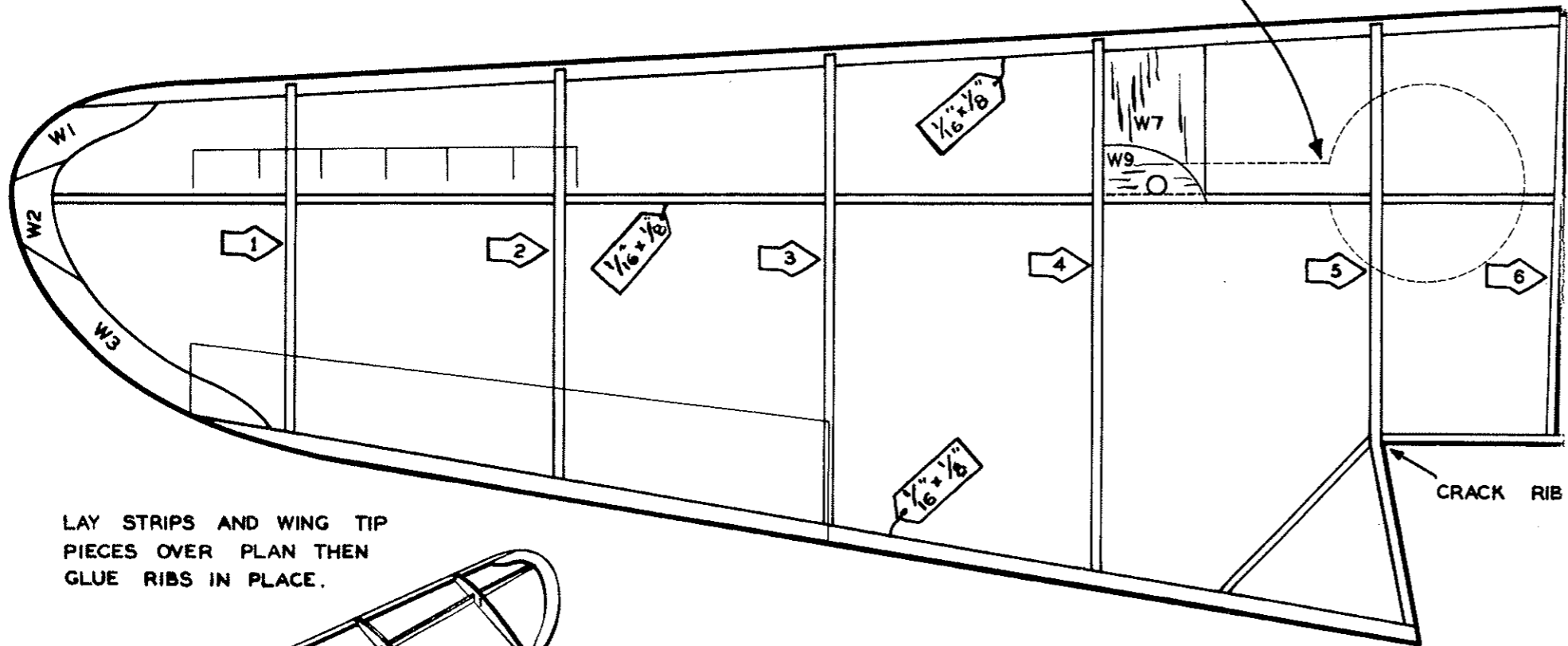

LAY STRIPS AND WING TIP PIECES OVER PLAN THEN GLUE RIBS IN PLACE.

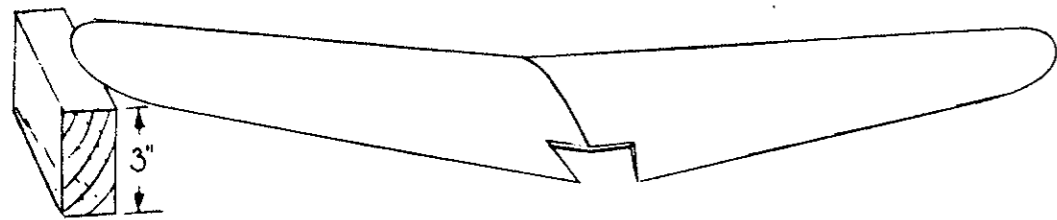
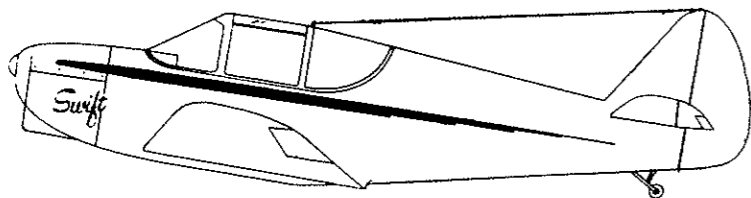
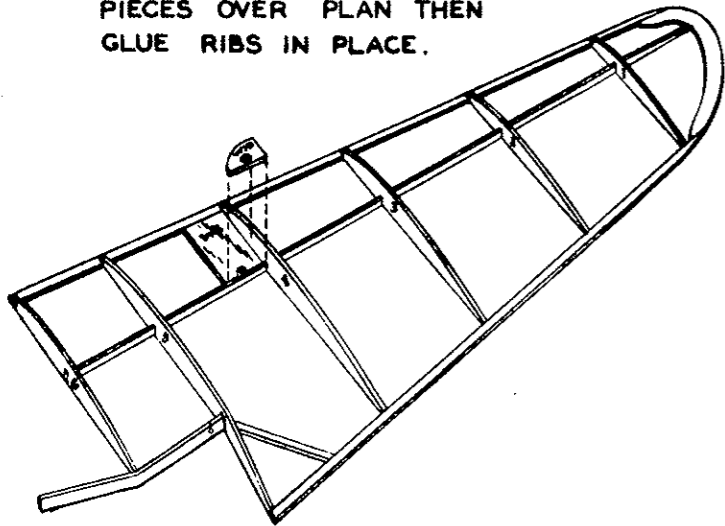

COMET

GLOBE

Swift

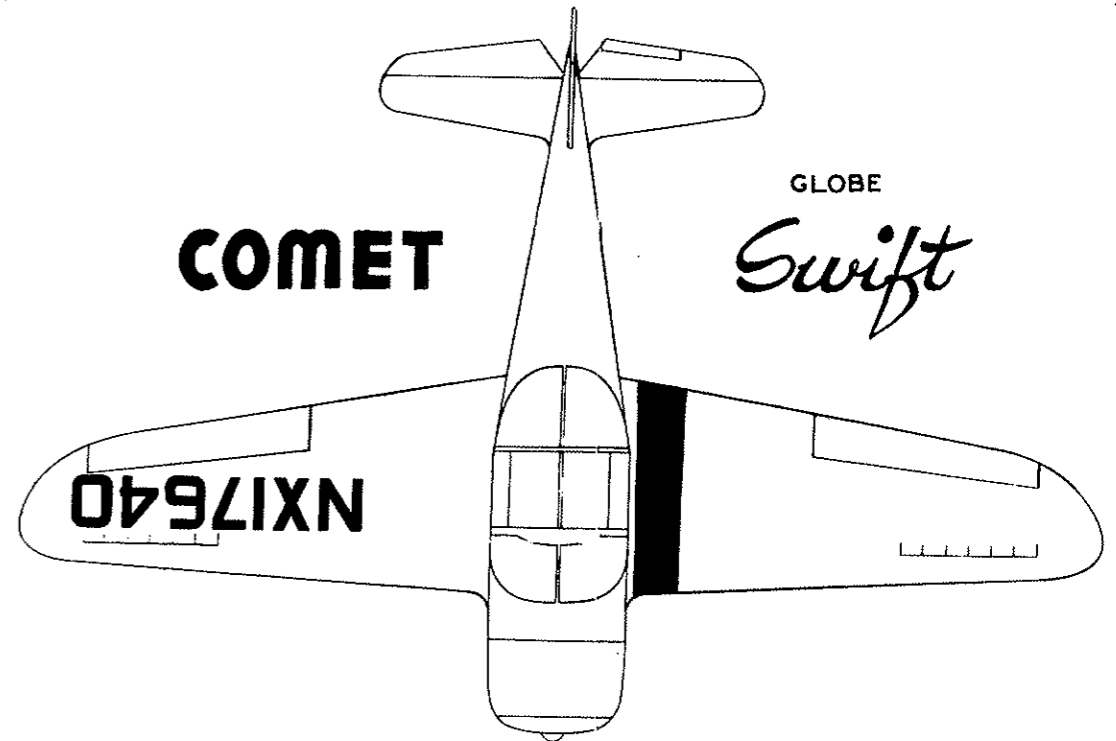

KIT NO. 3202

IN ASSEMBLY COVER PLAN WITH WAX PAPER.

WHEN COMPLETE CUT LICENSE NOS. FROM PLAN & DOPE

IN PLACI

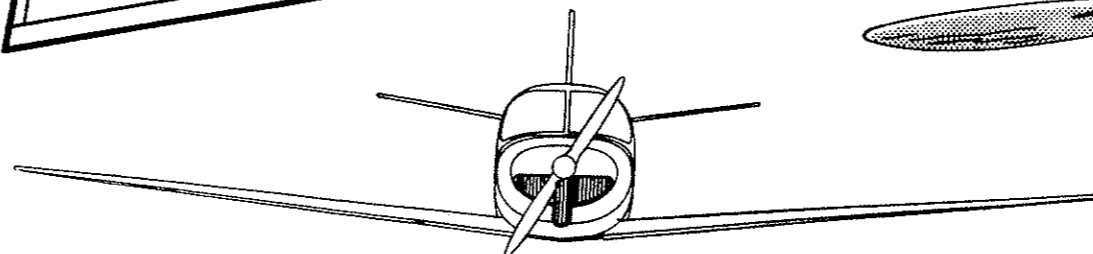
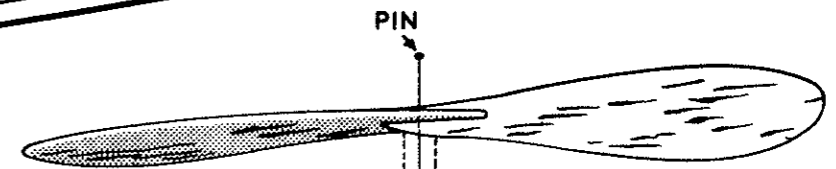
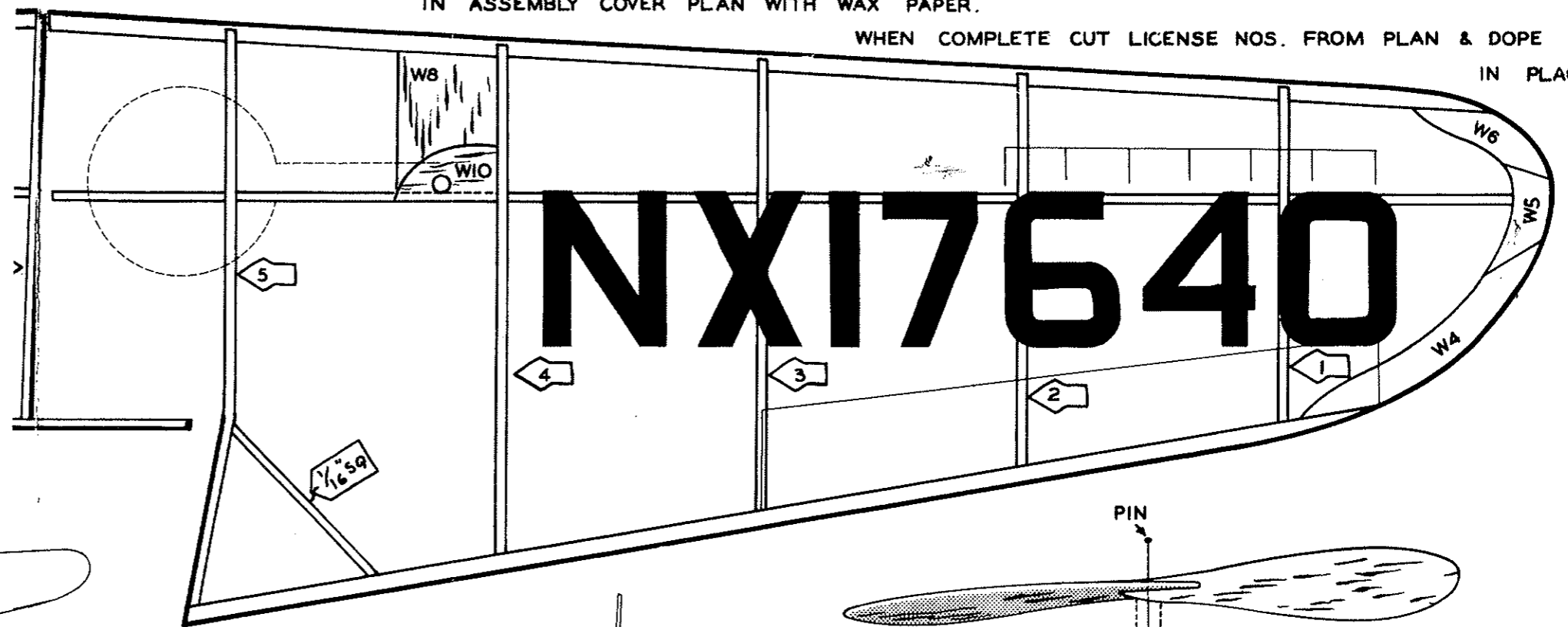

Suggested Stab

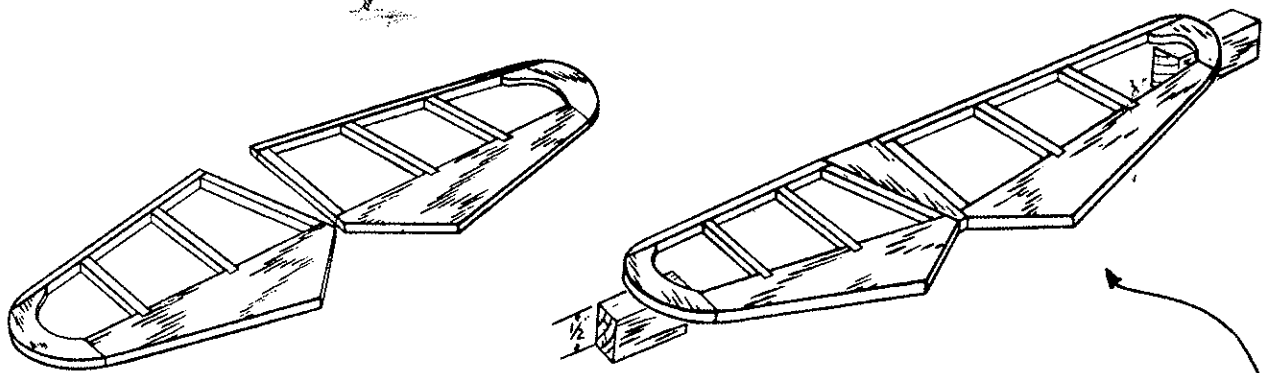
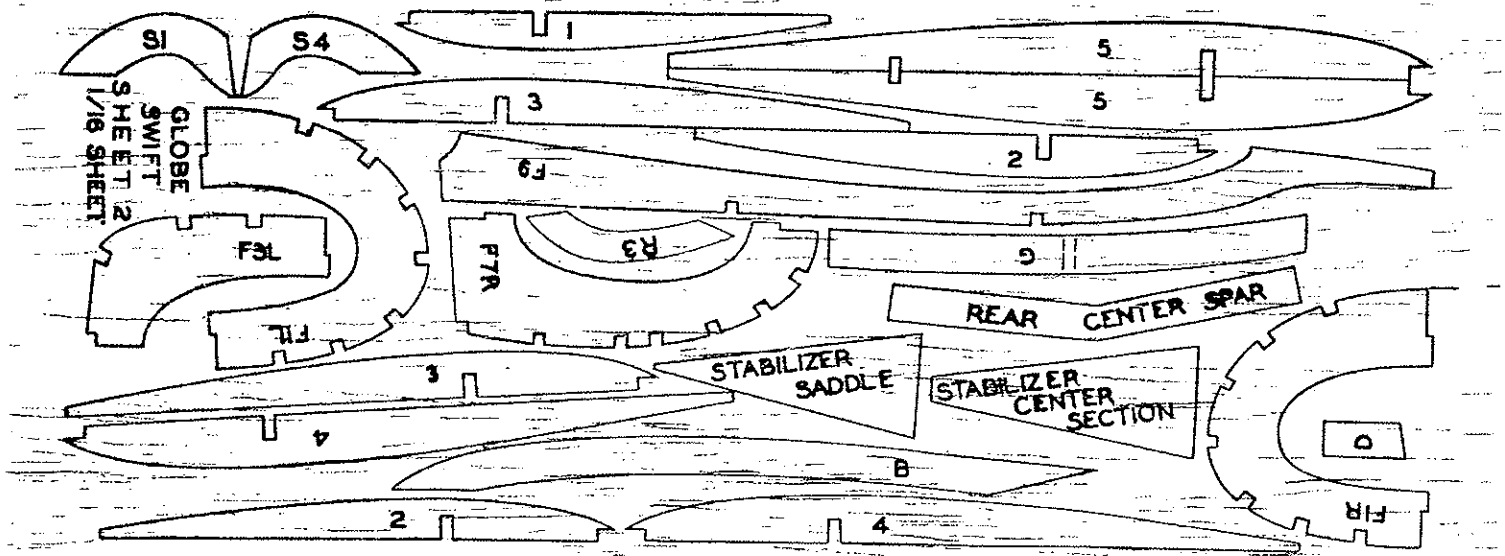
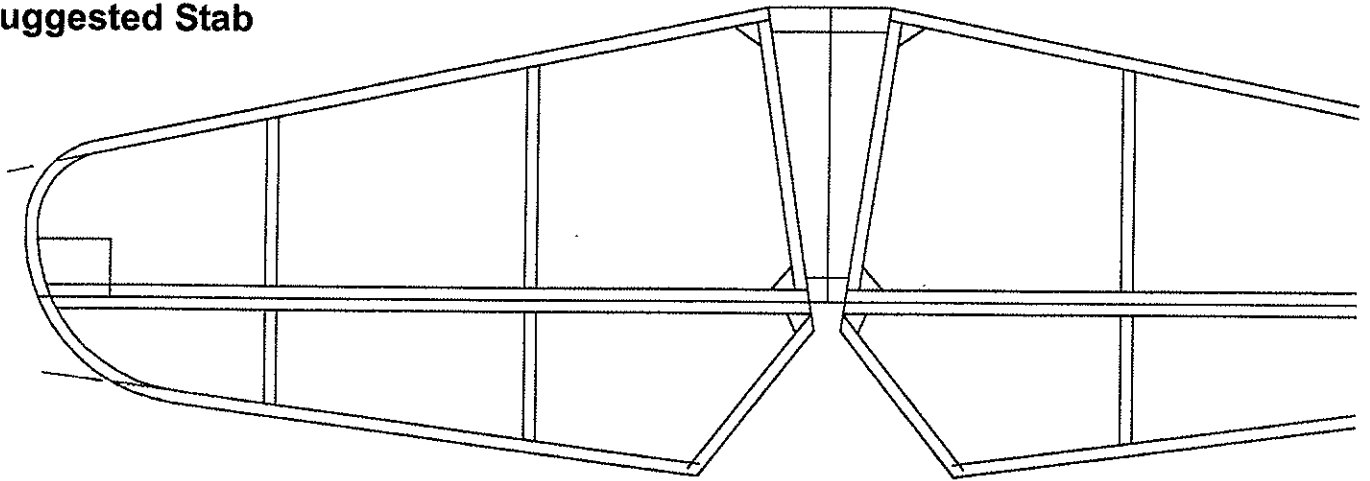

ASSEMBLE STABILIZER HALVES OVER PLAN THEN GLUE TO CENTER SECTION AS SHOWN

