

The elevator and rudder structure shown here is light and efficient. However, for simplicity $\frac{1}{32}$ " or $\frac{1}{16}$ " sheetwood cut to outline may be substituted.

Copyright 1946

All rights reserved.

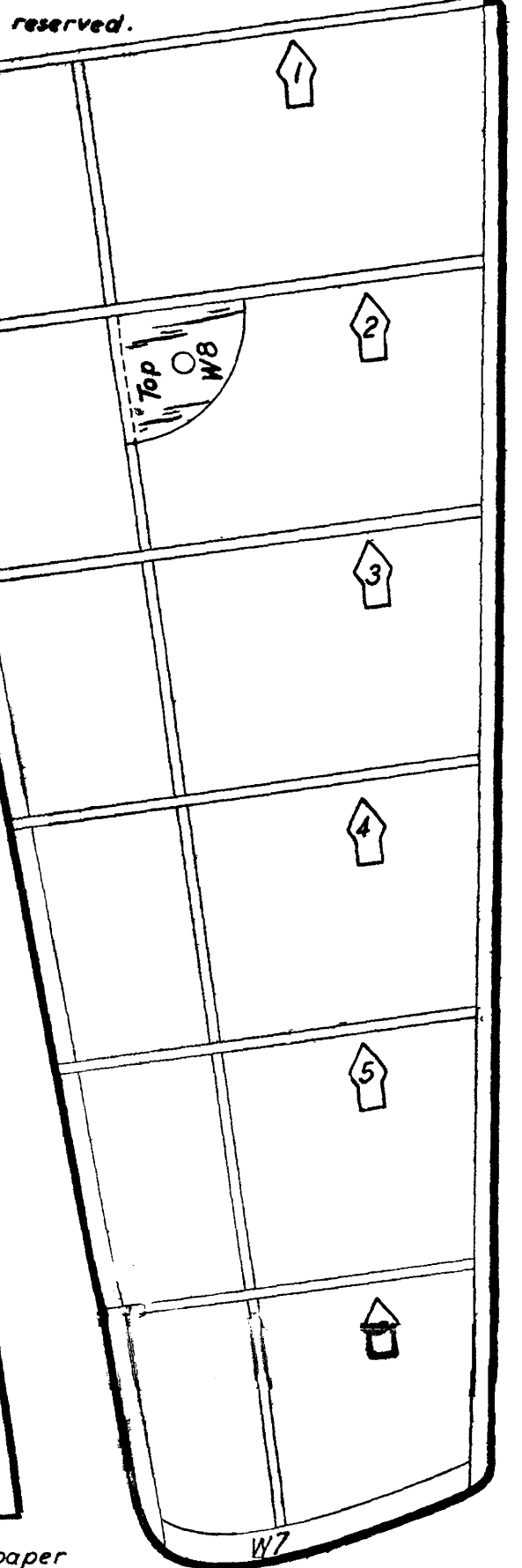
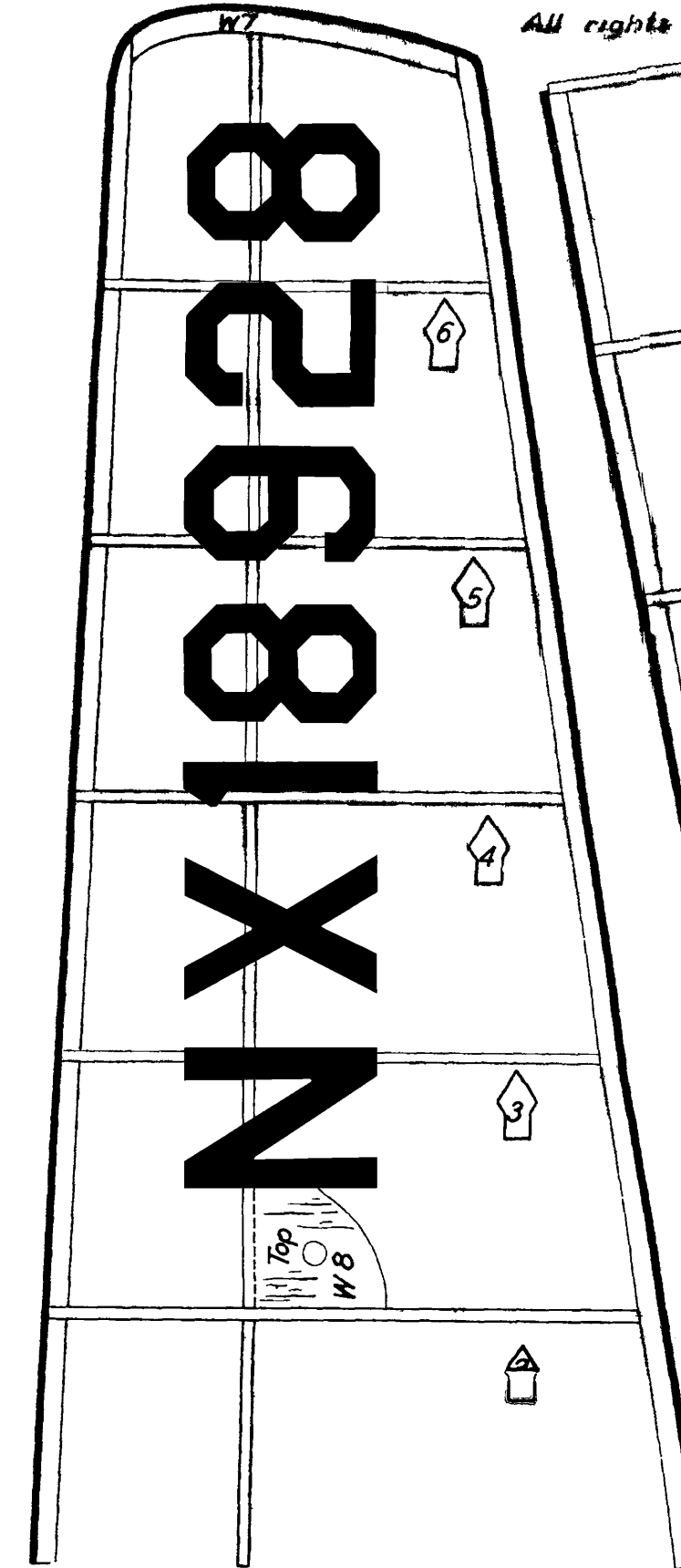
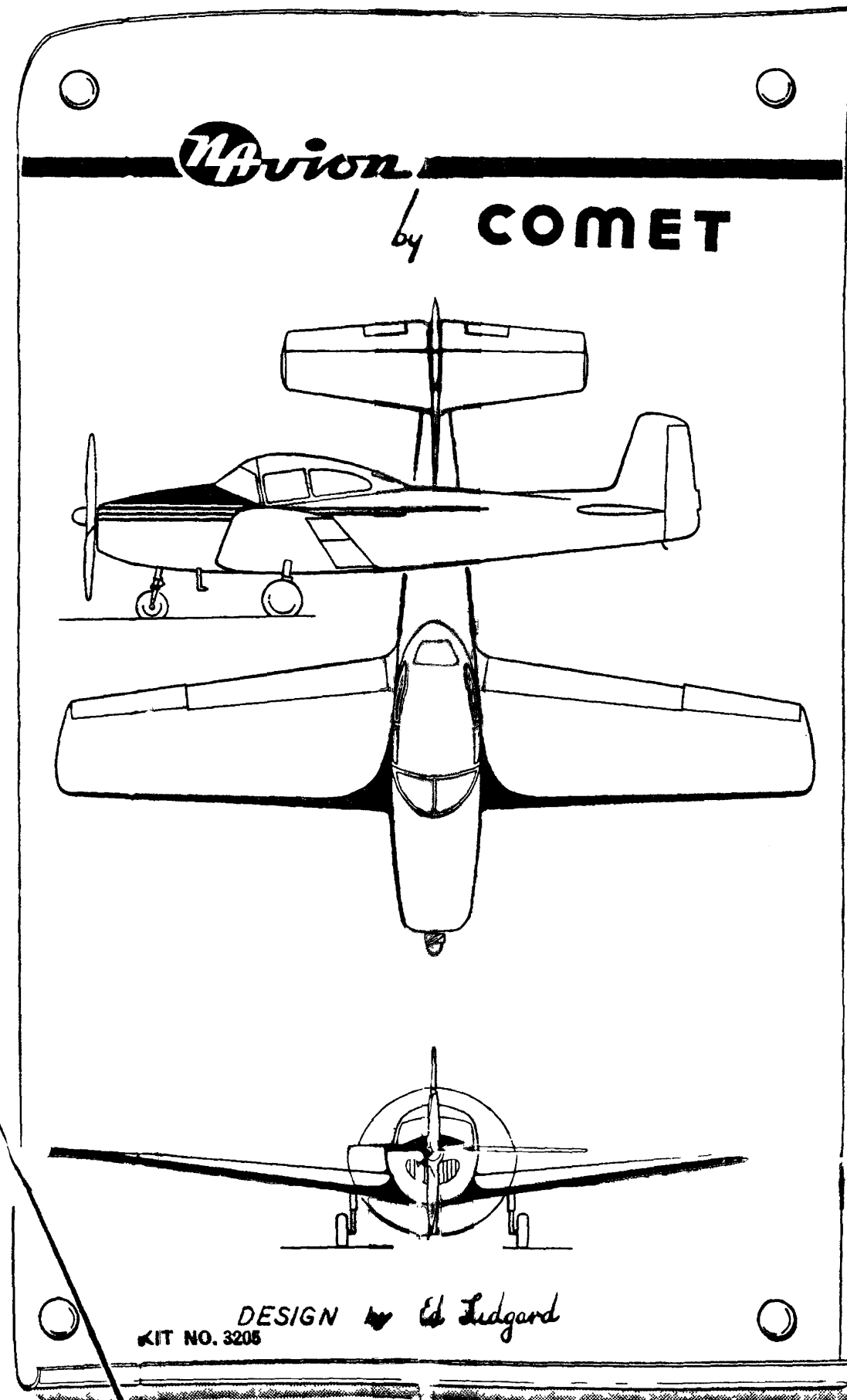
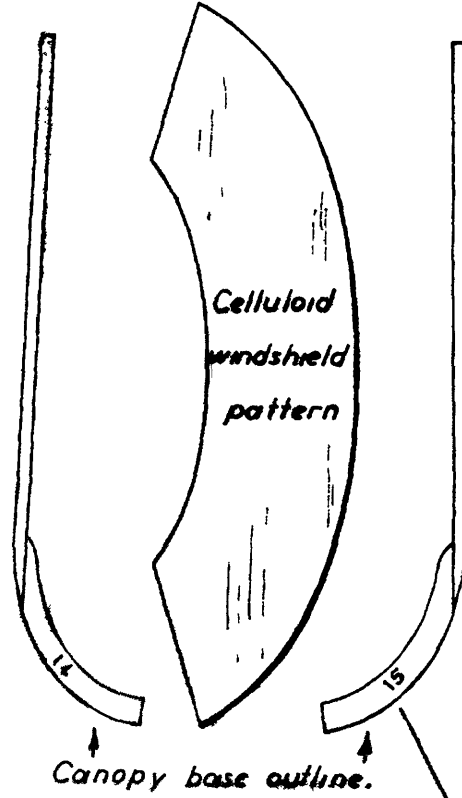
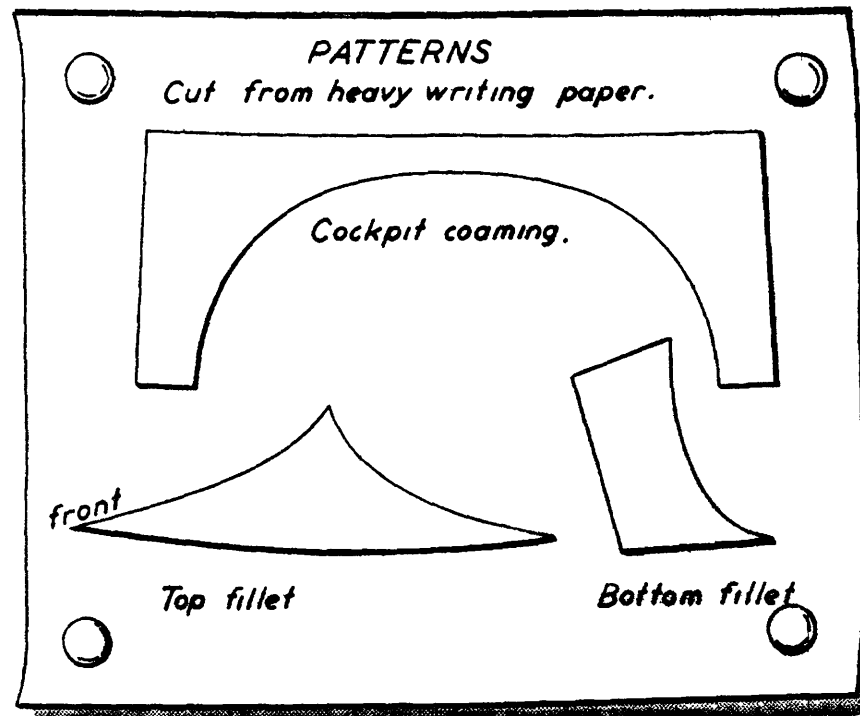
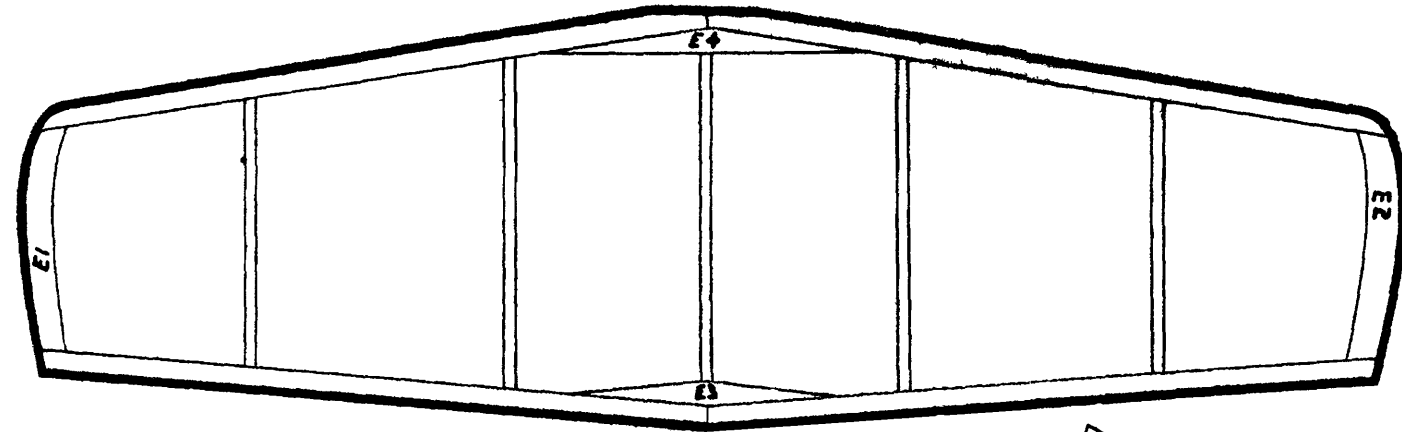

Cover portions of plan worked over with waxed paper

NX18928

Cut out and dope to underside of left wing.

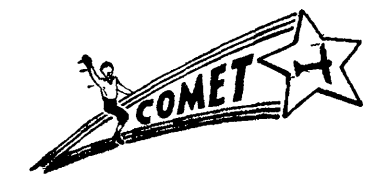
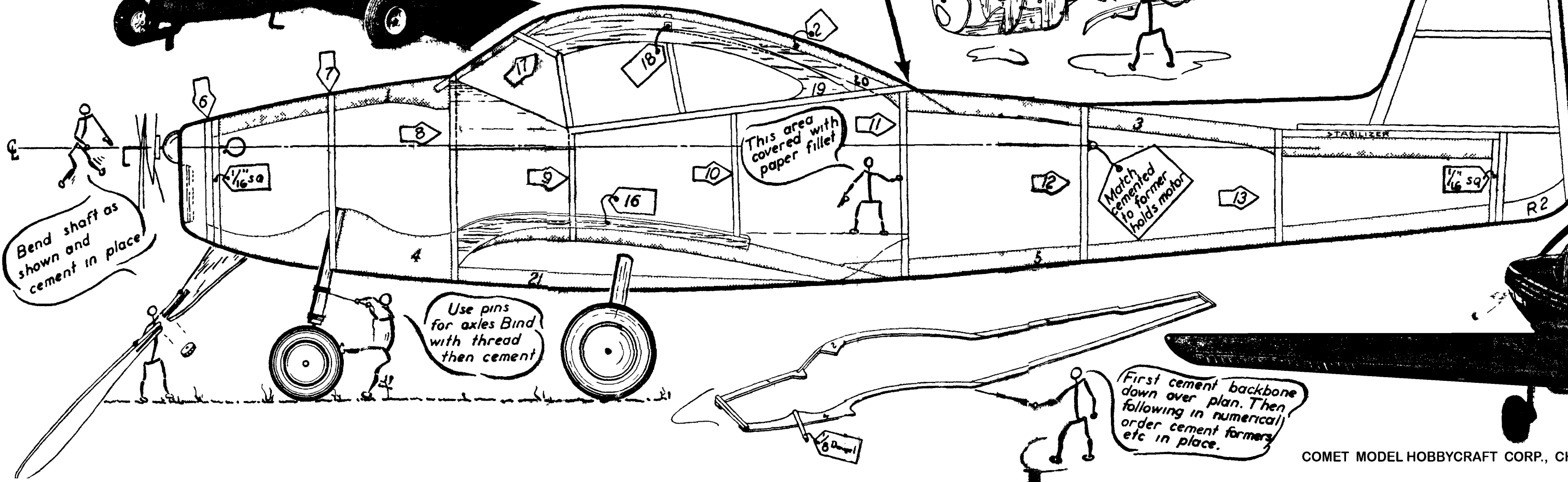
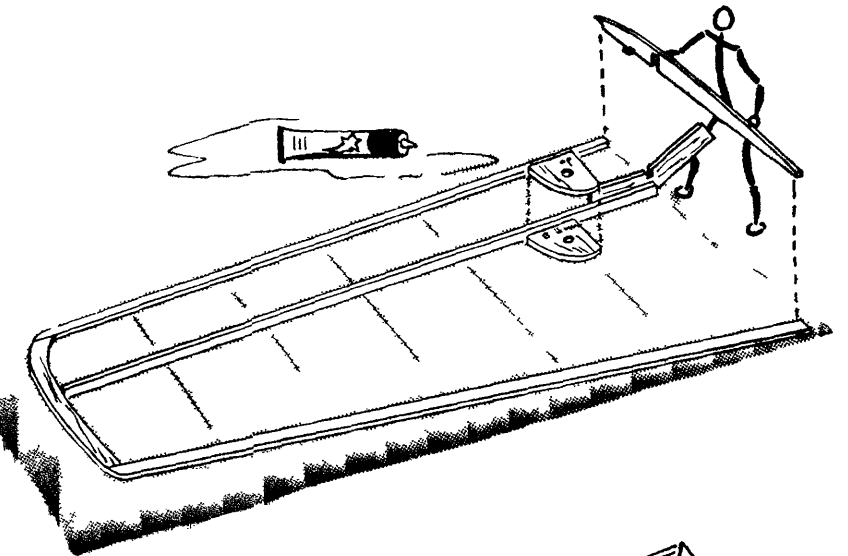
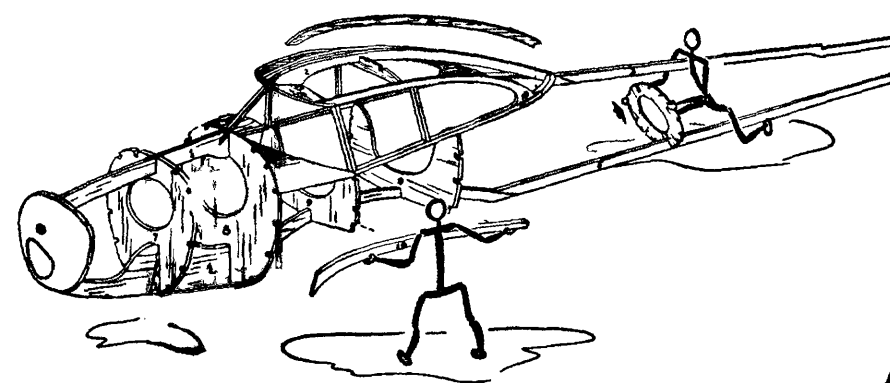
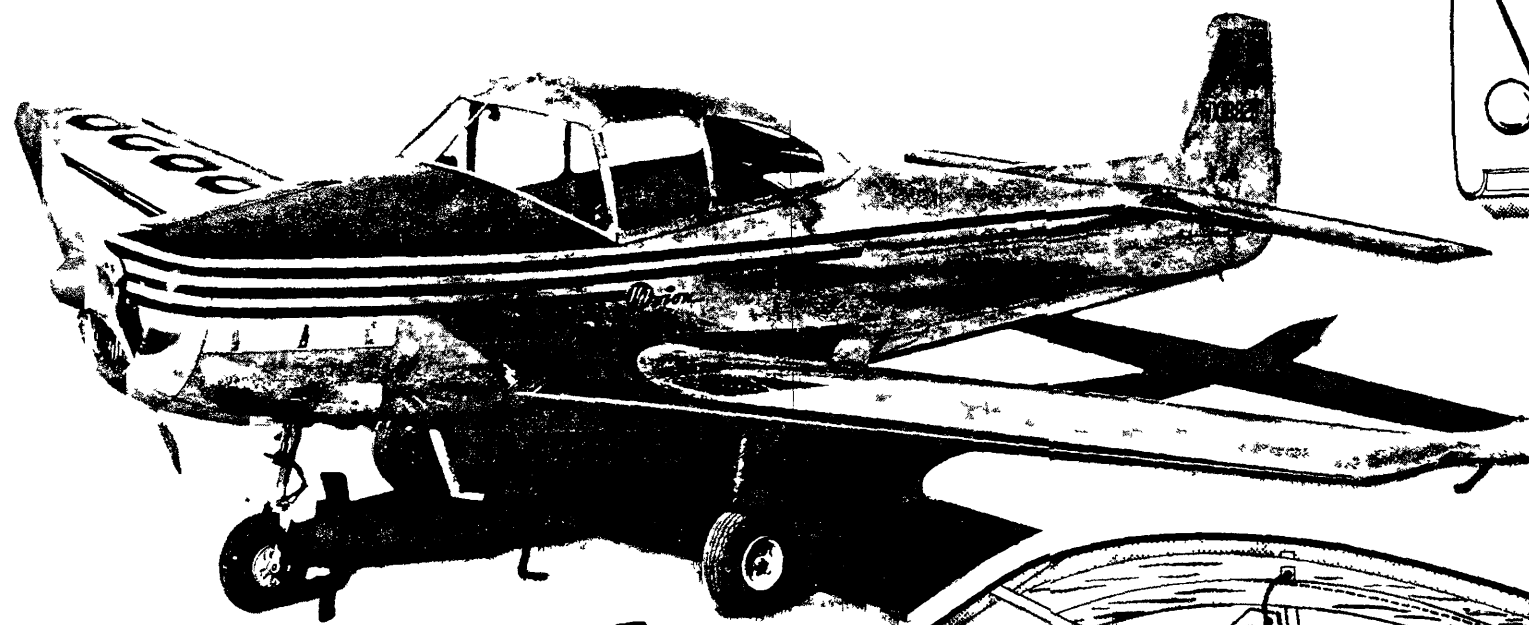

COMET MODEL HOBBY CRAFT CORP., CHICAGO, ILL.

