

44

CUT NUMERALS ON OUTER EDGE OF BLACK TRIM AND ATTACH TO MODEL.

A FLAT PEBBLE, ROUGHLY ABOUT 5/8" DIA. & 5/16" THICK SHOULD BE CEMENTED TO FORMER FOR NECESSARY BALANCE.

"JUPITER"

DESIGNED & DRAWN BY Vito M. Marofalo

KIT NO. E 14

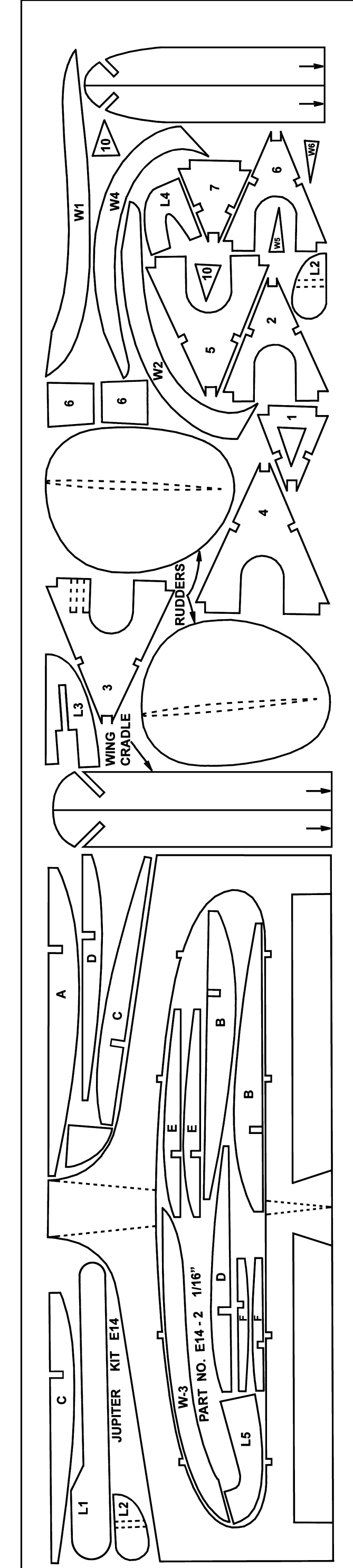
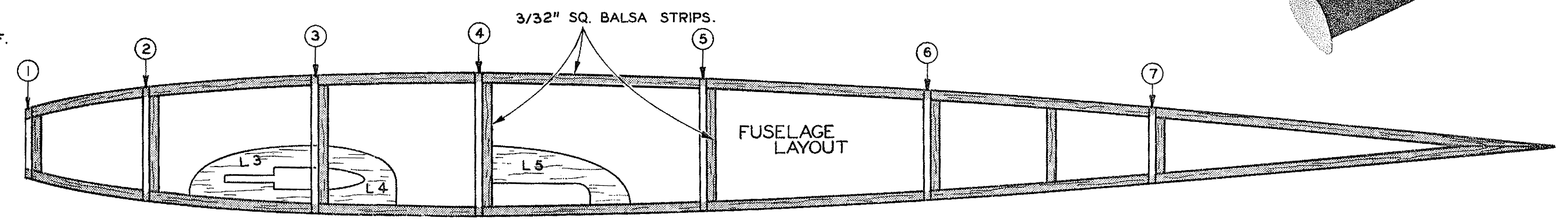
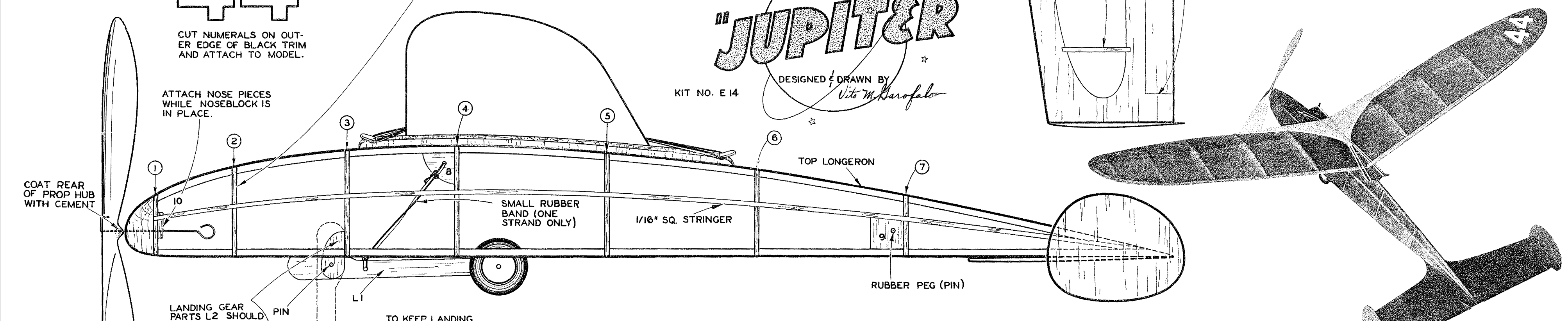

- 1 BUILD BOTTOM OVER LAYOUT
- 2 CEMENT FORMERS IN PLACE, (SEE SKETCHES ABOVE)
- 3 THEN TOP LONGERON
- 4 AND NEXT THE STRINGERS.