

MANY STRINGERS NOT  
SHOWN ON FUSELAGE  
PLAN TO REVEAL 1/16"  
SHEET BALSA KEELS

FUSELAGE BULKHEADS  
A-H 1/16" SHEET BALSA.  
2 EACH REQUIRED

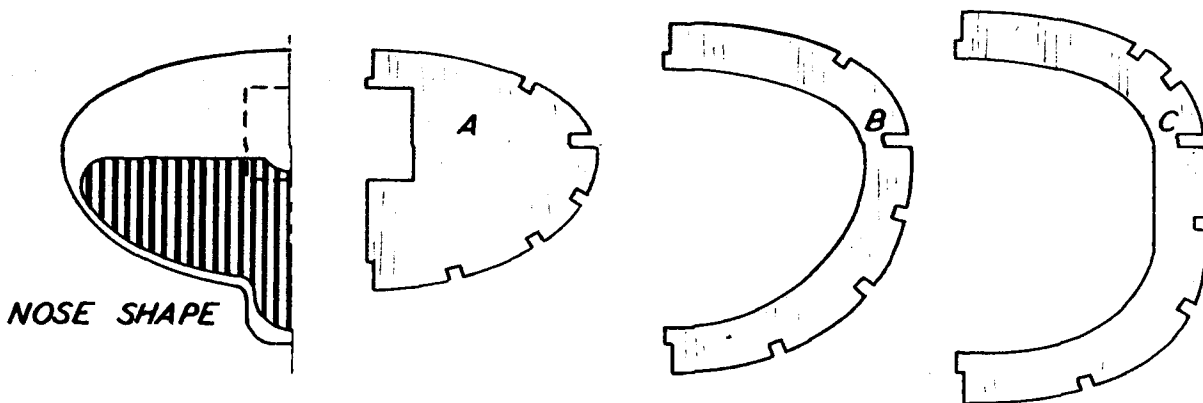

NOSE SHAPE

NOSE BLOCK IS LAMINATED  
SHEET. SHADED AREAS OF  
NOSE "FILLED-IN"

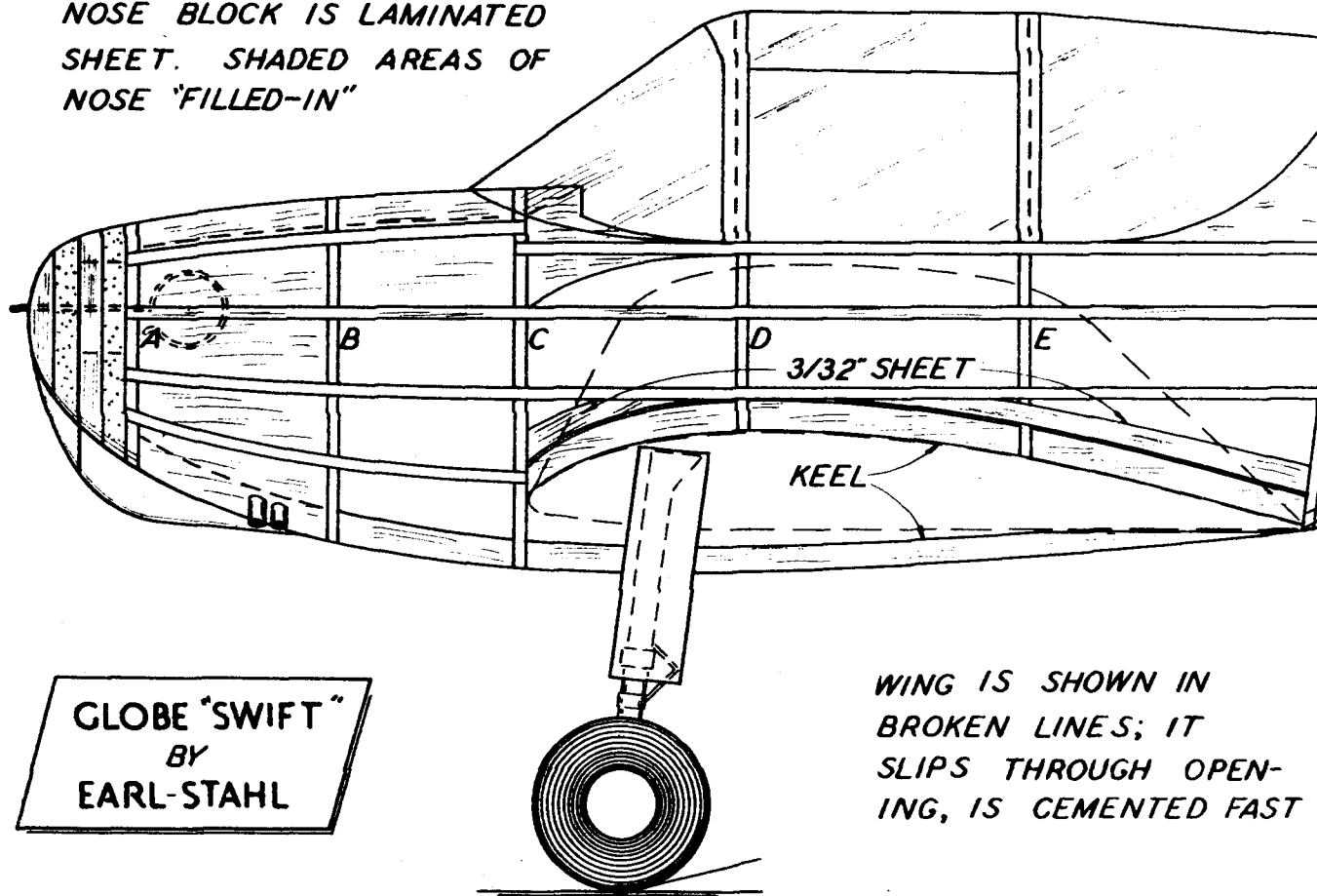

WING IS SHOWN IN  
BROKEN LINES; IT  
SLIPS THROUGH OPEN-  
ING, IS CEMENTED FAST

GLOBE "SWIFT"  
BY  
EARL-STAHLE

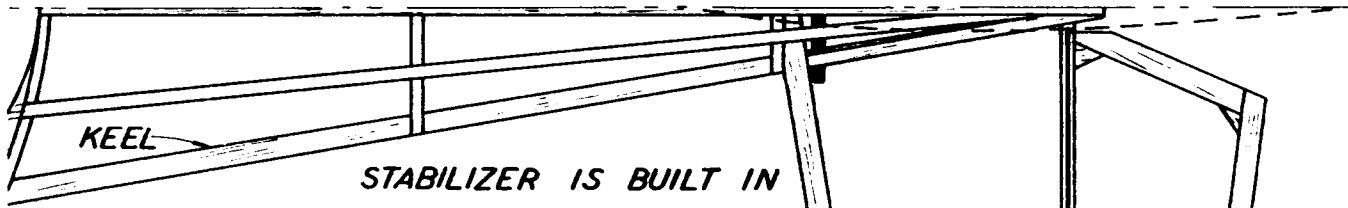

STABILIZER IS BUILT IN ONE PIECE, THEN CRACK & RAISE TIPS 7/16"

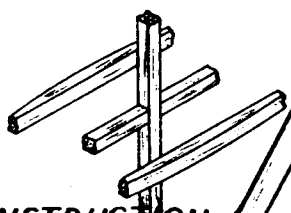
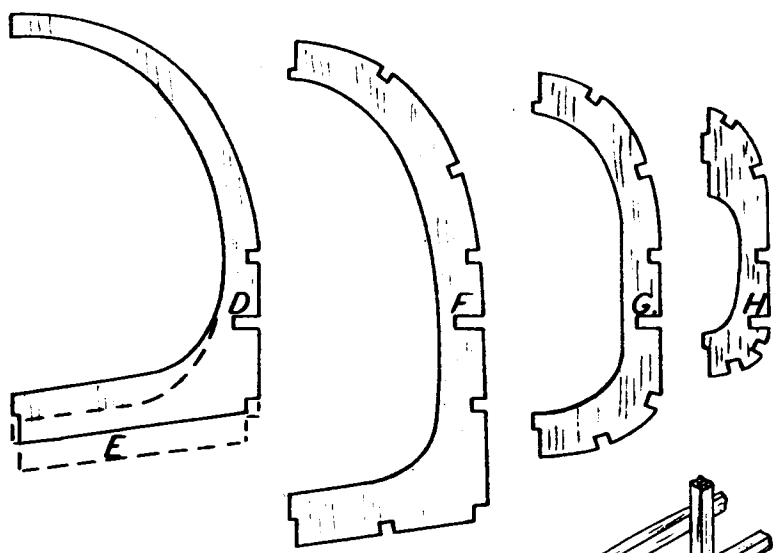

RIB CONSTRUCTION

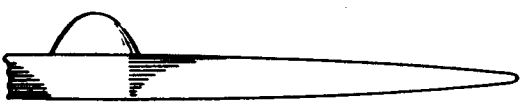
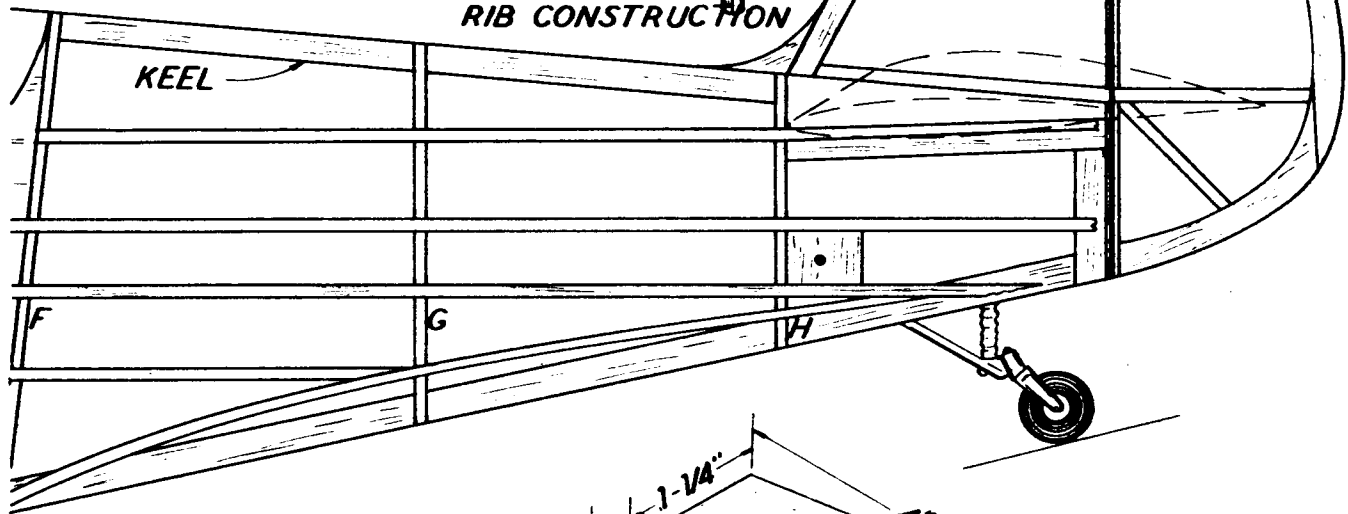

SCALE PROPELLER

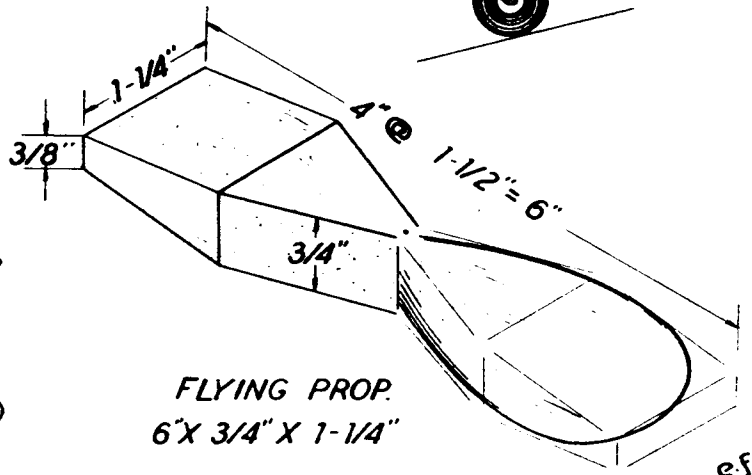

FLYING PROP.  
6" X 3/4" X 1-1/4"

LEADING EDGE & SPAR CUT  
FROM SHEET; TIP 3/32" SHEET

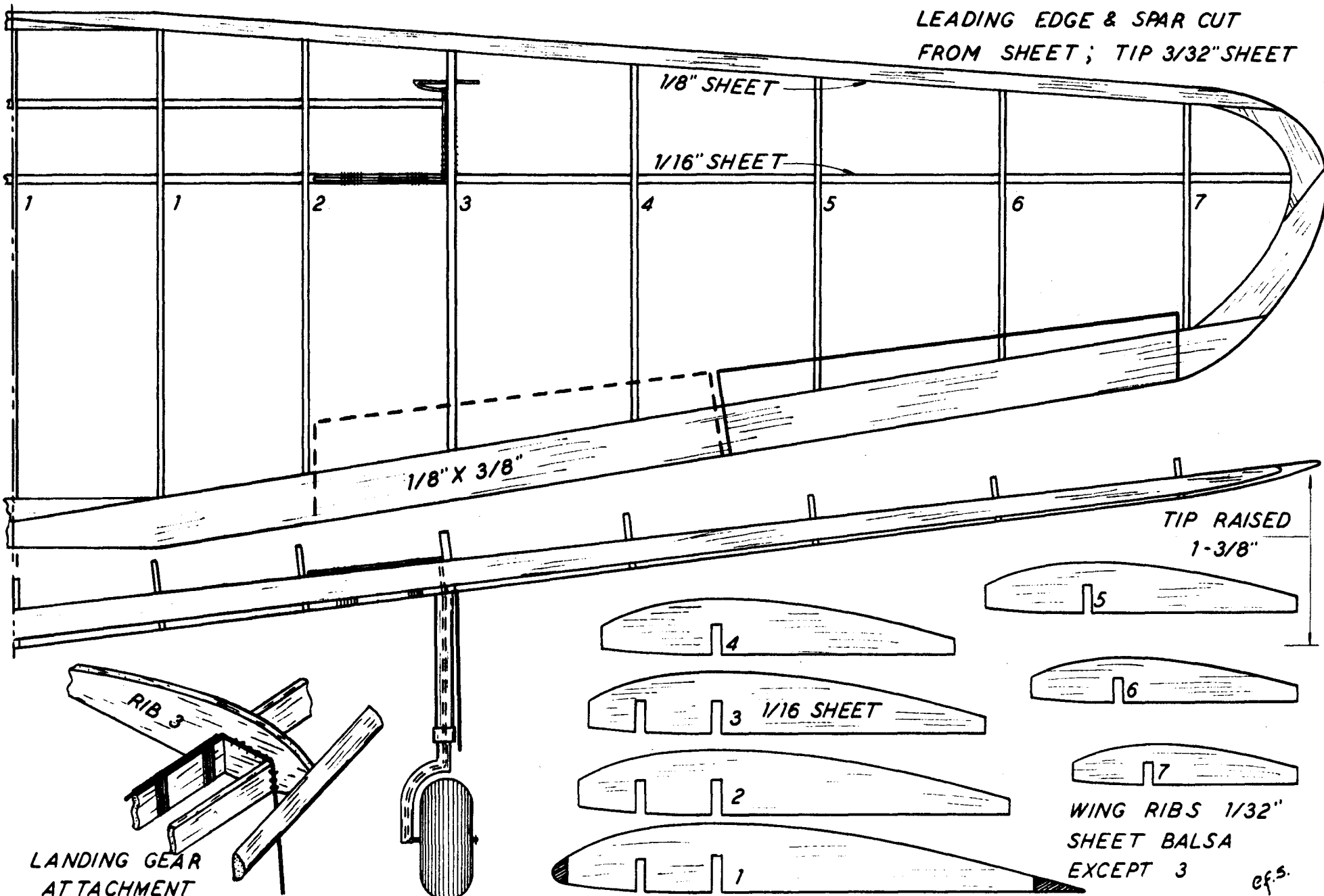

LANDING GEAR  
ATTACHMENT

WING RIBS 1/32"  
SHEET BALSA  
EXCEPT 3

cf. 5.