

This free plan courtesy of the Rees Family

WING FRAME WEIGHT: 6.5 GMS.

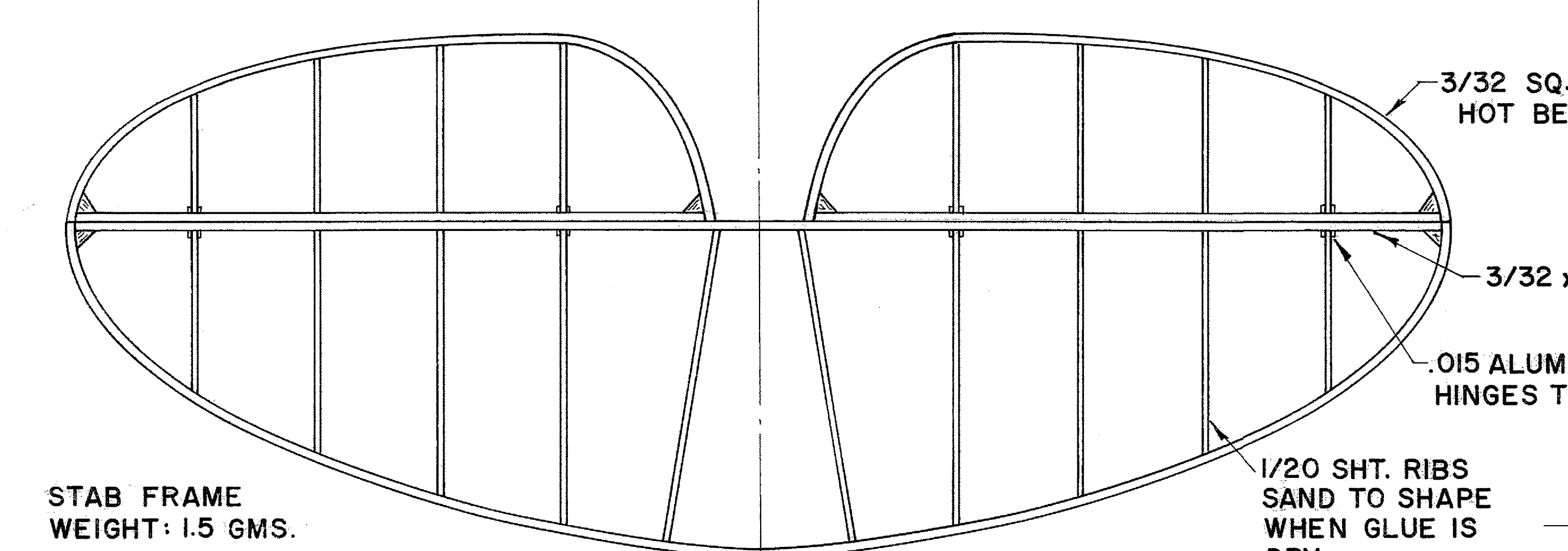

STAB FRAME WEIGHT: 1.5 GMS.

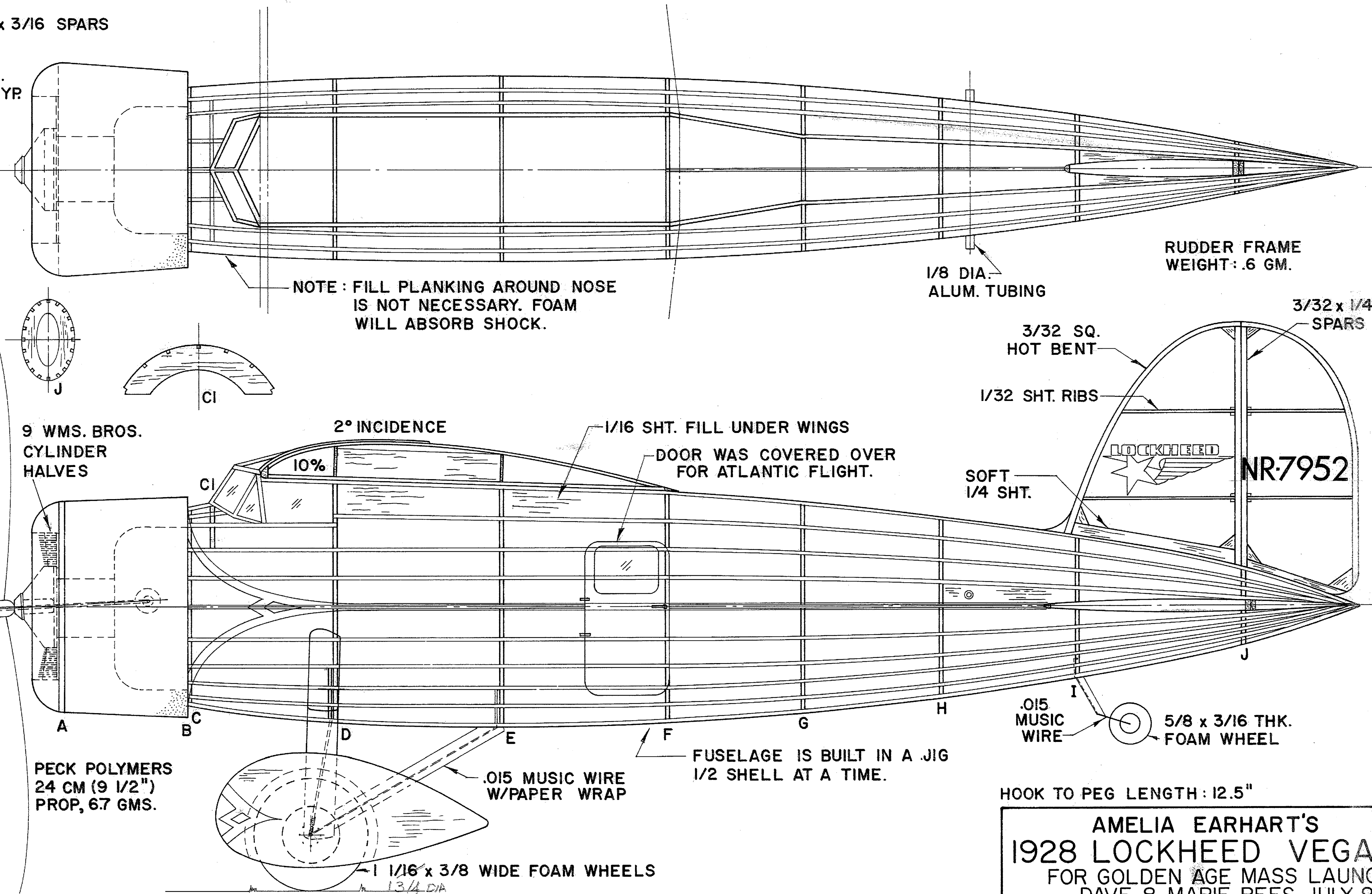
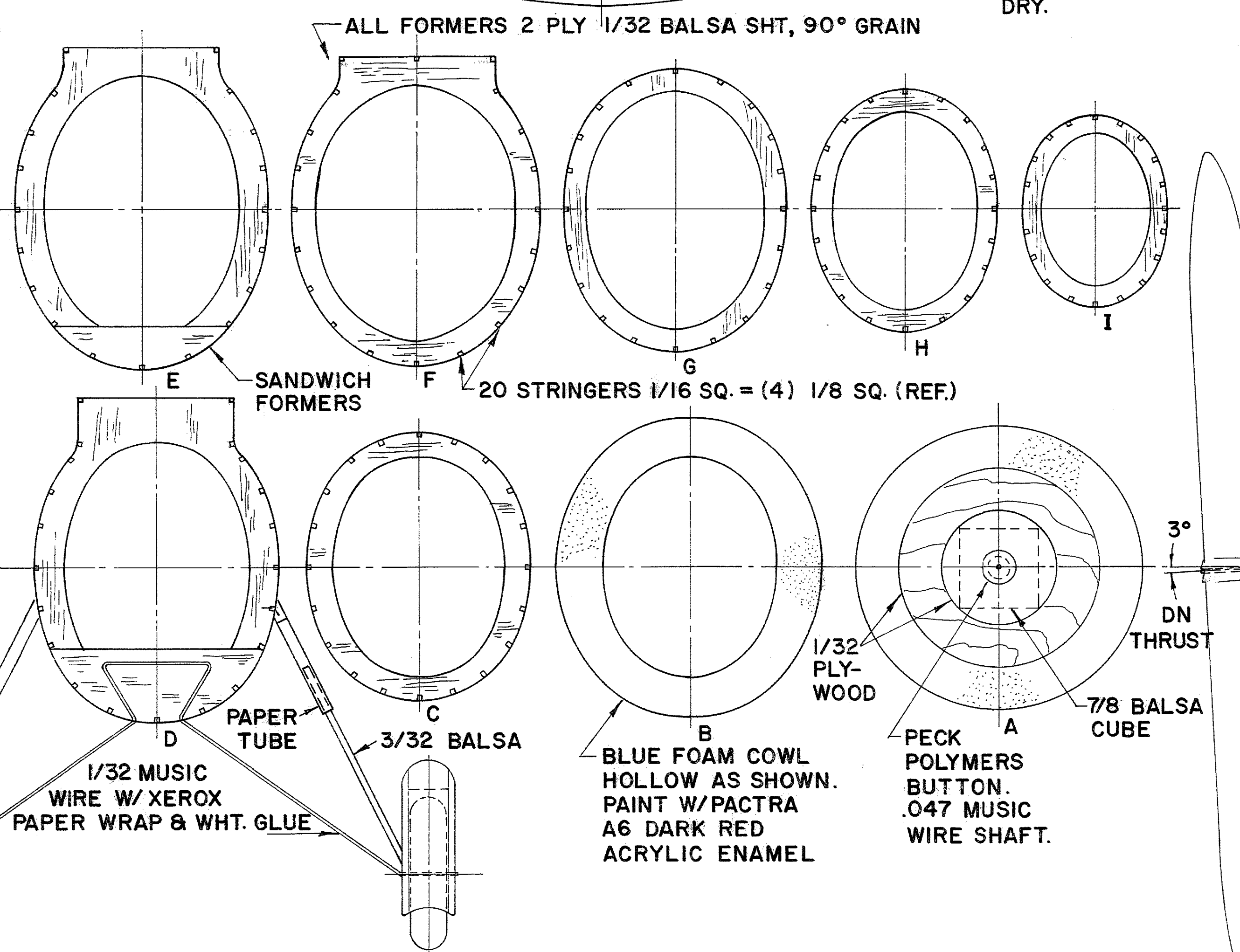

-REFERENCE DATA-

PHOTOS & 3 VIEWS FROM "REVOLUTION IN THE SKY" BY R.S. ALLEN.  
COVER AIRFRAME WITH WHITE MICRO-X TISSUE, ALCOHOL SHRUNK.  
AIRBRUSH 1 COAT AEROGLOSS FOKKER RED 54-1 LACED WITH T.C.P.  
GOLD STICKY-BACKED MONOCOAT STRIPING. BLACK NUMBERS.  
PROTOTYPE WEIGHT: 56 GMS, WING AREA: 147 SQ. INS, SPAN: 30.5  
POWER: 2 LOOPS FAI TAN 2, 3/16 x .050 x 36" LONG, 1800 WINDS.

HOOK TO PEG LENGTH: 12.5"

AMELIA EARHART'S  
1928 LOCKHEED VEGA  
FOR GOLDEN AGE MASS LAUNCH  
DAVE & MARIE REES JULY 92