

-REFERENCE DATA-

- *AIR INTERNATIONAL VOL 13 NOS. 1, 2 & 3 JUL, AUG, SEP 1977 3-VIEWS, CUTAWAY DWG. PLUS B & W PICTURES. FIGHTERS 1914-19 BY KEN MUNSON PG. 45 COLOR 2 VIEW.
- *ENTIRE AIRFRAME COVERED W/WHITE MICRO-X JAP TISSUE. TOP SURFACES SPRAYED 1 COAT AERO GLOSS FLAT OLIVE DRAB 34-1. UNDERSIDES 1 COAT OF 50/50 MIX TAYLORCRAFT CREAM 64-1 & SWIFTWHITE 56-1.
- *WING AREA: 291 SQIN. SPAN 30"
- *PROTOTYPE WEIGHT: 56.5 GM. .194 GM/SQIN.
- *HOOK TO PEG LENGTH: 13 5/8"
- *POWER: .200 x .045 x .43", 2 LOOPS FAI TAN 2, 24.4 GM. 1600 WINDS.

-WING WEIGHTS-
 FRAME: 5 GM
 COVERED: 7.5 GM

This free plan courtesy of the Rees Family

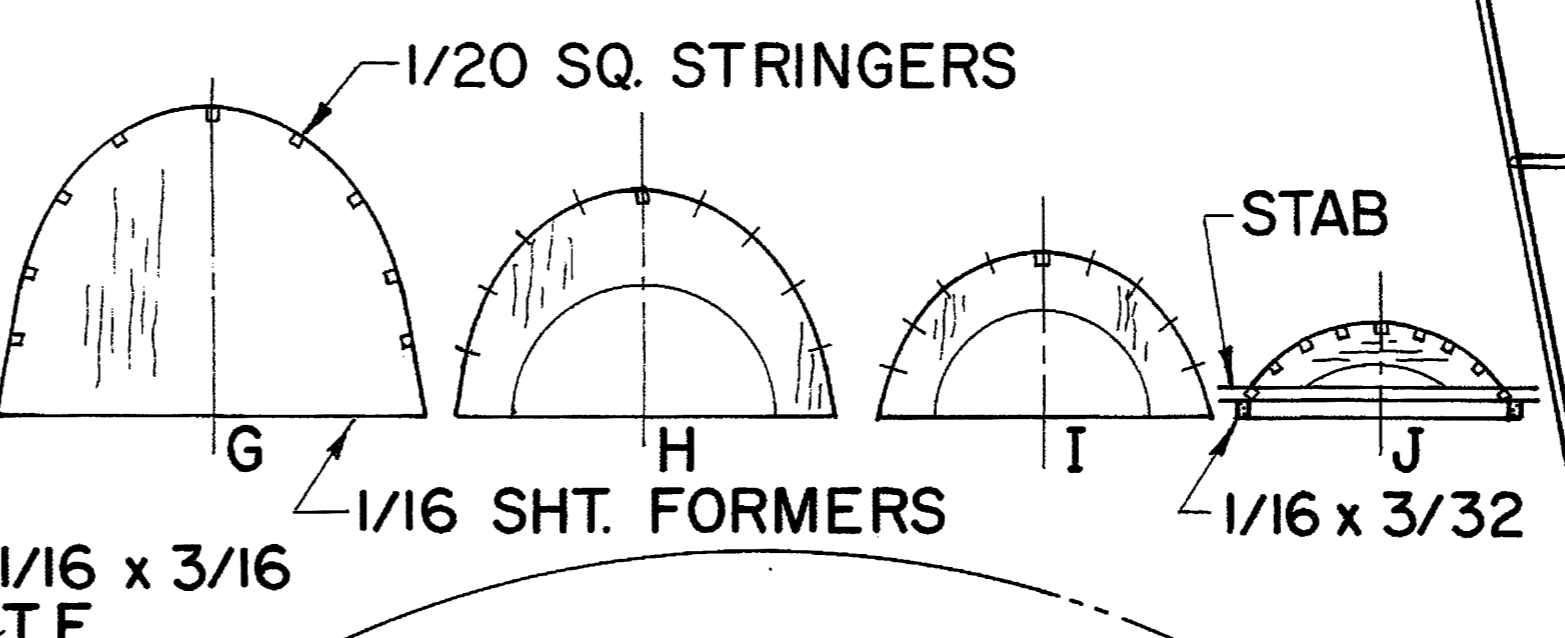
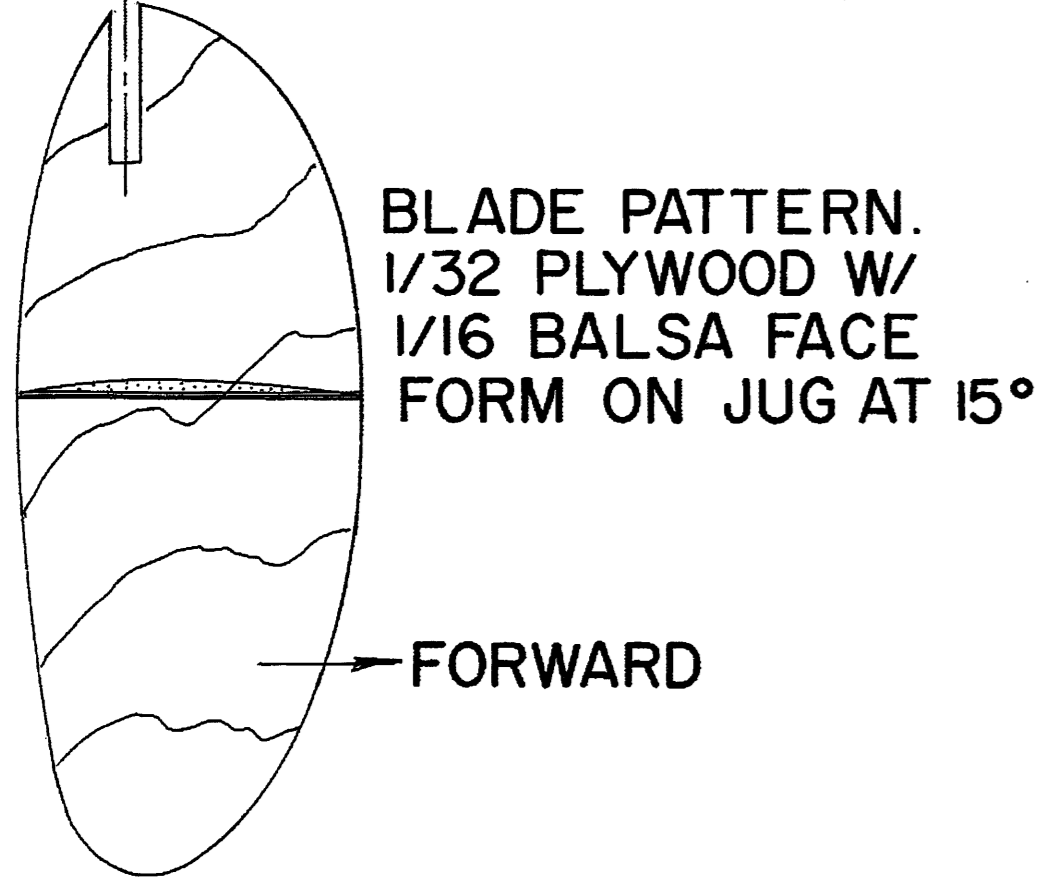
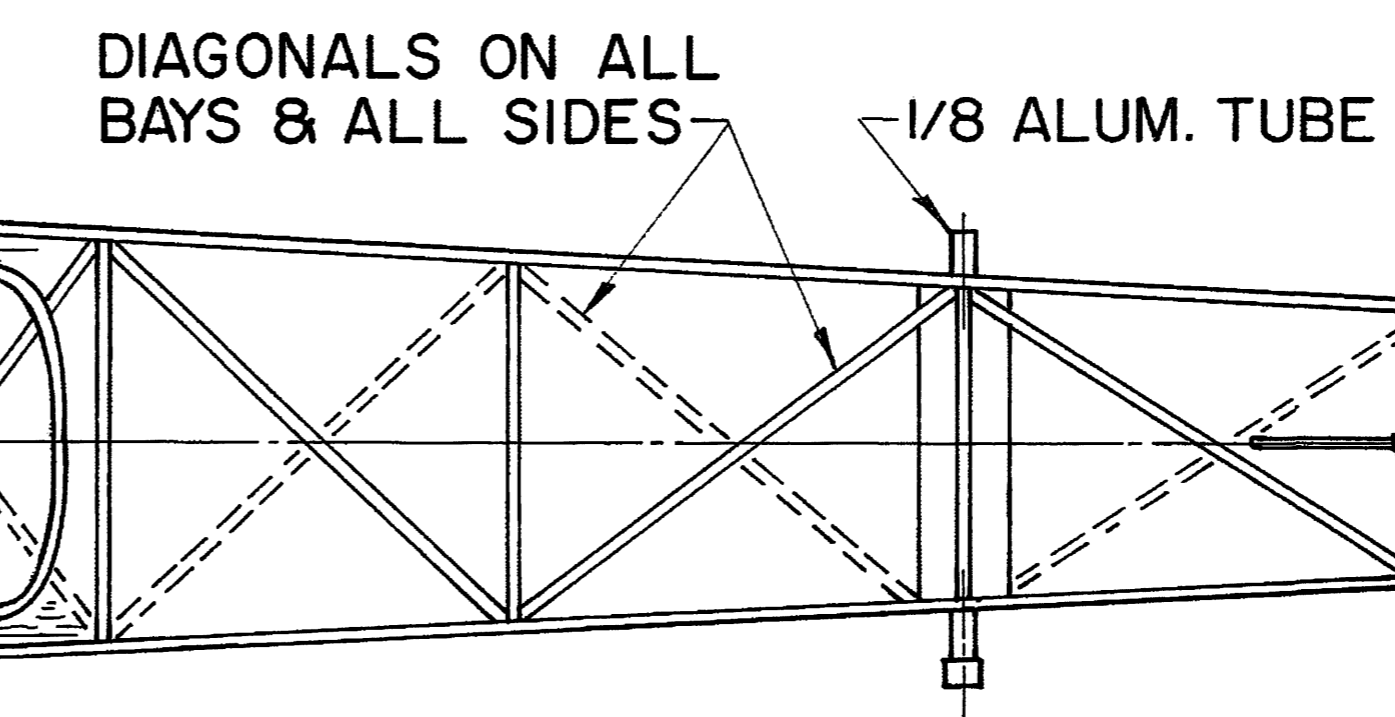
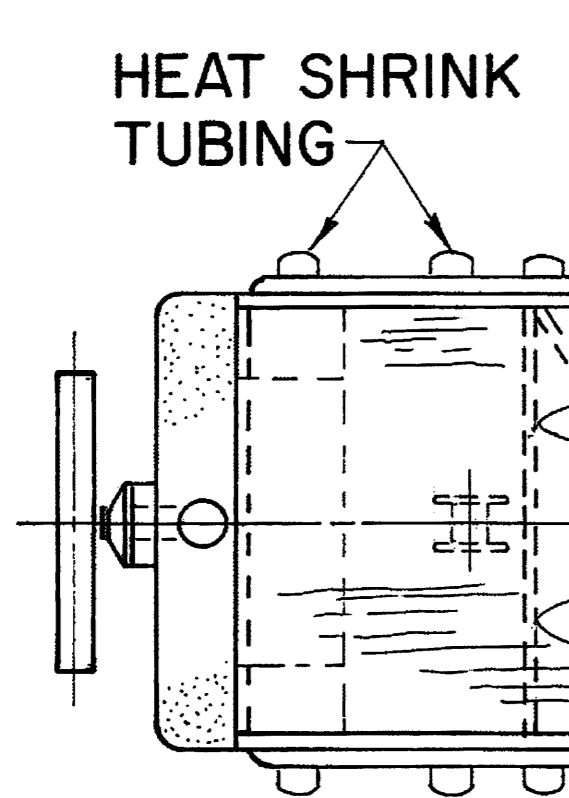
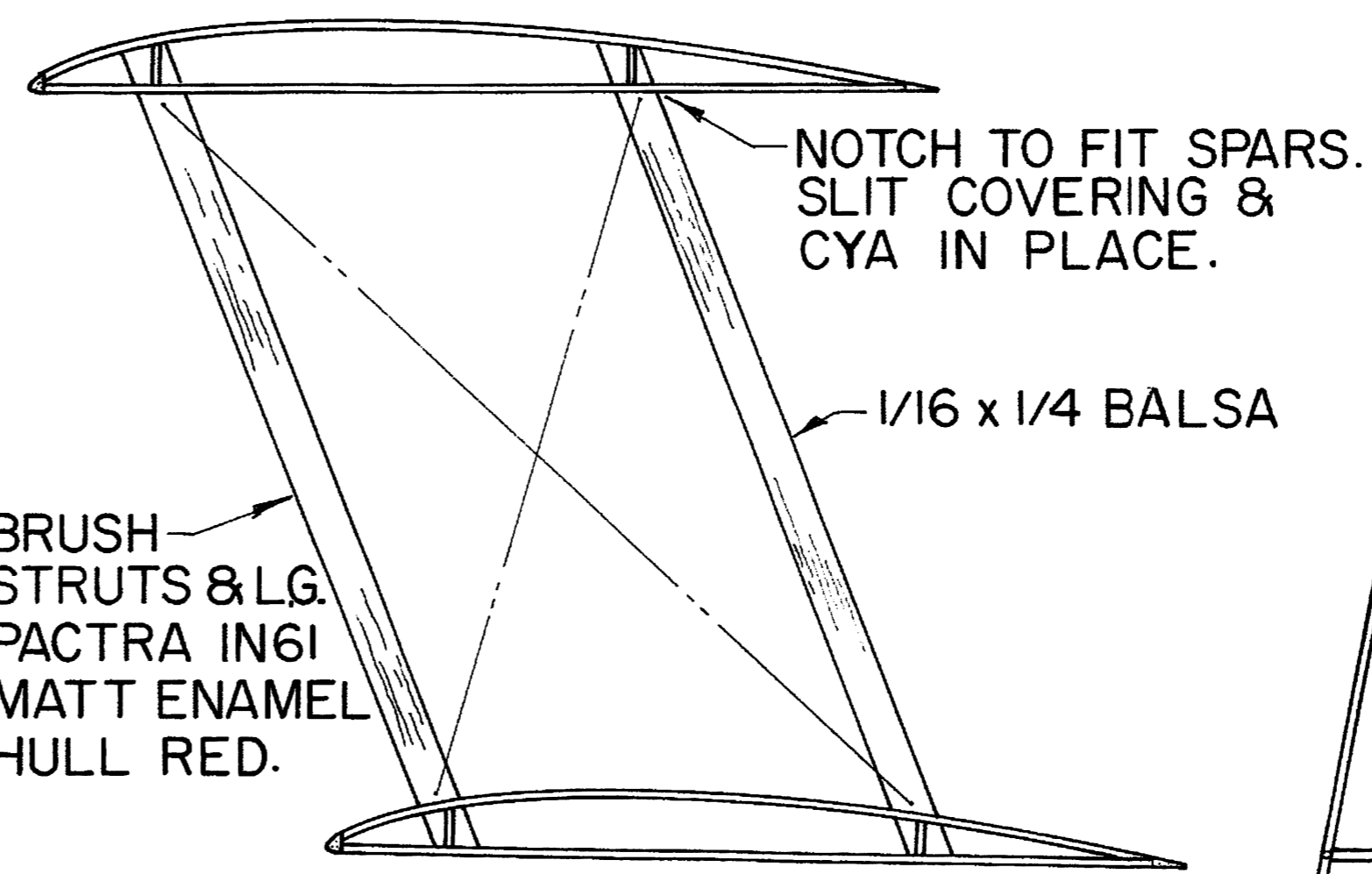
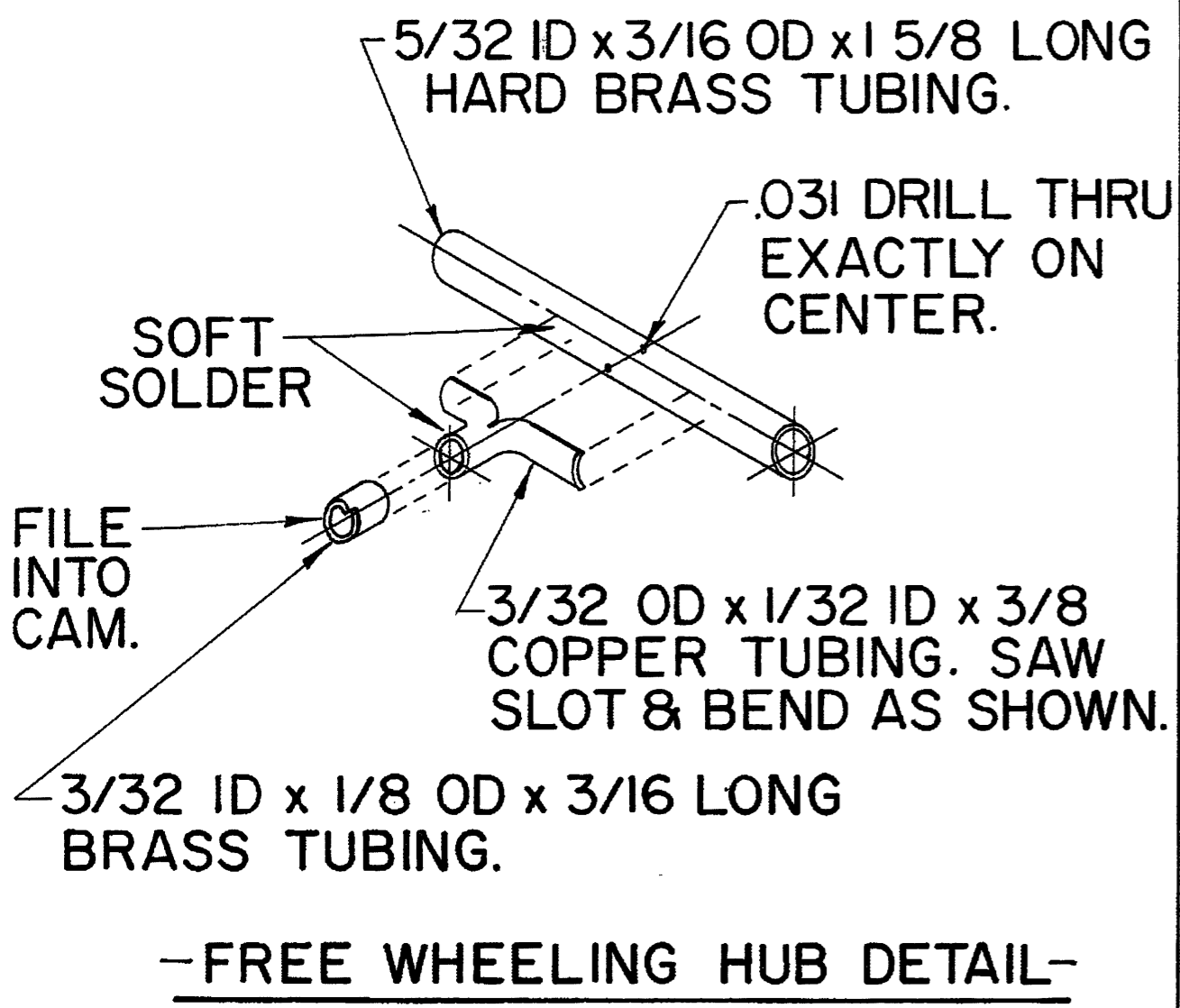

-STAB WEIGHTS-
 FRAME: .7 GM
 COVERED: 1.6 GM

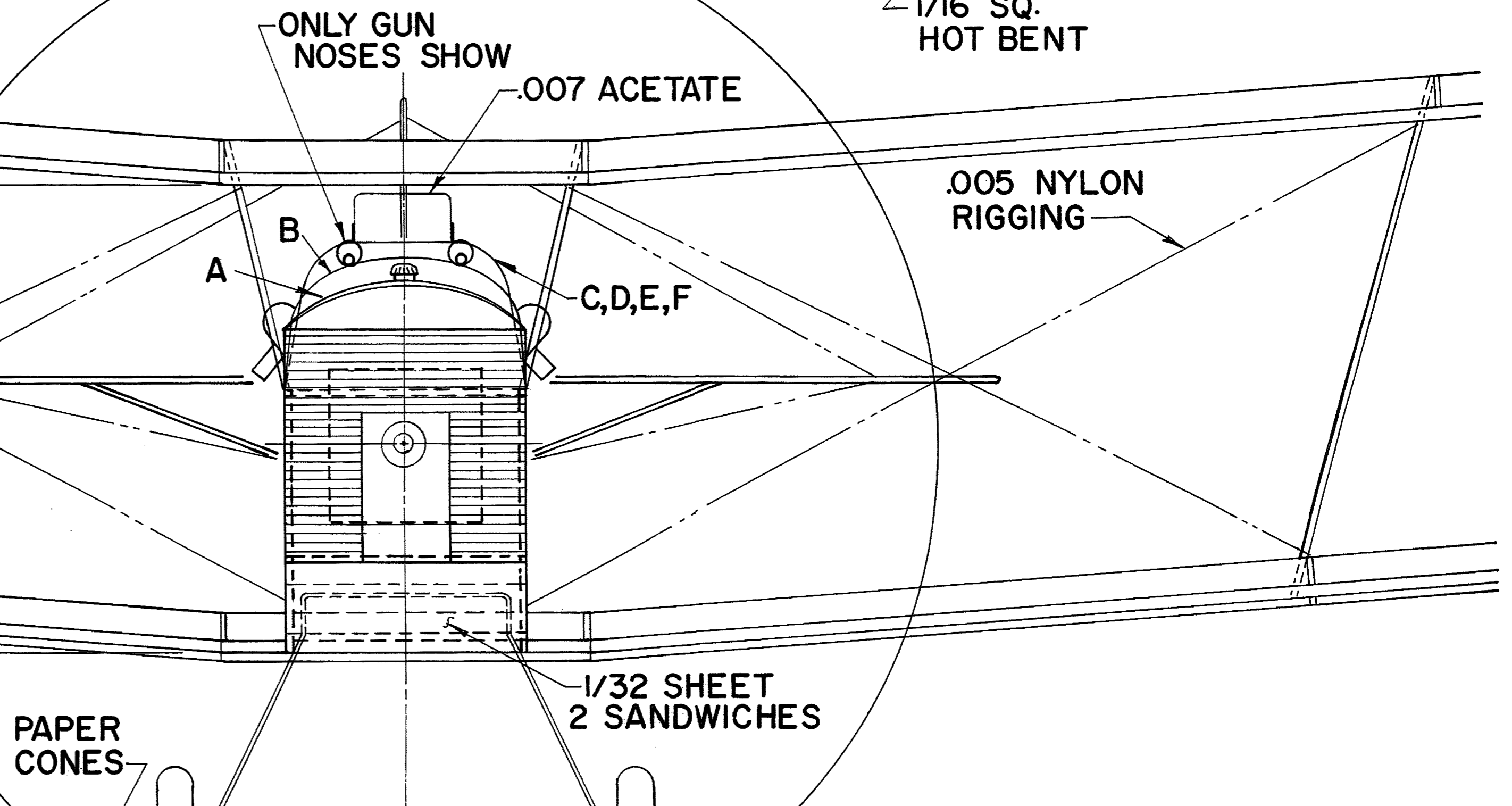
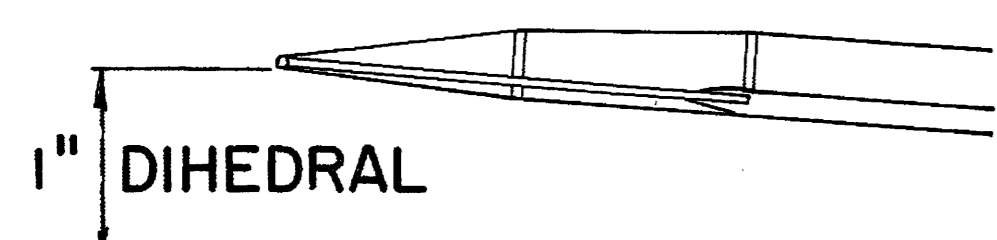

-RUDDER WEIGHTS-
 FRAME: .3 GM
 COVERED: .6 GM



10 1/2 DIA. ADJUSTABLE PITCH PROP

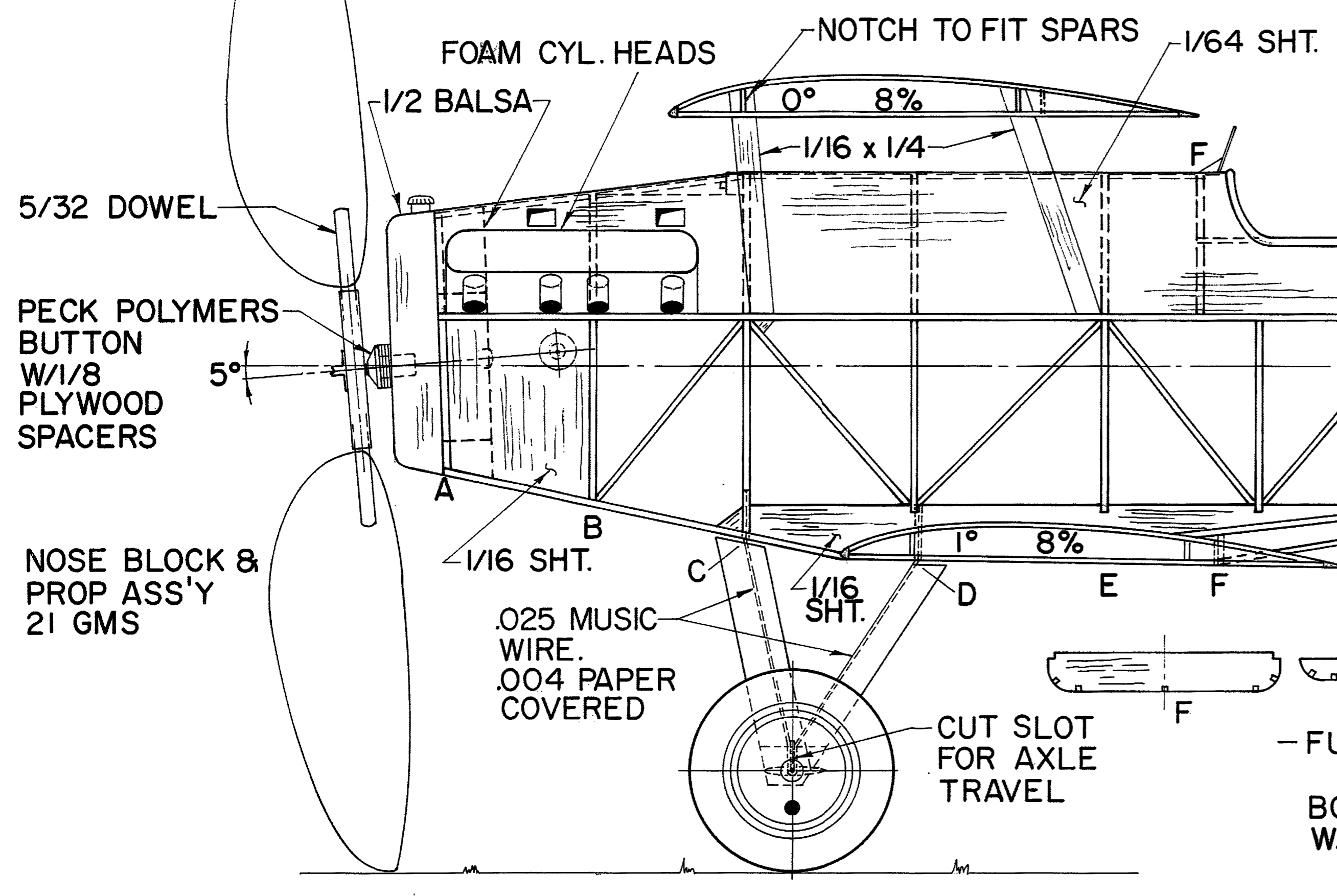

-FUSELAGE WEIGHTS-
 2 SIDES: 2.5 GM
 BOX W/ DIAGONALS: 3.4 GM
 W/ FORMERS & STRINGERS: 5.9 GM

1918 MARTINSYDE F-4 BUZZARD
 FOR FAC WWI MASS LAUNCH EVENTS
 BY DAVE REES 1 APRIL 93

D4356