

ALL WOODS ARE BALSA UNLESS STATED OTHERWISE

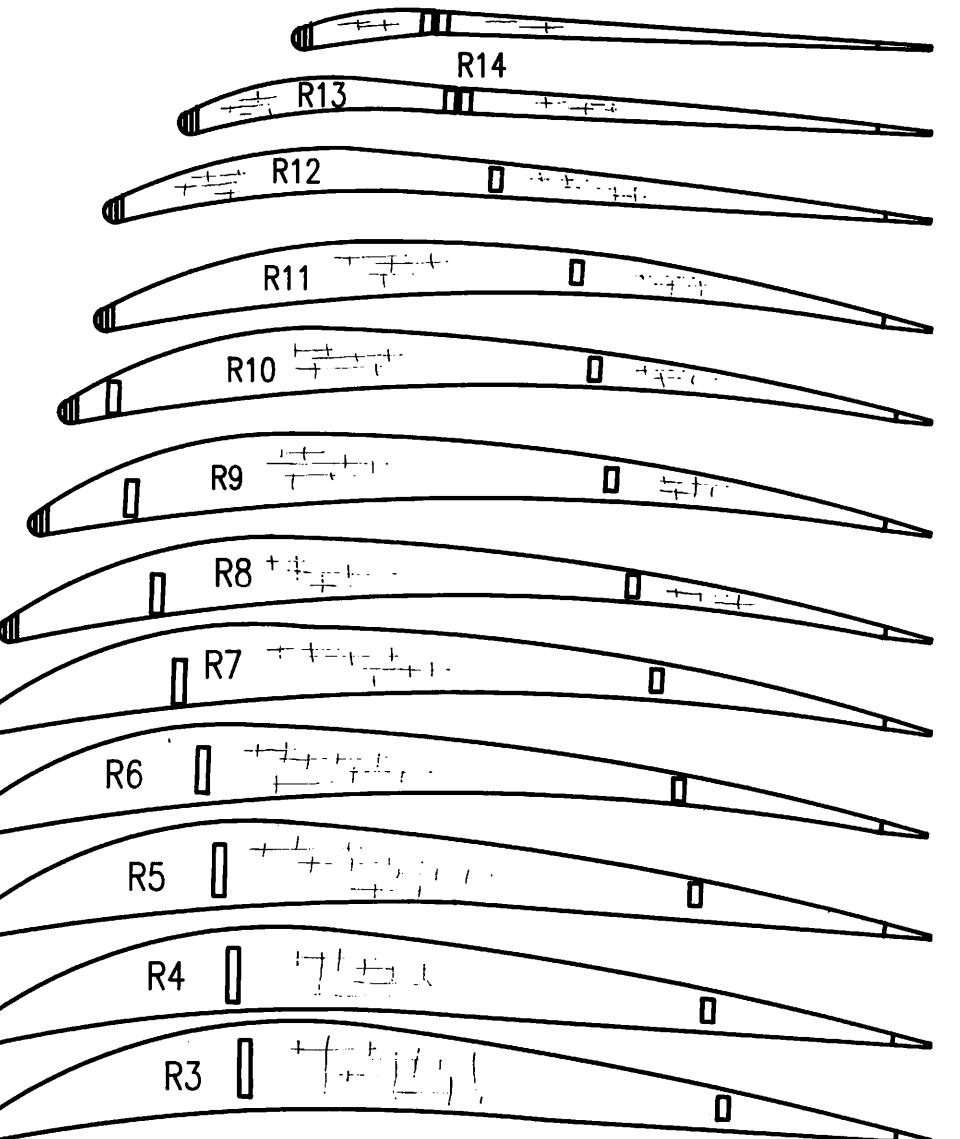

HANDLEY PAGE-E
(YELLOW PERIL)
600mm SPAN FREE FLIGHT SCALE MODEL
FOR ELECTRIC KP01 POWER
BY J.H.WATTERS

All wing ribs are 1/32" sheet except R1 & R11 which are 1/16" sheet

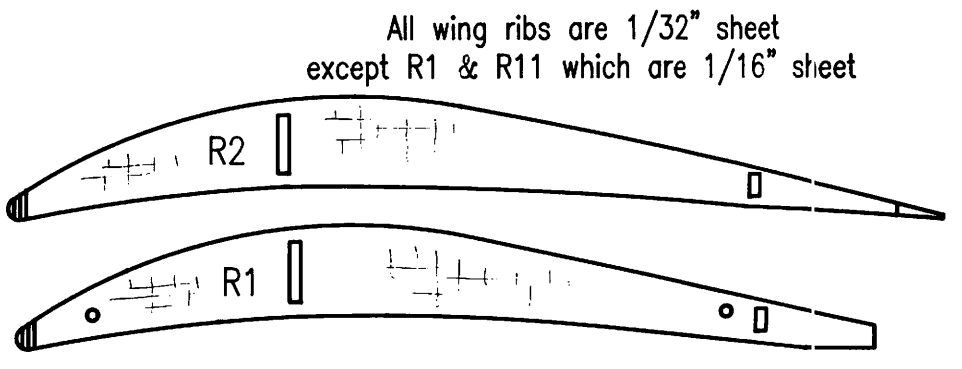
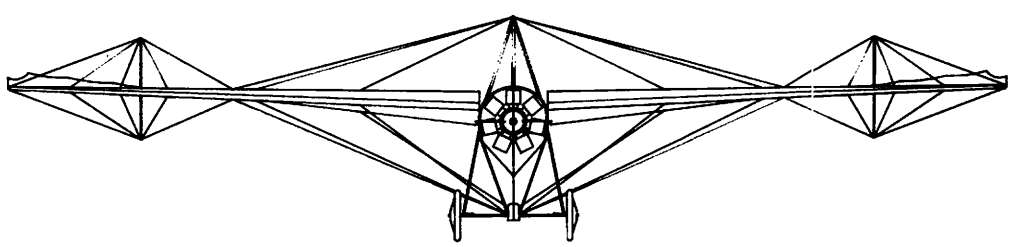
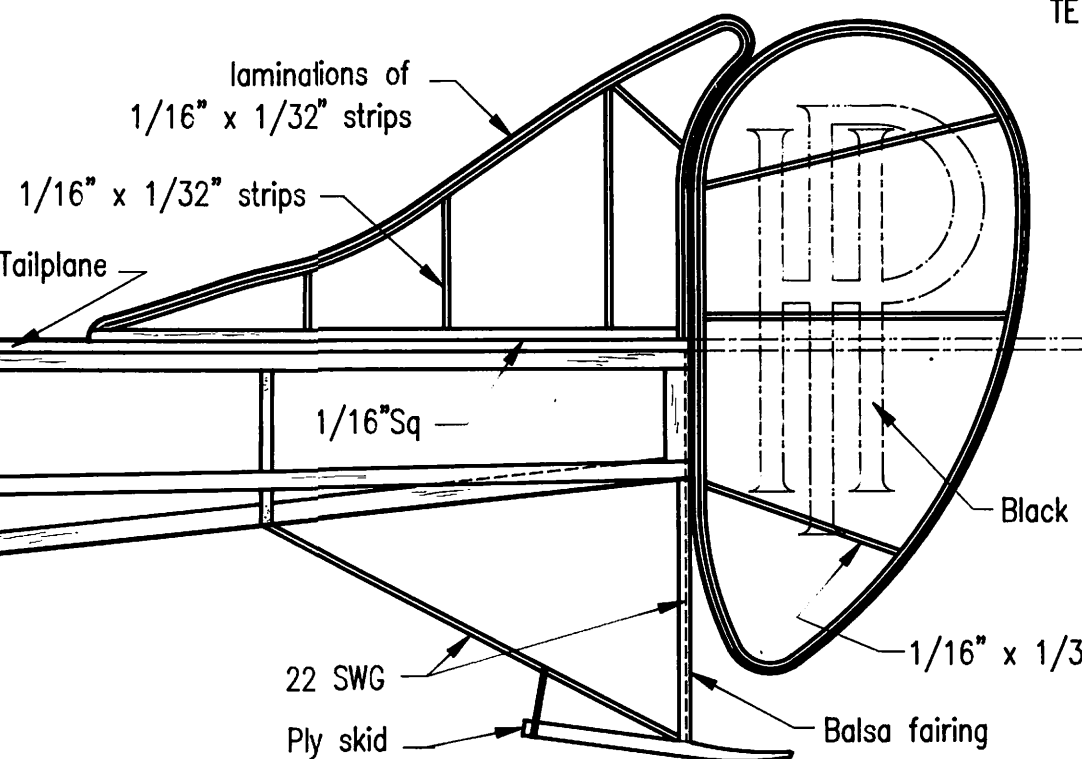
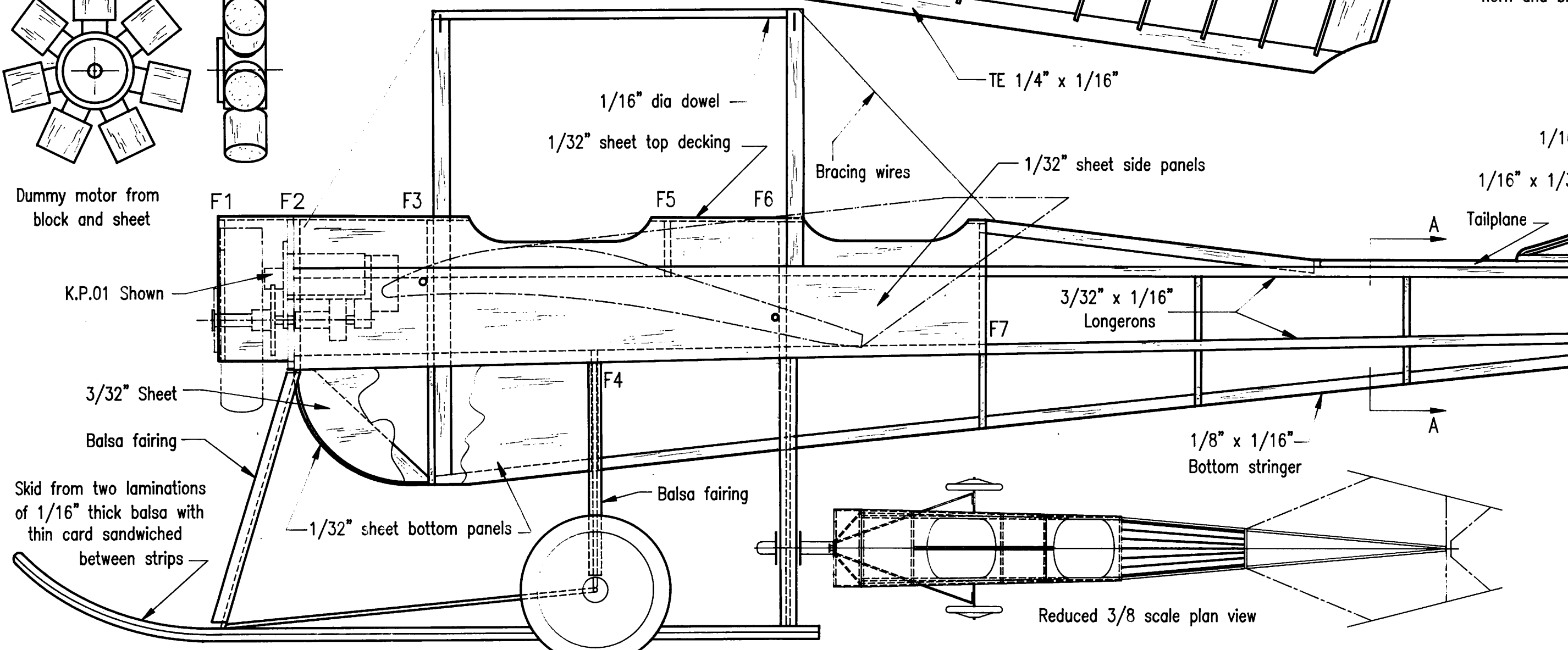
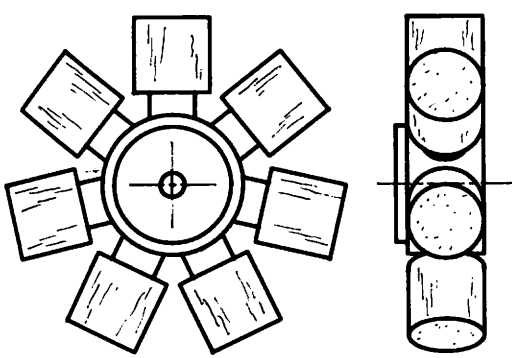
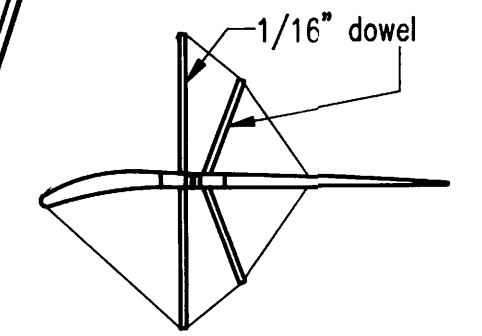
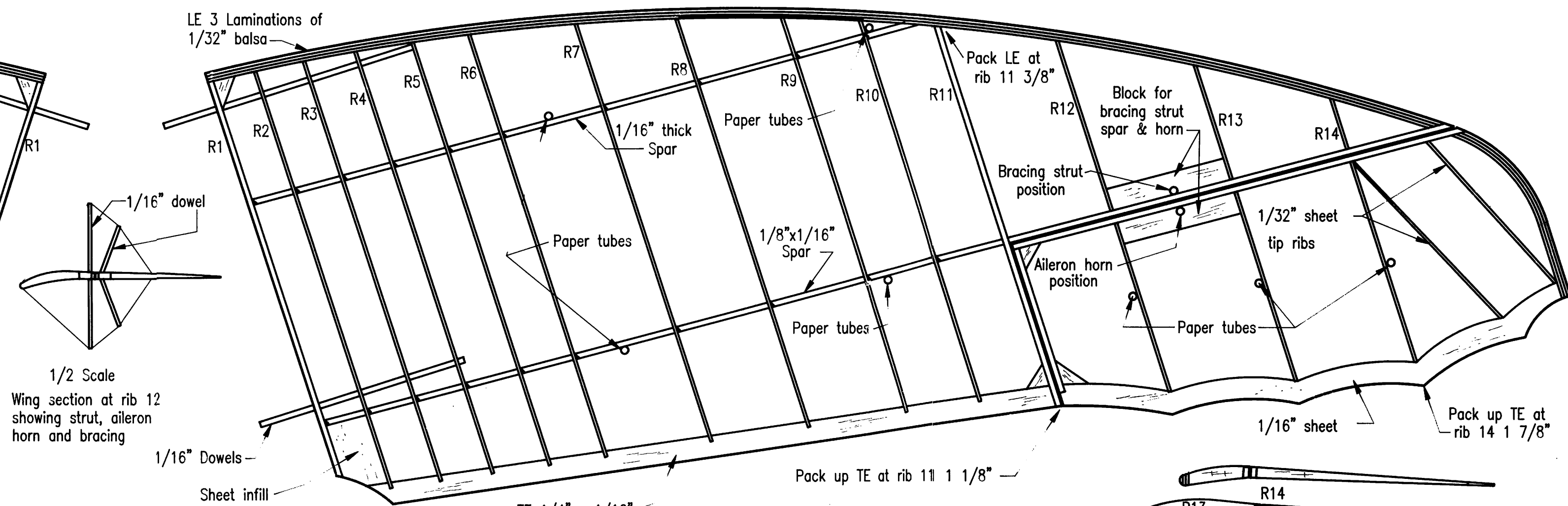
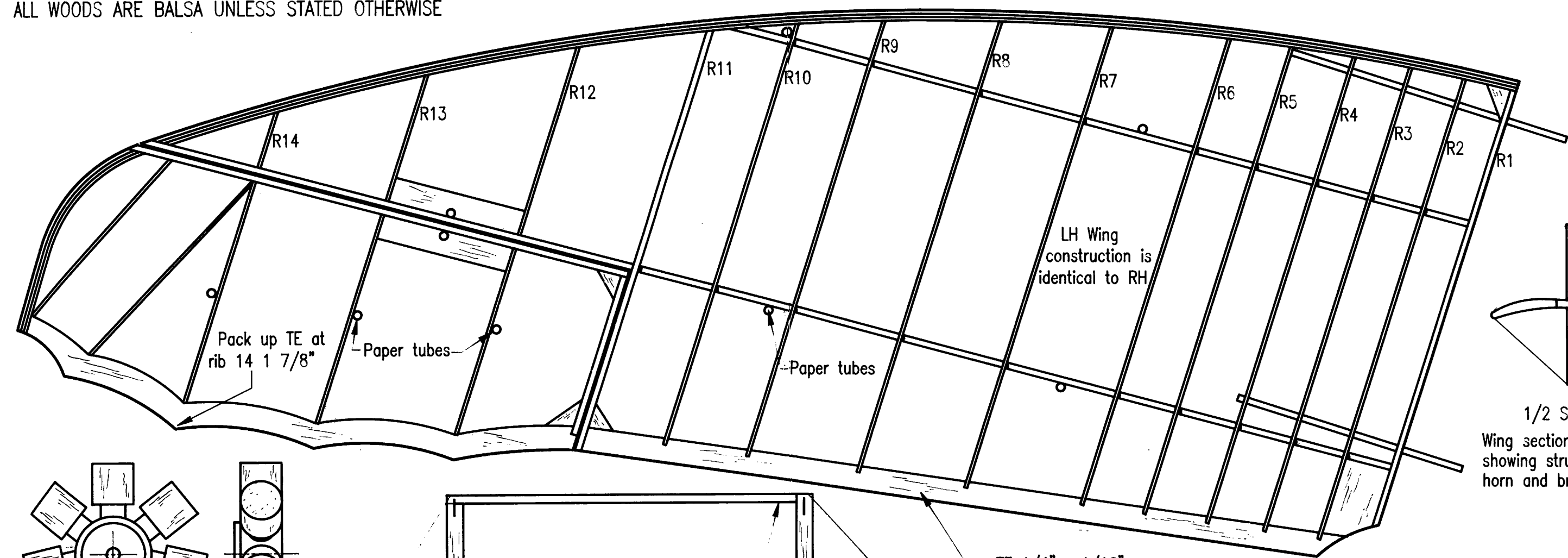
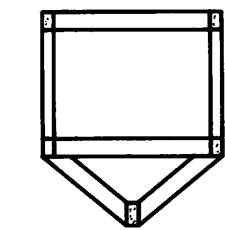

Section A-A
Typical fuselage
cross section

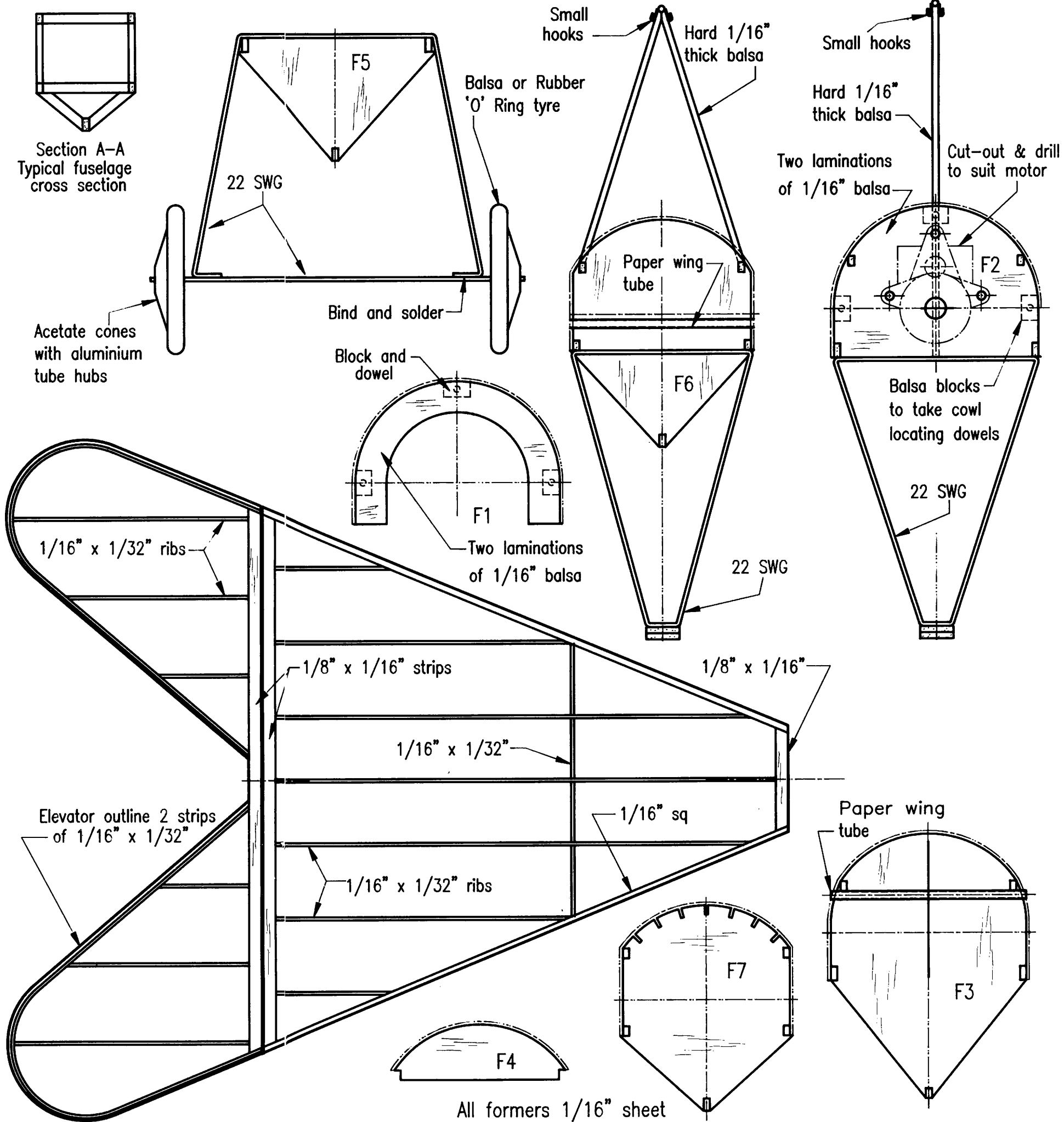

All formers 1/16" sheet