

Pin for nose block fixing

Pins for wing fixing

Elastic band

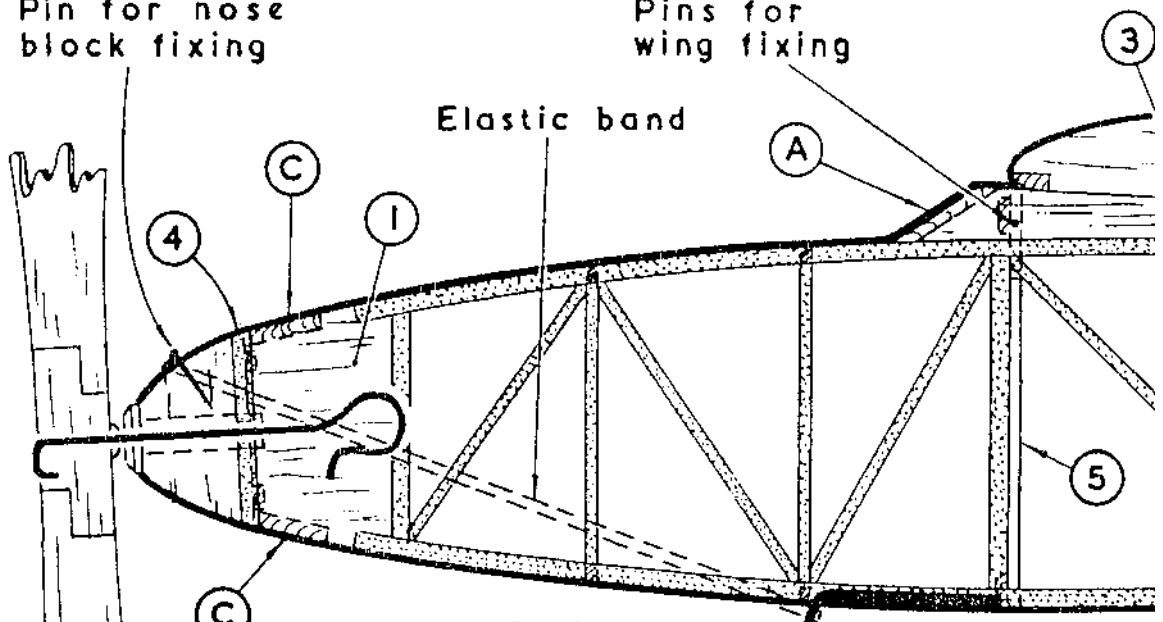

$3/32$ " x $1/16$ " strips

Strips cemented to all bulkheads

FIG 2. Bulkheads to fuselage side

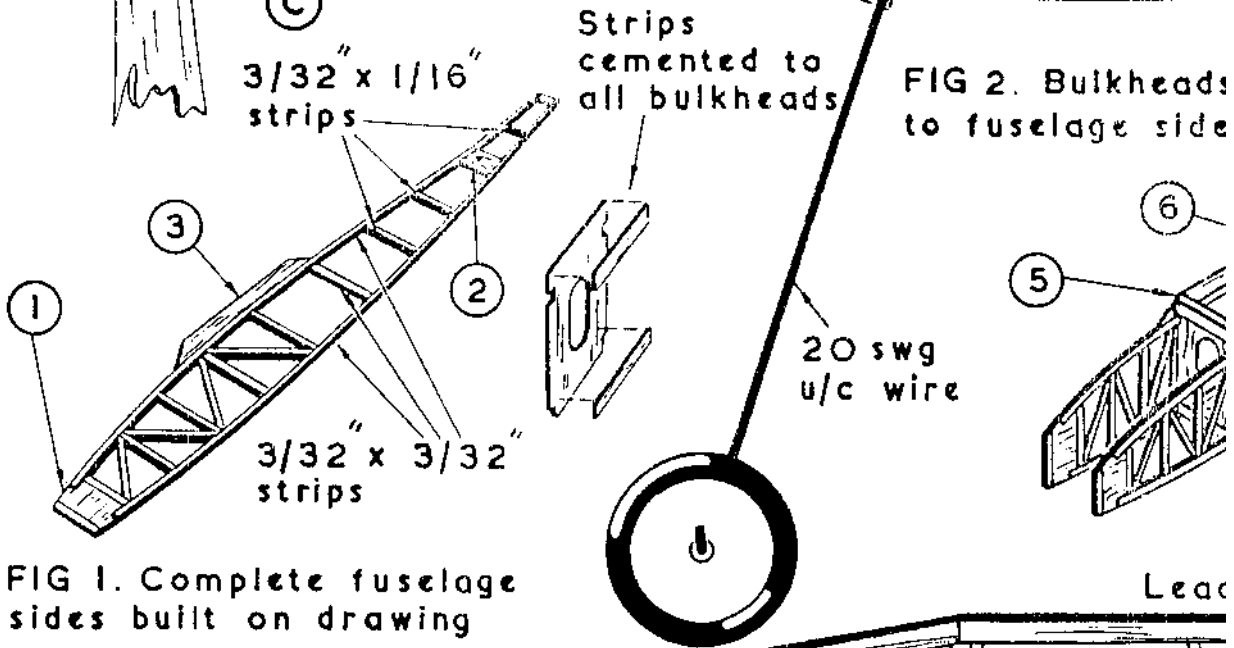
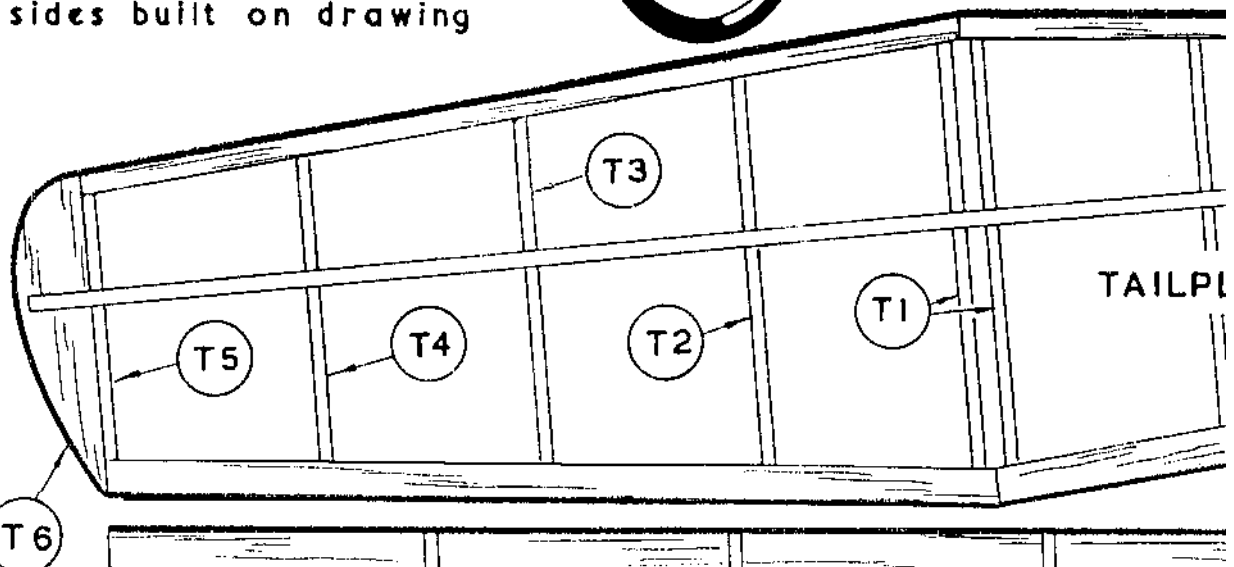
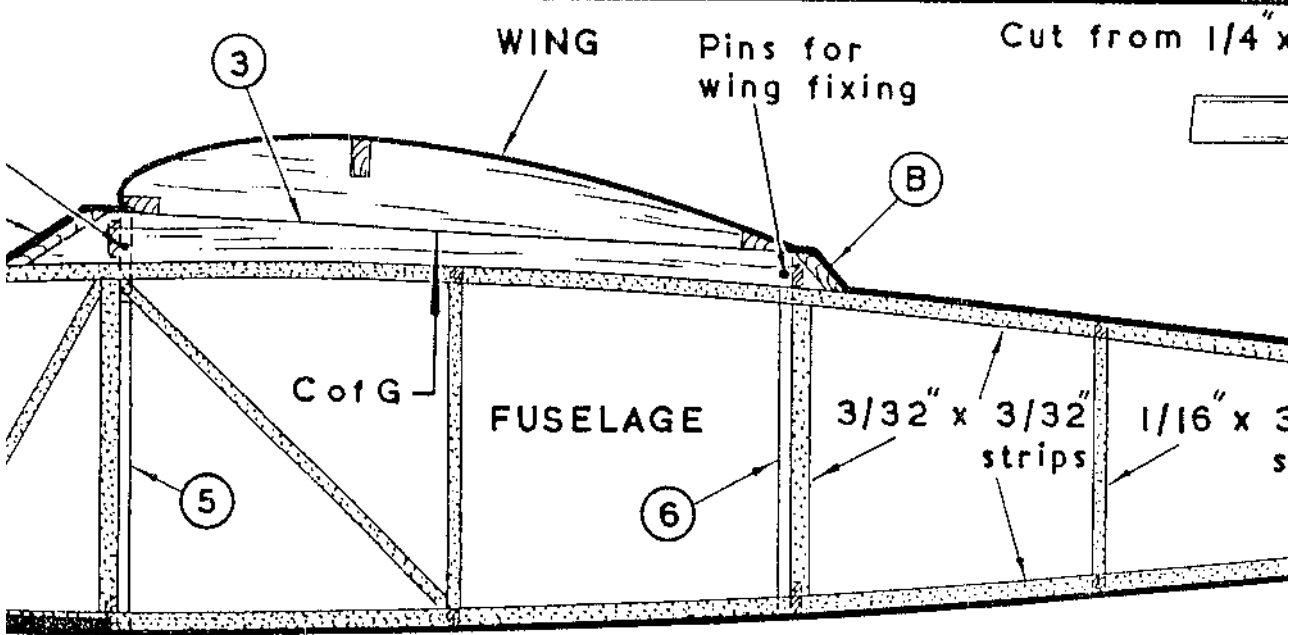

FIG 1. Complete fuselage sides built on drawing





2. Bulkheads 5 and 6 assembled fuselage sides

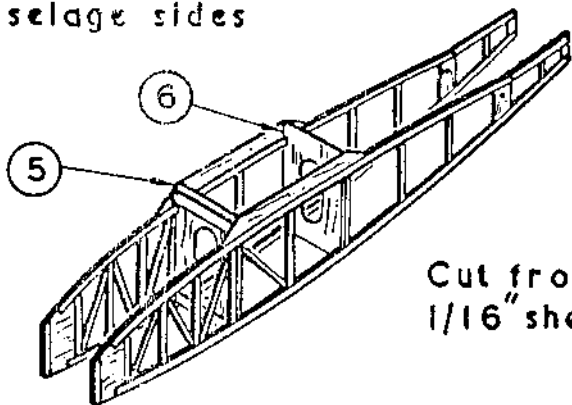

FIG 3. Bulkheads 4, 7 and cross struts cemented in place

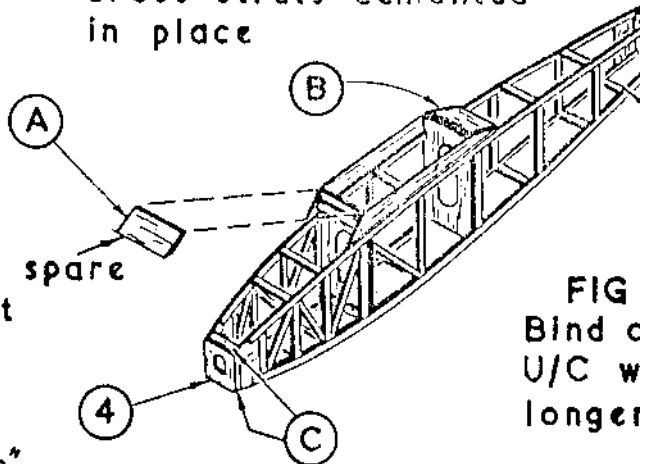
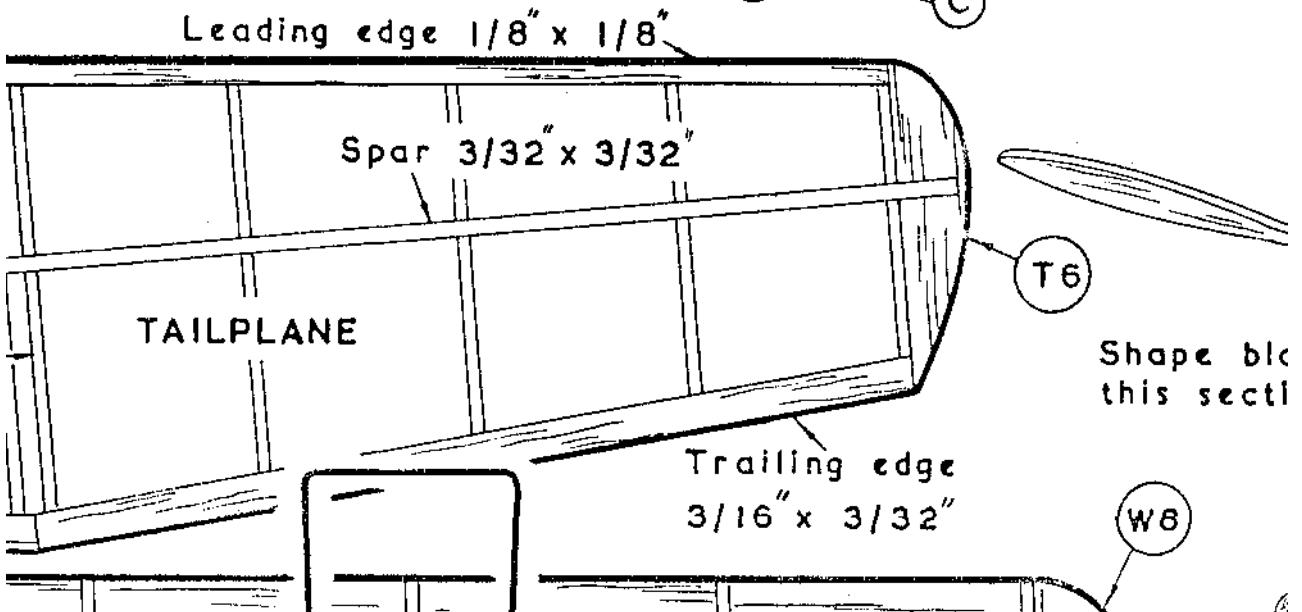

FIG Bind c U/C w longer



Shape ble this secti

SPORTS MODEL

SPECIFICATION :

WING AREA	58 sq. in.
LENGTH (O.A.)	16 in.
WEIGHT	3/4 oz.

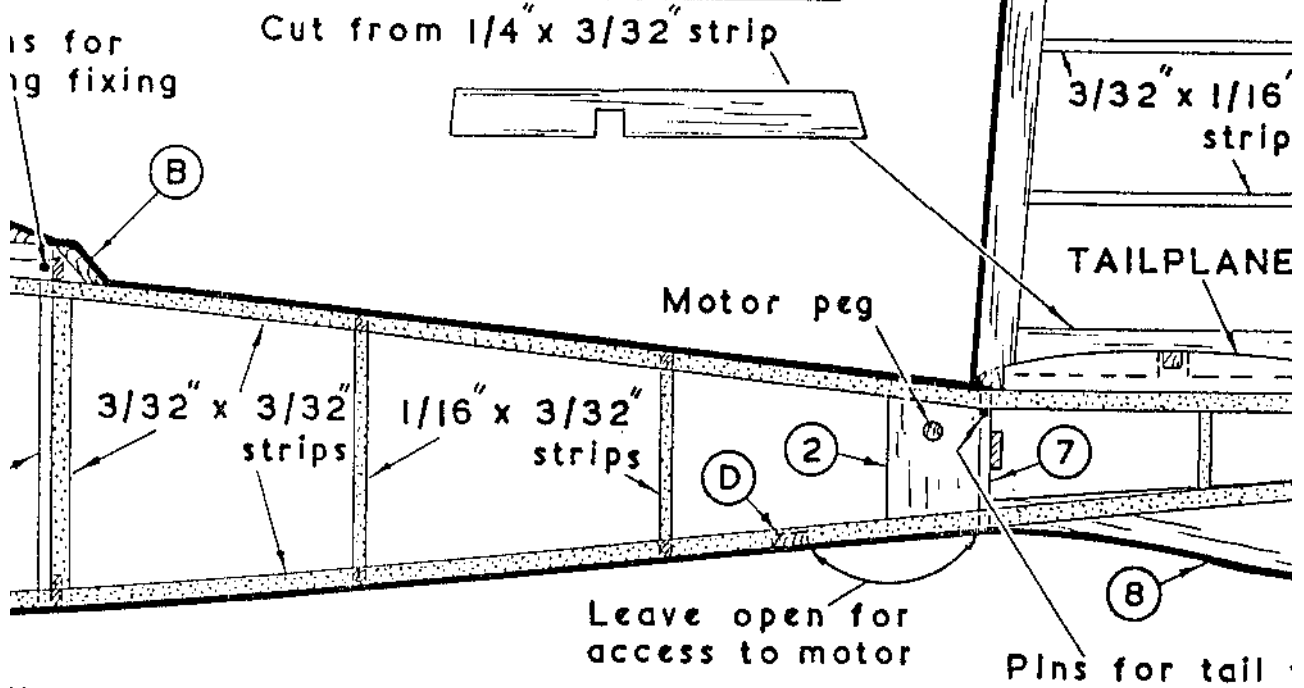

FIG 3. Bulkheads 4, 7 and cross struts cemented in place

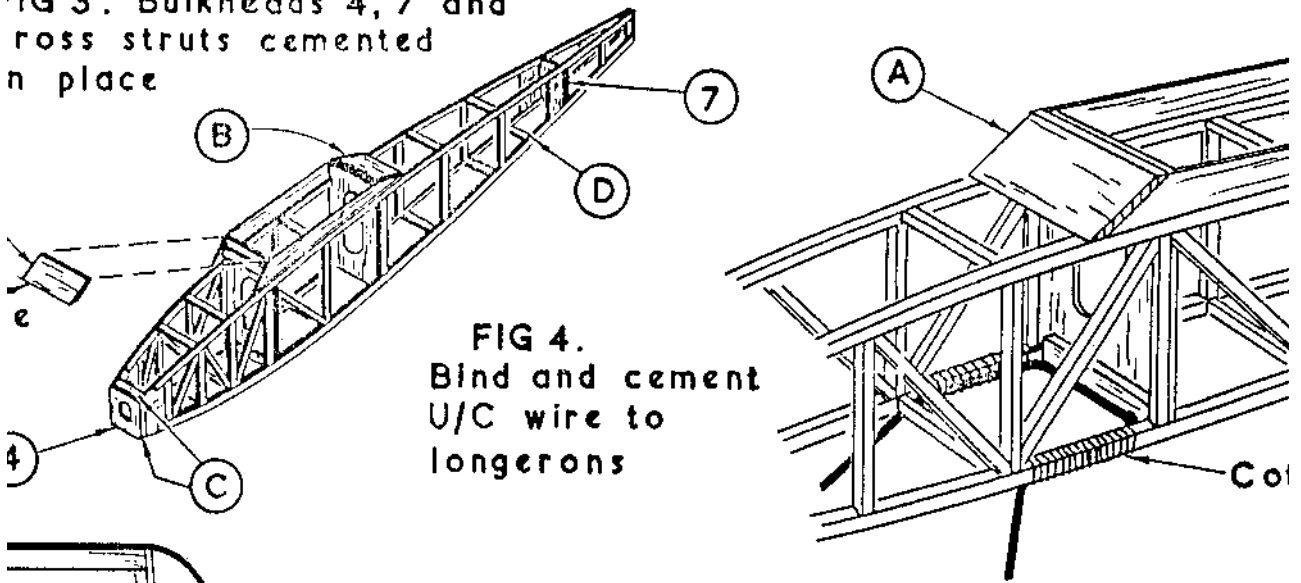

FIG 4. Bind and cement U/C wire to longerons

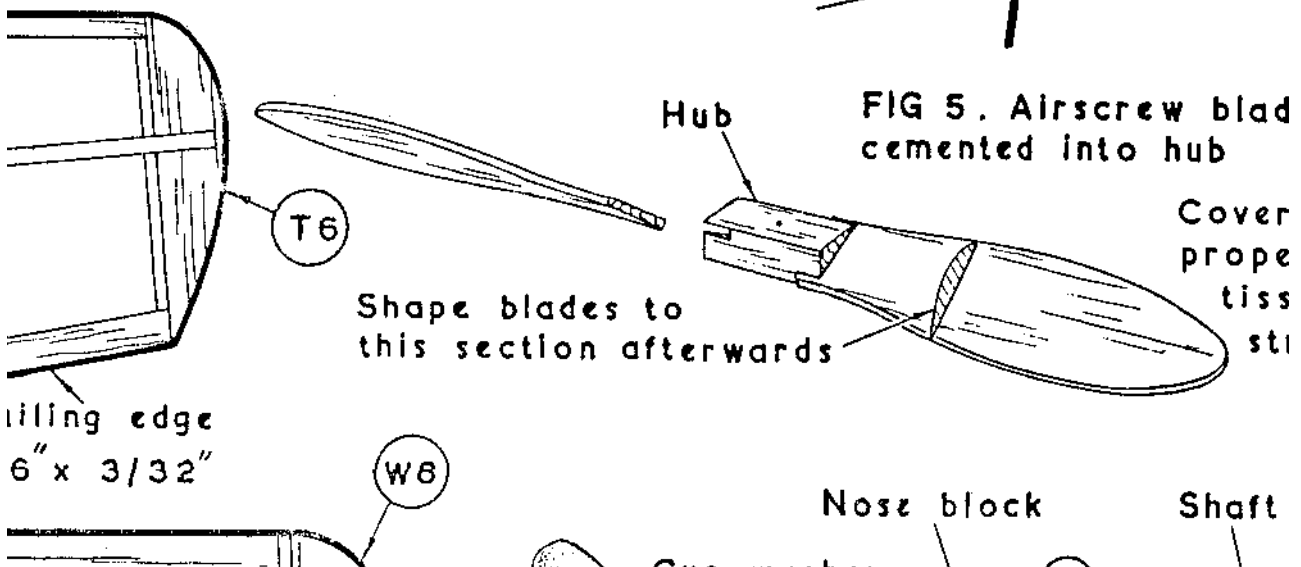
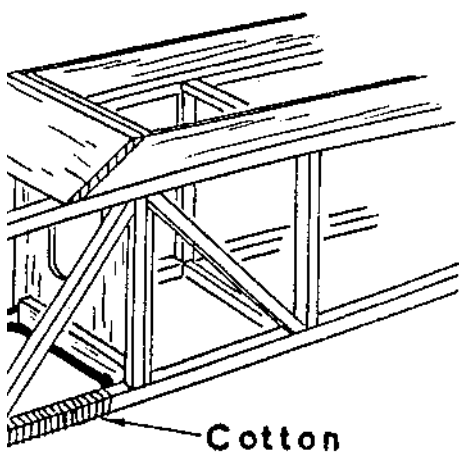
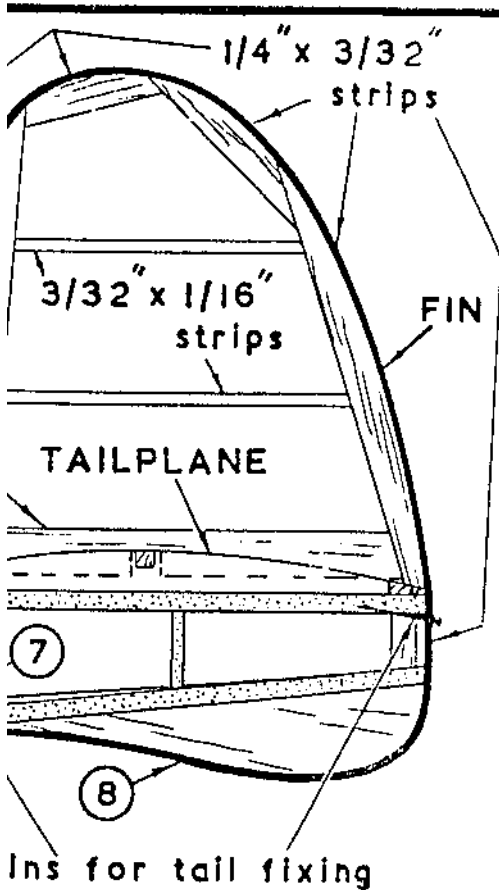

FIG 5. Airscrew blade cemented into hub



airscrew blades well
into hub

Cover finished
propellor with
tissue to
strengthen it

Shaft

BUILDING INSTRUCTIONS.

Before commencing to build the model, read the instructions carefully and protect the plan by placing a sheet of greaseproof paper over it. Use Frog Universal Cement for assembling.

FUSELAGE.

This consists of two frames composed of longerons and spacers, to which are cemented the bulkheads, etc. Begin by laying parts (1), (2) and (3) over the drawing, holding them in place with pins. Cement the longerons in place holding them in position with pins placed either side where necessary. Note that the top longeron must be cracked, at bulkhead (7), see drawing. Cut the spacers from $3/32$ in. x $1/16$ in. strip to length, but before cementing them into position duplicate each one for the remaining side, see Fig. 1. Build the second side over the first to ensure that they are identical, with small pieces of spare $1/16$ in. sheet between parts (1), (2) and (3). When the cement is thoroughly dry, separate the sides with a razor blade.

Strips of spare $1/16$ in. sheet are cemented to all bulkheads to stiffen them. When dry, assemble bulkheads (5) and (6) to the fuselage sides, see Fig. 2. Next fit bulkheads (4) and (7), holding the assembly together with small elastic bands, and cement the fuselage together at the tail, Fig. 3. Cut cross-struts to length and cement in place. Cut parts A, B, C and D to shape from spare $1/16$ in. sheet, and cement them in place; finally cement part (8) in position. Then sandpaper lightly all over. Form the wire undercarriage, first to the shape shown on the drawing and then bend back the top as shown in the side view drawing. Then bind and cement it to the inside faces of the longerons, Fig. 4. Bend the wire to form the wheel axles at approx. 4in. down each leg from the fuselage. Fit the wheels and bend up the ends of the axles.

NOSEPIECE AND AIRSCREW.

Cement the airscrew blades firmly into the diagonal slots in the hub. When dry, sandpaper the blades to section and round off the edges of the hub. Cement part (9) to the nose block, together with the plastic bush. Shape the nose block and sandpaper smooth. Pass the airscrew shaft through the nose block, cup washer and airscrew, bend over the end and cement it into the airscrew as shown on the side-view drawing.

WING.

This consists of two half-wings and a centre section built flat on the drawing, and then the half-wings raised at the tips to the correct dihedral angle. Place the Leading Edges and Trailing Edges over the drawing holding them in position with pins. Cement the ribs (W2) — (W7) in place, then shape the main spars at each end (see section of wing at spar) and cement into position. Then cement tip pieces (W8) in place. Build the centre-section in the same manner, pinning down the Leading and Trailing Edge pieces and cementing ribs (W1) to them. Cut strips of $3/16$ in. x $3/32$ in. to length and cement them in place between the ribs and against the Leading and Trailing Edges.

Cement the port and starboard wings to the centre section with the tips raised to $1\frac{1}{2}$ in., the spars being braced at the centre with a strip of $1/4$ in. x $3/32$ in., Fig. 7. Parts (E) are cut from spare $1/16$ in. sheet and cemented in place. Shape the Leading and Trailing Edges to the section shown on side view drawing and sandpaper smooth.

TAILPLANE.

This is constructed in a similar manner to the wings. Pin down the Leading and Trailing Edges, cementing them at the centre, followed by the ribs (T1) — (T5). Chamfer the ends of the spar, and cement spar and tips in place together. Sand the edges to shape, and smooth down the whole tail.

FIN.

Cut the base piece to shape and pin into place; build the rest from $1/4$ in. x $3/32$ in. strip and $3/32$ in. x $1/16$ in. strip. Round off the edges and sandpaper smooth. Assemble the finished fin to the Tailplane after they are covered.

COVERING.

Cover the parts in the following order:— Fuselage sides, top and bottom. Wing and tailplane under-surfaces, then top surfaces. Fin, each side separately. Cut the tissue, allowing approx. $\frac{1}{2}$ in. overlap all round. Paste the framework and place the tissue into position. Do not attempt to pull the tissue drum-tight but aim at covering each part uniformly with no

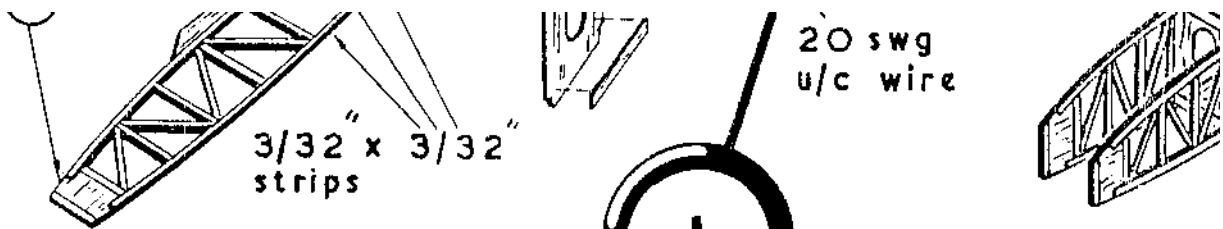
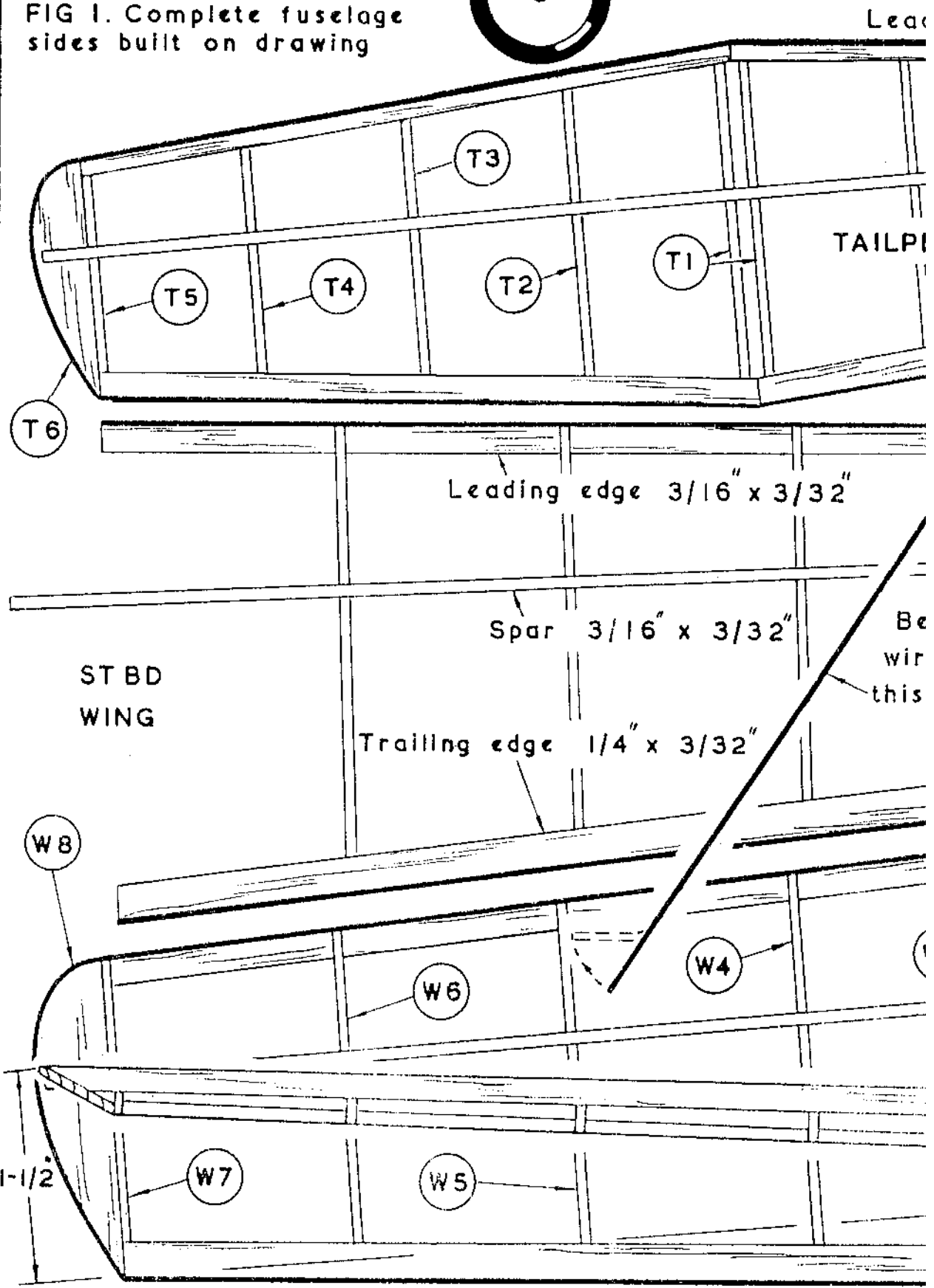
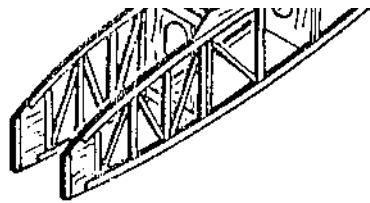

FIG 1. Complete fuselage sides built on drawing



2



Cut from spare 1/16" sheet

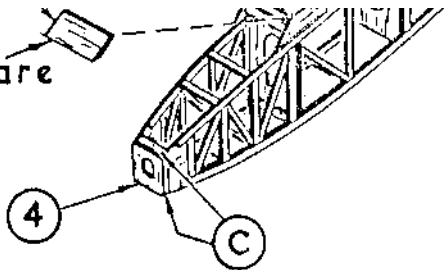

FIG
Blind
U/C
longe

Leading edge 1/8" x 1/8"

Spar 3/32" x 3/32"

TAILPLANE

T6

Shape bl
this sect

Trailing edge
3/16" x 3/32"

W6

Prop

5" x 3/32"

3/32"

Bend u/c
wire to
this shape

12"

PORT
WING

W3

E

W1

W2

SECTION AT SP.

E

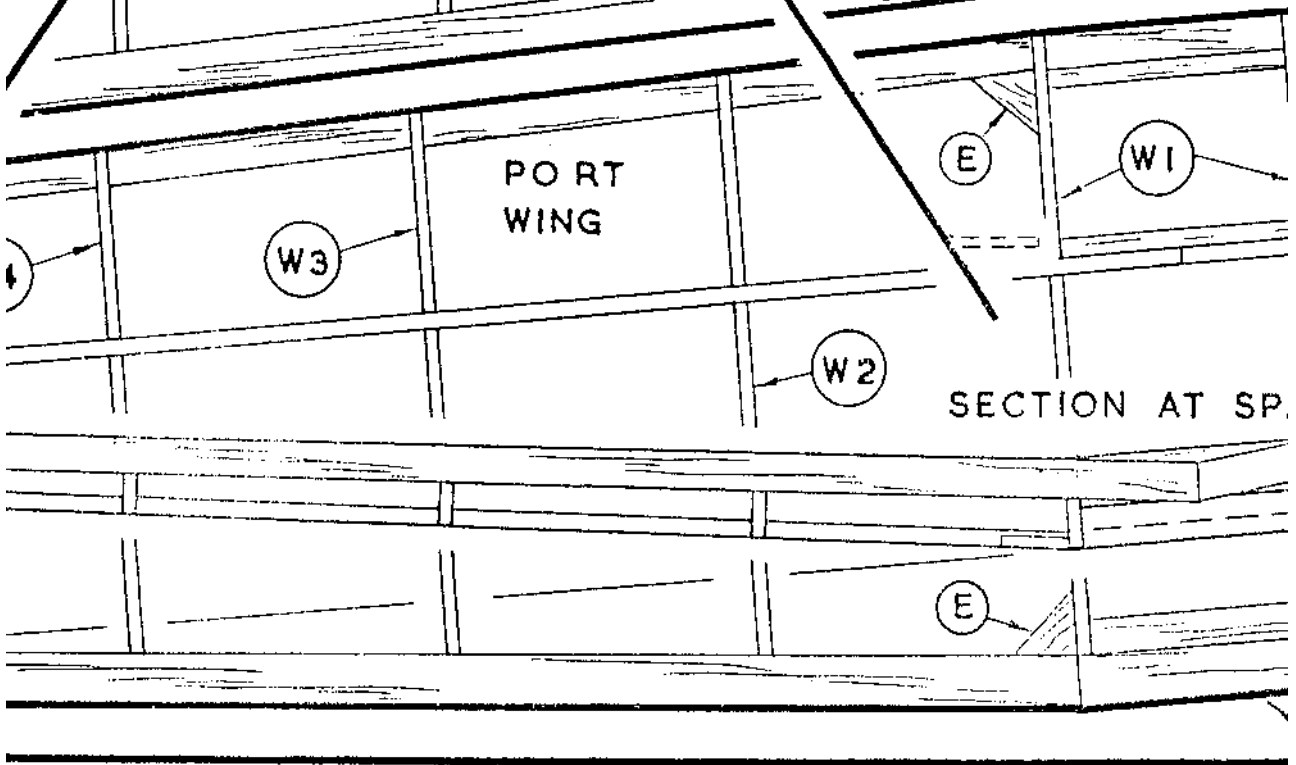

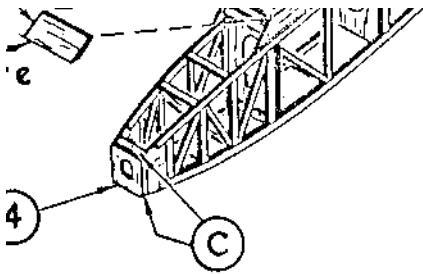

FIG 4.
Bind and cement
U/C wire to
longerons

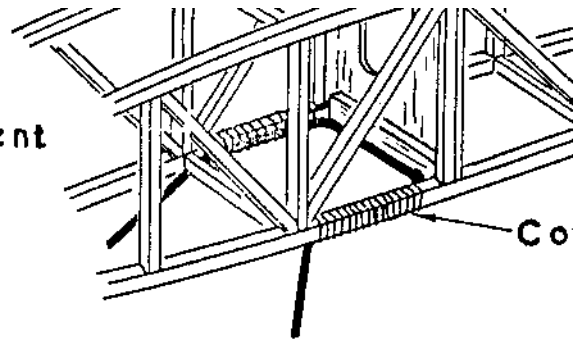
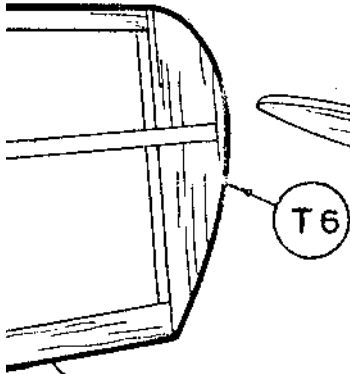
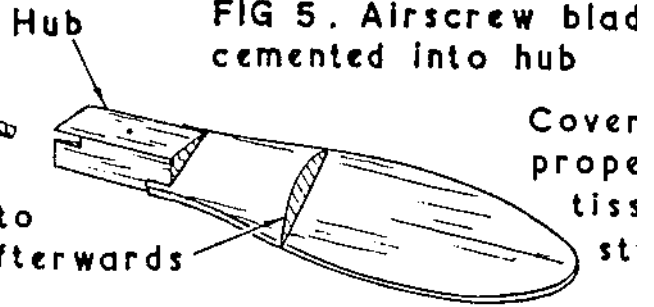

FIG 5. Airscrew blade
cemented into hub



Shape blades to
this section afterwards



Cover
propeller
with
st

Leading edge
6" x 3/32"

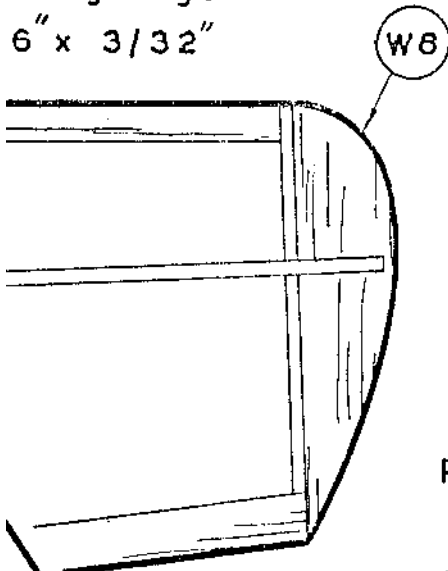

Propellor

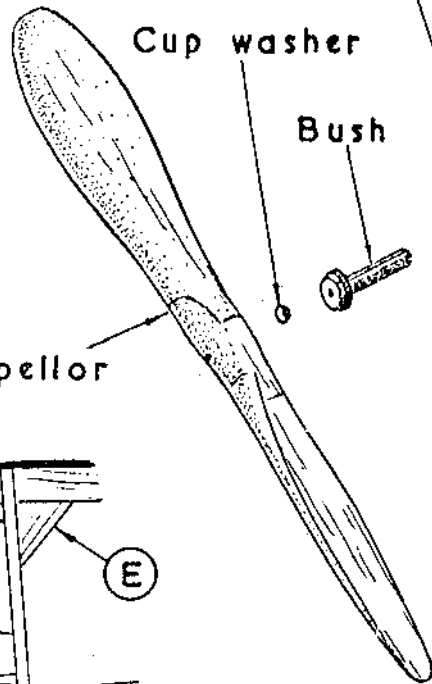

Nose block

Shaft

Cup washer

Bush

9

FIG 6
propeller
assembly

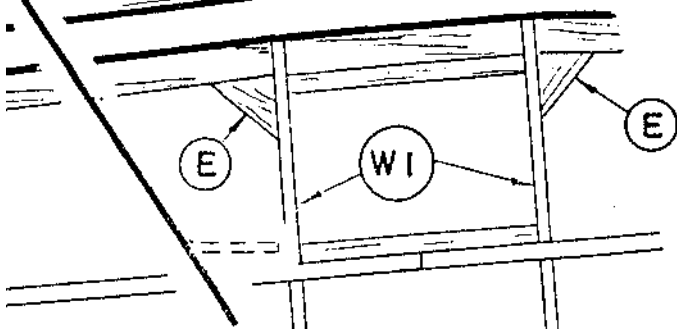

SECTION AT SPAR

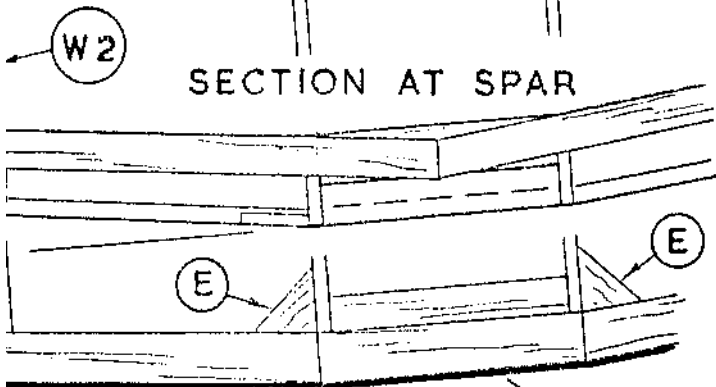

CENTRE SECTION

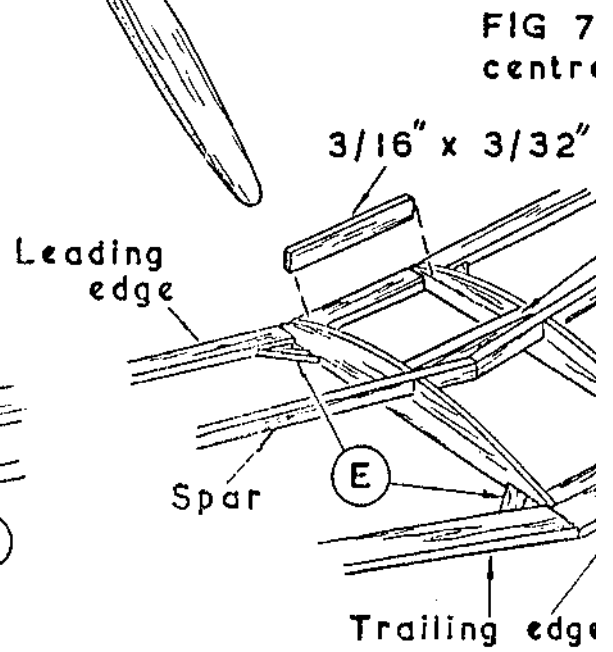

FIG 7
centre

3/16" x 3/32"

Leading edge

Spar

Trailing edge

Designed

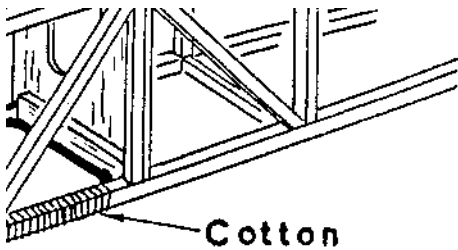

Cotton

Airscrew blades well into hub

Cover finished propellor with tissue to strengthen it

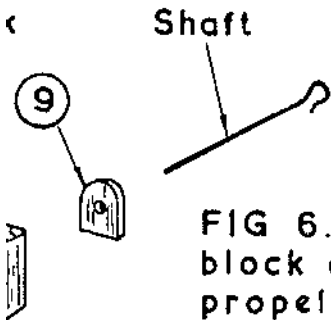
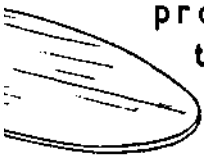
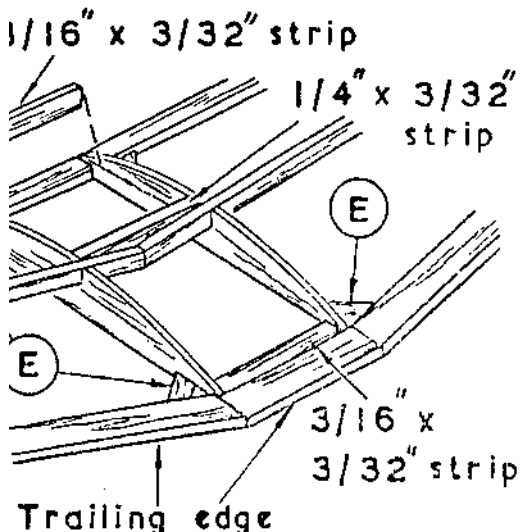

FIG 6. Nose block and propellor assembly

FIG 7. Wing centre section



Designed by R.S.P.

flat on the drawing, and then the half-wings raised at the tips to the correct dihedral angle. Place the Leading Edges and Trailing Edges over the drawing holding them in position with pins. Cement the ribs (W2) — (W7) in place, then shape the main spars at each end (see section of wing at spar) and cement into position. Then cement tip pieces (W8) in place. Build the centre-section in the same manner, pinning down the Leading and Trailing Edge pieces and cementing ribs (W1) to them. Cut strips of $3/16$ in. x $3/32$ in. to length and cement them in place between the ribs and against the Leading and Trailing Edges.

Cement the port and starboard wings to the centre section with the tips raised to $1\frac{1}{2}$ in., the spars being braced at the centre with a strip of $1/4$ in. x $3/32$ in., Fig. 7. Parts (E) are cut from spare $1/16$ in. sheet and cemented in place. Shape the Leading and Trailing Edges to the section shown on side view drawing and sandpaper smooth.

TAILPLANE.

This is constructed in a similar manner to the wings. Pin down the Leading and Trailing Edges, cementing them at the centre, followed by the ribs (T1) — (T5). Chamfer the ends of the spar, and cement spar and tips in place together. Sand the edges to shape, and smooth down the whole tail.

FIN.

Cut the base piece to shape and pin into place; build the rest from $1/4$ in. x $3/32$ in. strip and $3/32$ in. x $1/16$ in. strip. Round off the edges and sandpaper smooth. Assemble the finished fin to the Tailplane after they are covered.

COVERING.

Cover the parts in the following order: — Fuselage sides, top and bottom. Wing and tailplane under-surfaces, then top surfaces. Fin, each side separately. Cut the tissue, allowing approx. $\frac{1}{2}$ in. overlap all round. Paste the framework and place the tissue into position. Do not attempt to pull the tissue drum-tight but aim at covering each part uniformly with no deep wrinkles.

DOPING.

Before doping, spray or brush lightly all covered parts with water. Spray one half wing at a time and pin down on a flat board to ensure that no warps develop whilst drying. Pin the tailplane in a similar manner. When completely dry, give each component one coat of dope, again pinning down the wings and tailplane as soon as dope begins to harden off. Do not pin down when the dope is wet as the tissue will stick to the board. Give each component one coat of dope and one of lacquer.

RUBBER MOTOR.

Tie the ends of the elastic supplied together with thread to obtain two strands, and lubricate with rubber lubricant or castor oil.

ASSEMBLY.

Hook the airscrew shaft to one end of the motor, then drop the motor through the fuselage and secure by passing the $3/32$ in. dia. cane through the side pieces (2) and the loop of elastic. Hold the Tailplane and Fin unit secure with two small elastic bands over the Tailplane. Secure the wings with bands crossed over the wing, from the front attachment pins to the rear pins. Check that all flying surfaces are free from warps.

The third elastic band is for holding the nose block in position. Push a small pin into the top of the nose block and loop the band over this pin and the undercarriage legs.

C. G. POSITION.

The completed model should balance approximately at the point shown on the Side View drawing.

FLYING.

Choose a calm day for the first test flights which should be made preferably over long grass. Wind approx. 50 turns on the airscrew and launch the model gently on an even keel. If the model is correctly trimmed it will fly straight and level. If it climbs and stalls move the wings back slightly towards the tail. If it dives, move the wings forward slightly. Once trimmed the turns may be increased by approx. 50 turns on each subsequent flight until the maximum of 400 turns is reached.

Designed and manufactured in England by
INTERNATIONAL MODEL AIRCRAFT LTD.,
Morden Road, Merton, London, S.W.19.

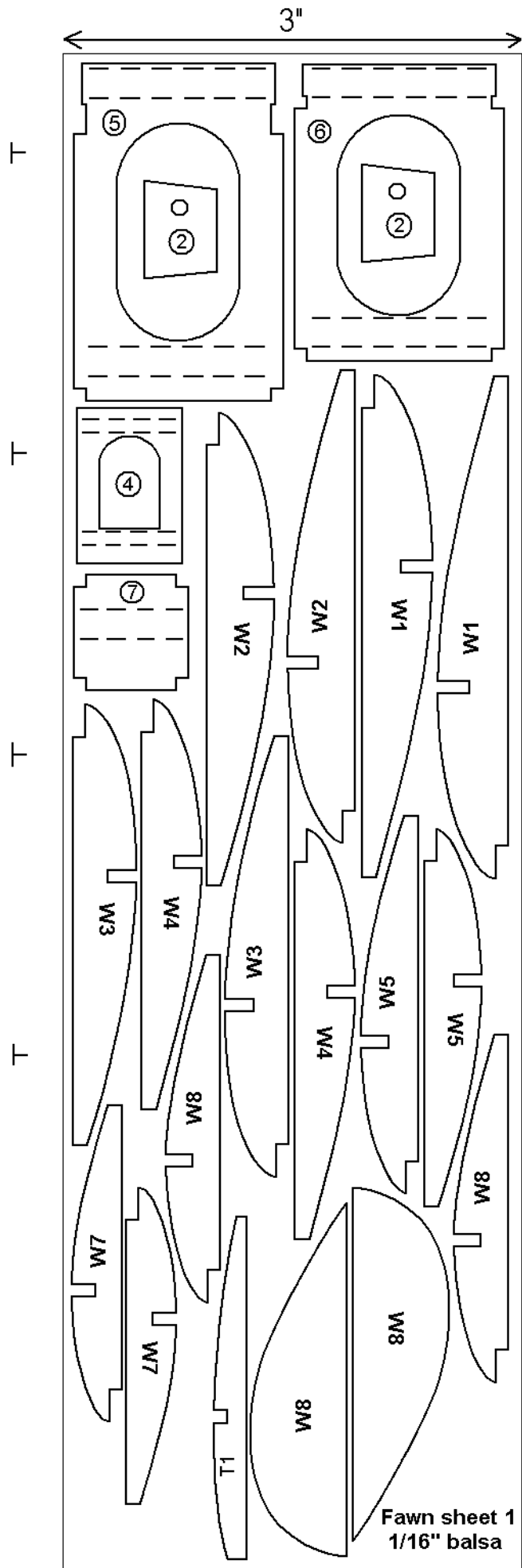

Fawn sheet 1
1/16" balsa

