

# The 'FOUGA CYCLONE' TURBO JET SAILPLANE.

SCALE MODEL for JETEX 50.

A 30" **VERON** KIT SPAN.

SKETCHES SHOWING PROGRESSIVE ASSEMBLY OF JET CASING FROM 1/2" x 1/2" BLOCKS.

STAGE 1.

STAGE 2.

STAGE 3.

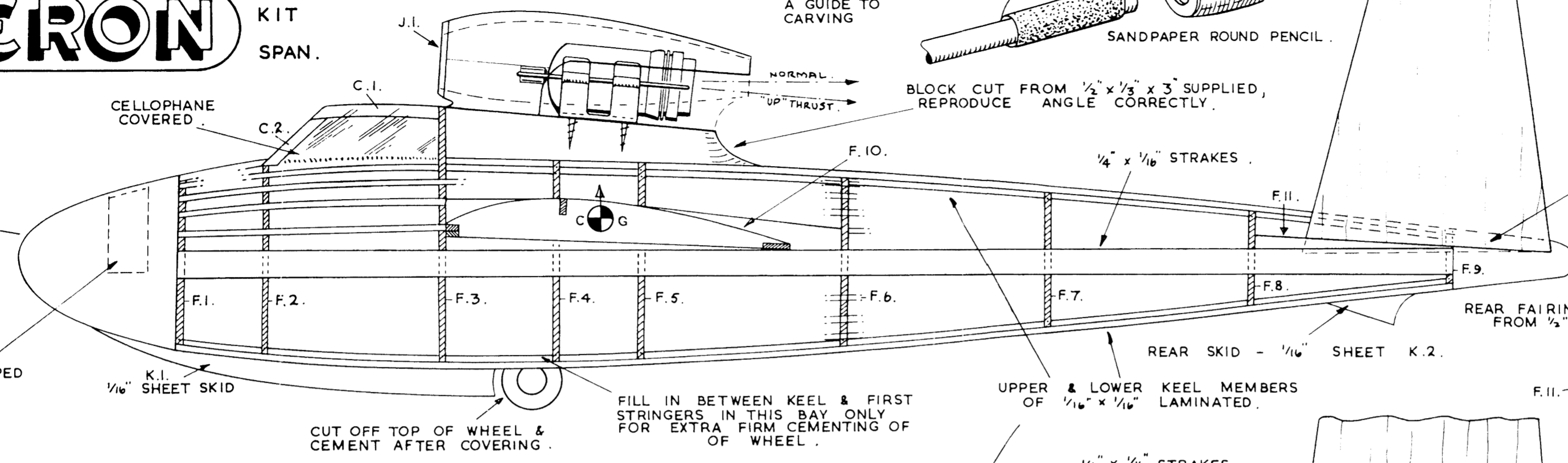
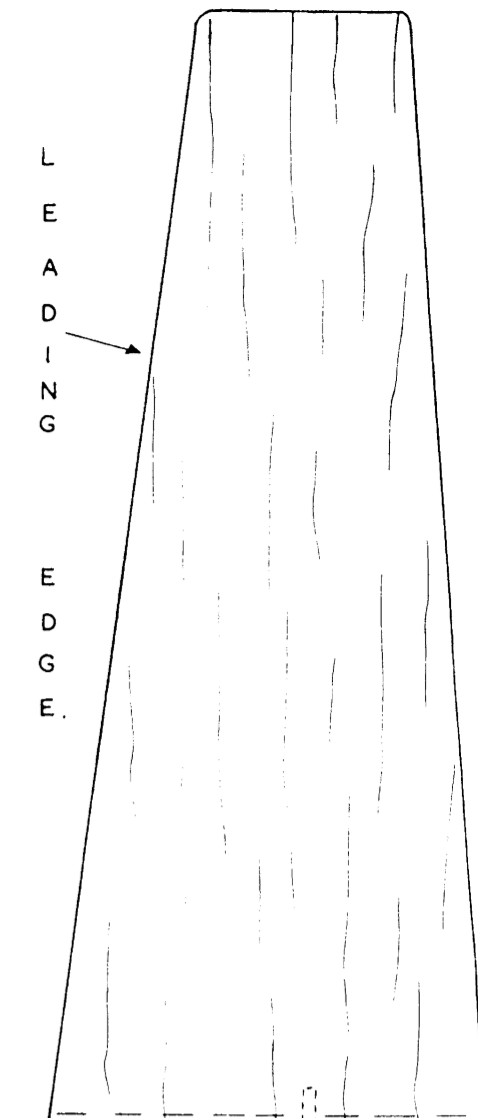
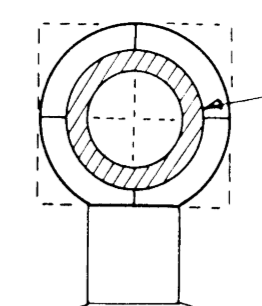
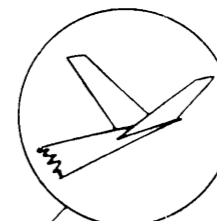

NOSE BLOCK IS ADDED AFTER ALL STRINGERS ARE IN PLACE. JOIN WITH DOUBLE COATING OF CEMENT.

USE LEAD SHOT CAPPED WITH PLASTICINE FOR BALLAST.

DRILL 3/8" HOLE BEFORE CEMENTING IN PLACE.

**PROGRESSIVE CONSTRUCTION OF FUSELAGE.**

SHOWING HOW KEELS ARE LAID FIRST OF TWO LAMINATED 1/16" x 1/16" PINS LOCATED EITHER SIDE OF STRIPS. THEN ERECT SLOTTED HALVES OF ALL FORMERS.

STAGE 1.

NEXT SKETCH SHOWS ADDITION OF ALL FORMERS WITH SIDE STRAKE OF 1/16" x 1/4" ADDED. THEN ADD 1/16" STRINGERS - THREE TO LOWER SIDES AND FOUR TO THE TOP ALL SUITABLY SPACED ABOUT OR JOINING WITH F.10. - SEE SIDE ELEVATION DRAWING ABOVE FOR RELATIVE POSITIONS.

STAGE 2.

ONLY CENTRE STRINGERS ON TOP & BOTTOM SIDES ARE CARRIED PAST F.8. TO REAR.

SECURE CLIP WITH 2 SCREWS IN JETEX KIT.

CHAMFER REAR OF BLOCK AS SHOWN.

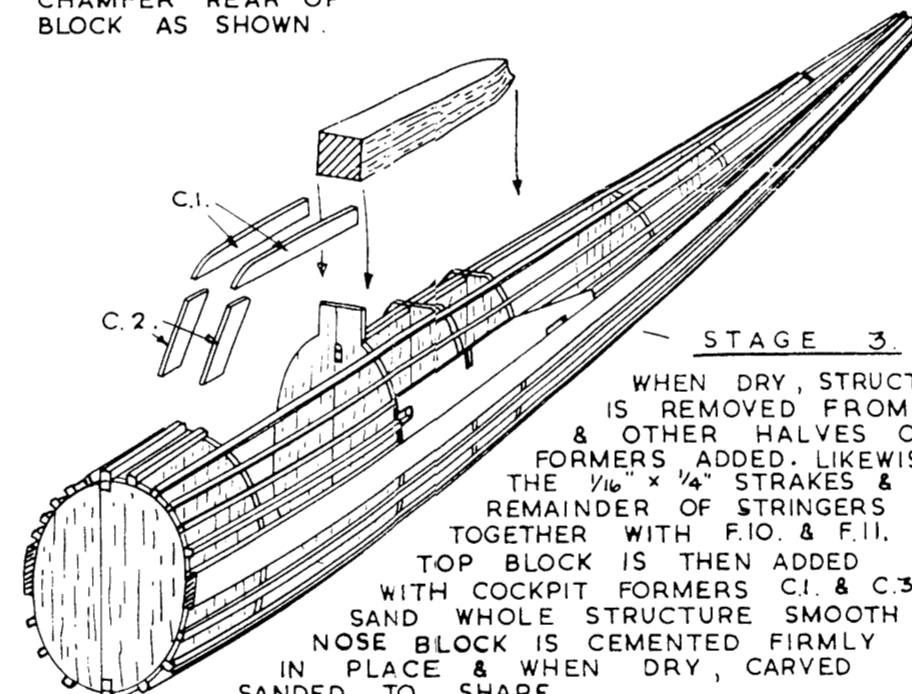

WHEN SLOT HAS BEEN CUT IN F.9, SLIDE COMPLETE TAIL IN PLACE & CEMENT FIRMLY ENSURING THAT IT IS FLAT TO FIT & SQUARE TO THE MODEL.

SKETCH BELOW SHOWS TAIL DIHEDRAL TEMPLATE IN USE. CUT OUT & PASTE TO THIN PIECE OF CARD ENSURE THAT JOINT BETWEEN TWO HALVES IS A CLOSE FIT & VERY FIRMLY CEMENTED.

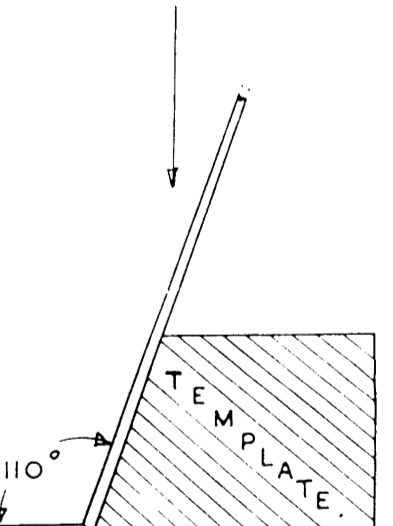
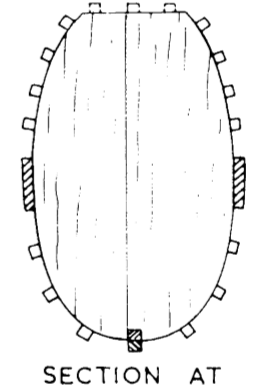

LEADING EDGE IS 1/8" x 1/8" SET SQUARE.

W/TIP DIHEDRAL (FROM C/SECTION) IS 2 1/2"

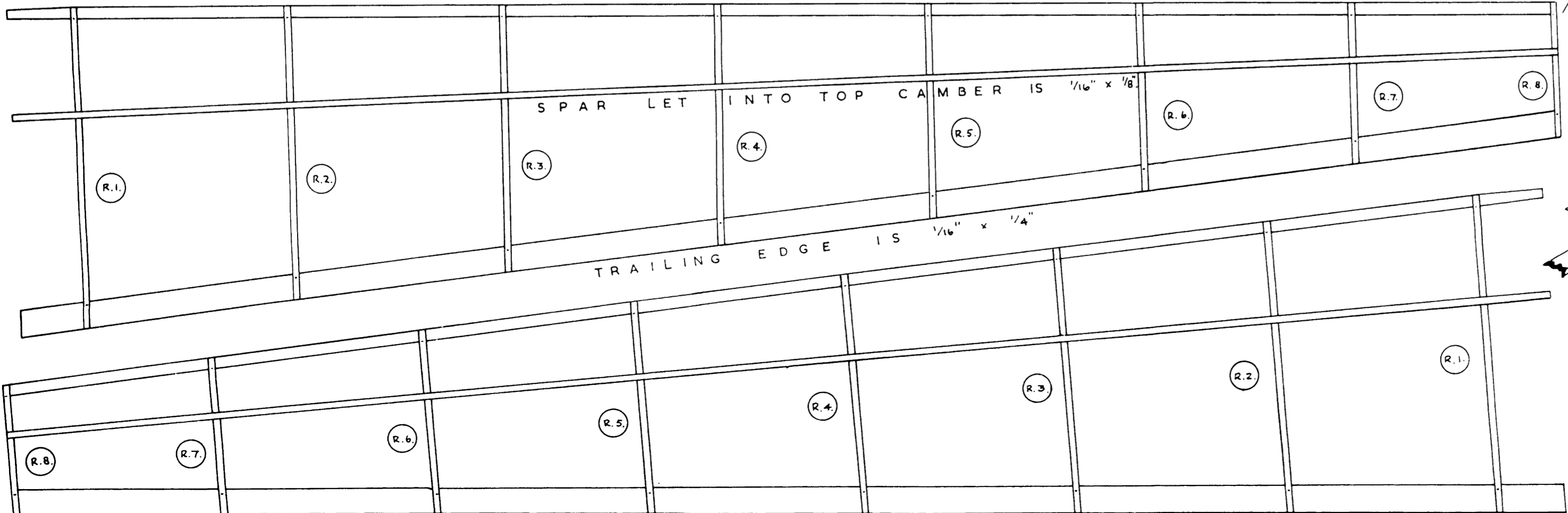

TOP SPAR.

SLOTTED T/EDGE.

L/EDGE.

1/16" SLOTS.

SKETCH BELOW SHOWS HOW WING ROOTS ARE OFFERED UP TO F.10'S. CEMENT SPAR & L/EDGE FIRMLY AGAINST F.3 & F.4.

SKETCH ABOVE SHOWS METHOD OF ASSEMBLY OF WING. L. & T/EDGES ARE LAID FIRST.

DESIGNED, DRAWN & TRACED BY P. L. SMITH. JAN. 1950 - COPYRIGHT RESERVED.

MANUFACTURED BY MODEL AIRCRAFT (BOURNEMOUTH) LTD.