

ASSEMBLY DRAWING

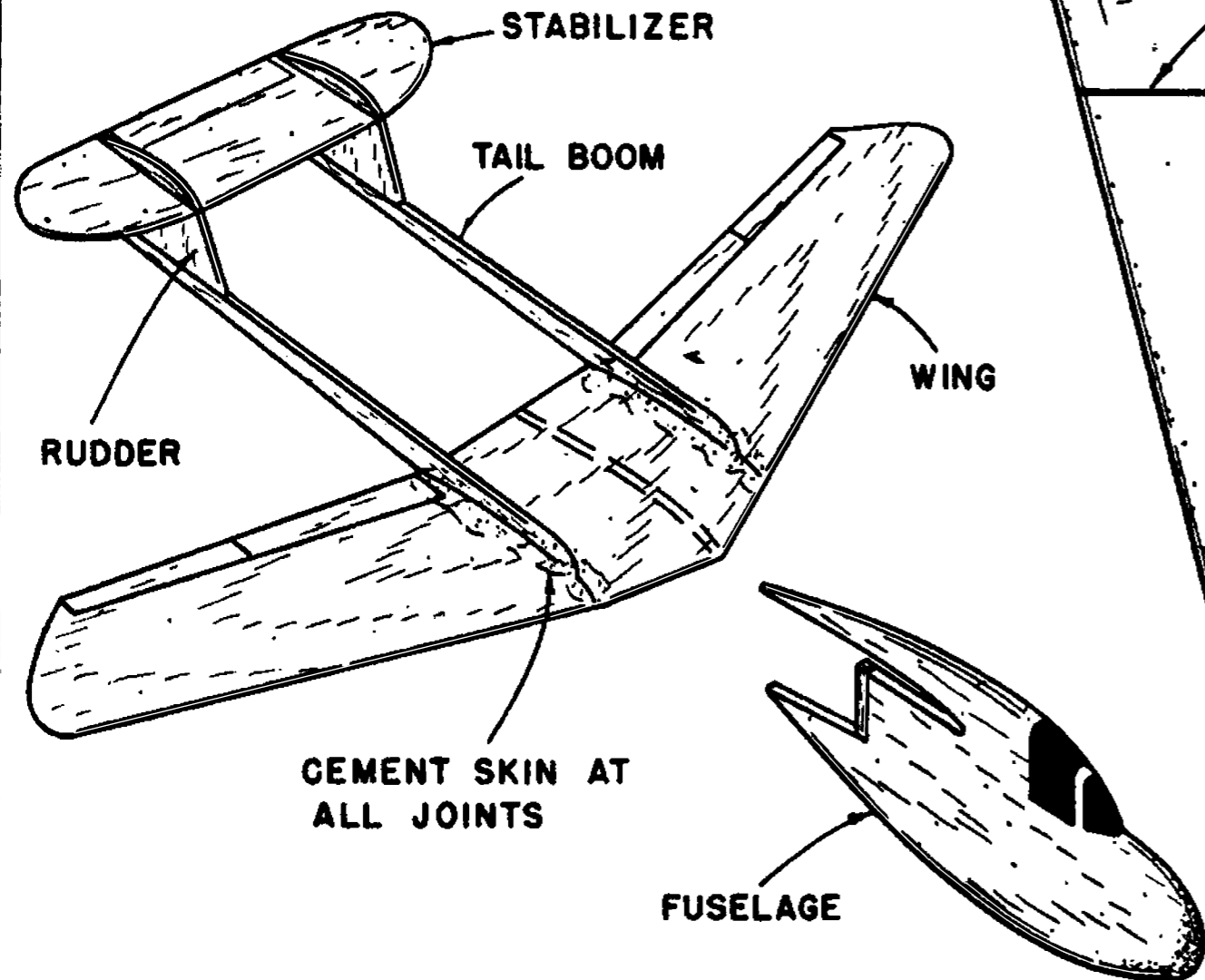

INDIA INK DETAILS

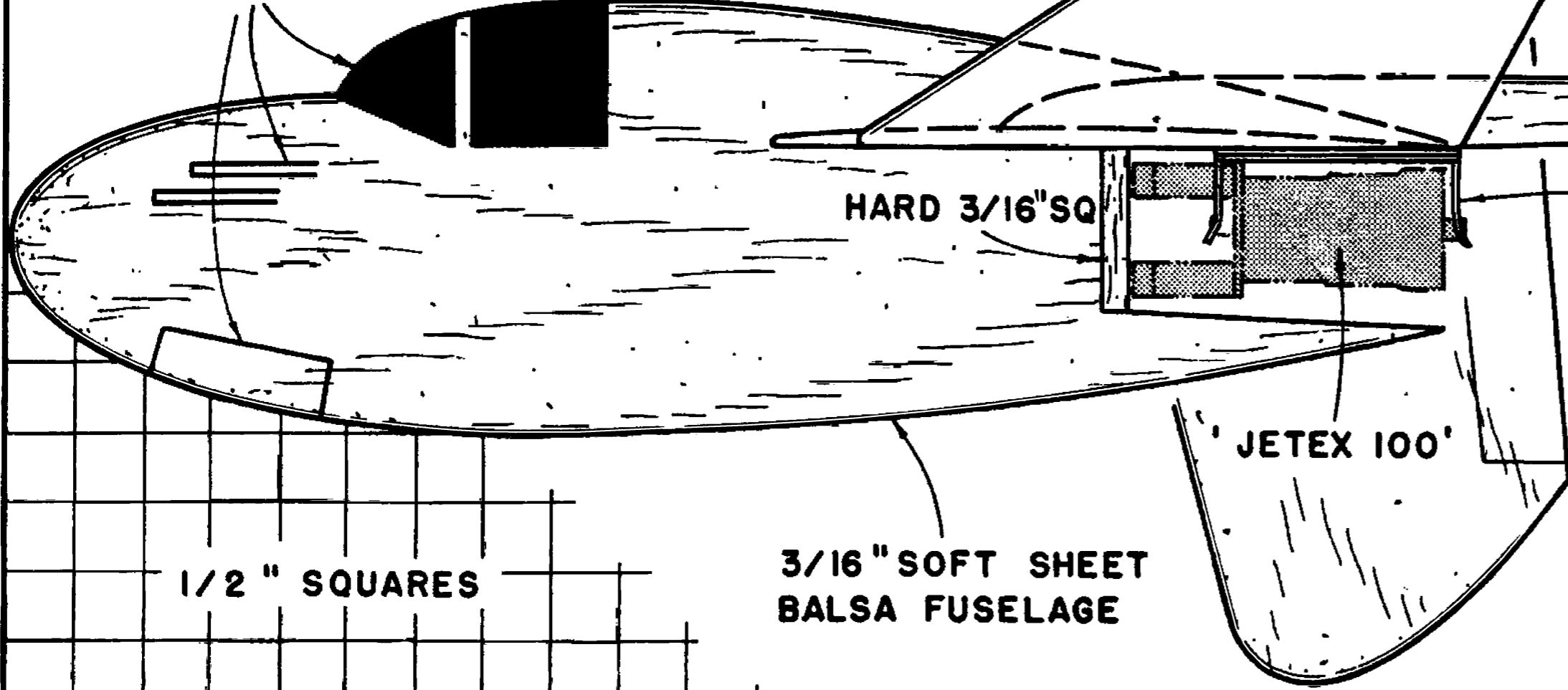

ASBESTOS SHEET ON BOTTOM FOR ENGINE MOUNT

DIHEDRAL BREAK

CENTER LINE

JIFFY JET

INDIA INK

TAIL BOOM

SOFT 1/16" SHEET Balsa STABILIZER

INDIA INK

1/8" SHEET Balsa WING. BUTT JOIN TO OBTAIN NECESSARY WIDTH.

1/16" SHEET RUDDER

TAIL BOOMS ARE CUT FROM HARD 1/8" X 1/2" TRAILING EDGE STOCK

FRONT VIEW

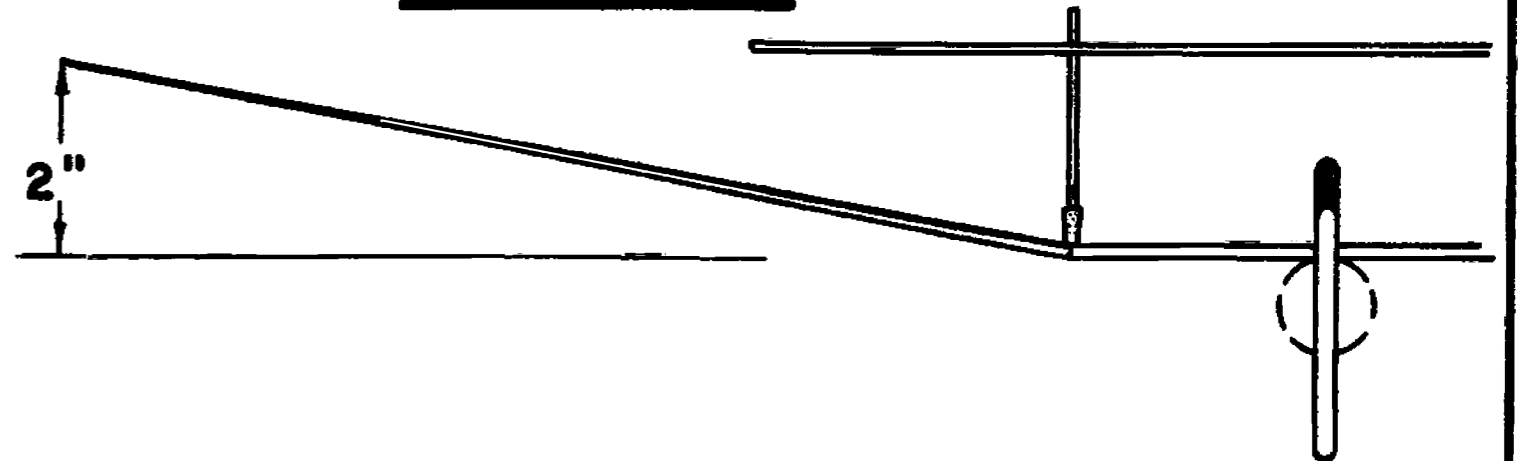

DICK STRUHL