

Begin by carefully cutting top (F15 & F16) and bottom (F17 & F18) longers from the printed wood sheet. Pin the longers down in their respective positions over shaded portion of plan. Cut all left half formers F19L to F20L from printed balsa sheet and cement these in place. Attach parts F19L and F20L. When dry, remove structure from plan.

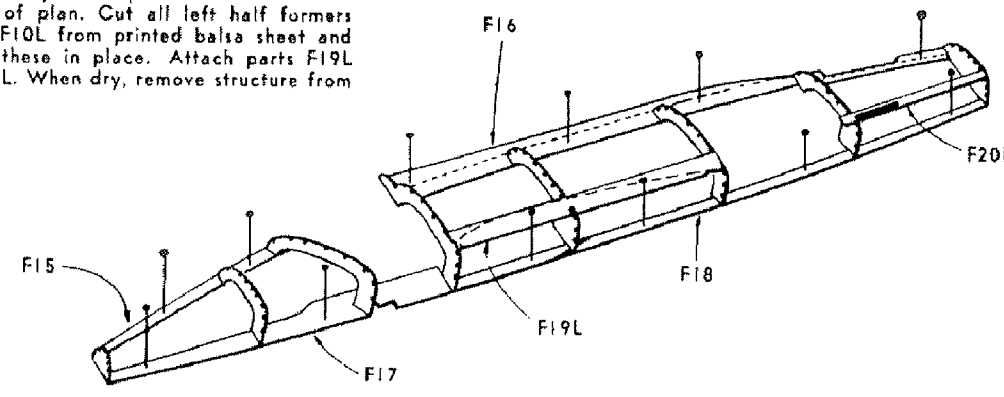

FUSELAGE CONSTRUCTION

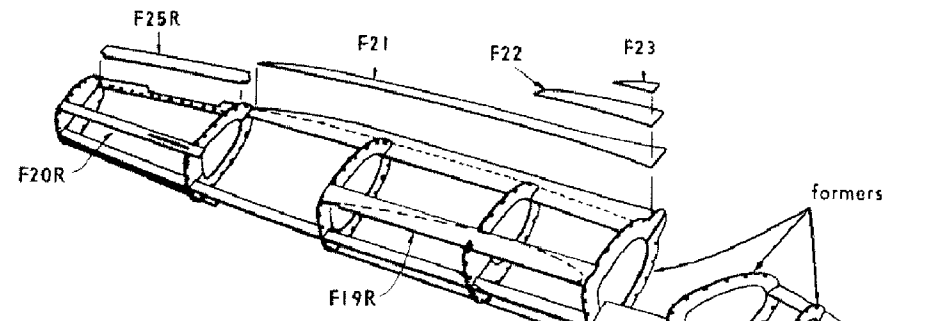

Cement corresponding right half formers F31R to F100R to structure. Follow with parts F19R and F20R. Attach fuselage fairing parts F21, F22, F23 (left & right) and F25L, F25R to framework.

Cement stringers into notches next. Do this in pairs—one on each side—to prevent fuselage from springing out of line. Cement part L2 to L1 for nose gear socket. Bevel edge of L1 to fit against former F5 and cement in place. Attach cockpit fairing F24 in position between formers F3 and F4. Cement nose intake formers F1 to F2 and attach to front of fuselage. Cement tail rings F11 to F14 together and attach to rear of fuselage. When dry, trim excess balsa from nose and tail rings and cockpit, fuselage fairings—then sandpaper entire fuselage framework.

WING CONSTRUCTION

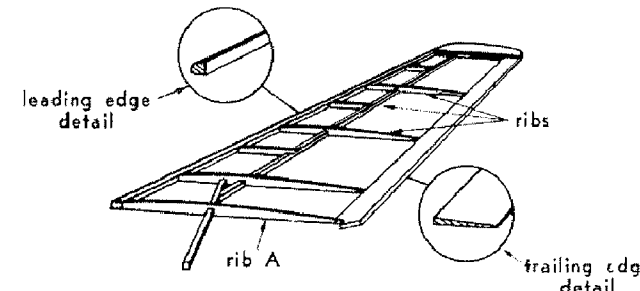
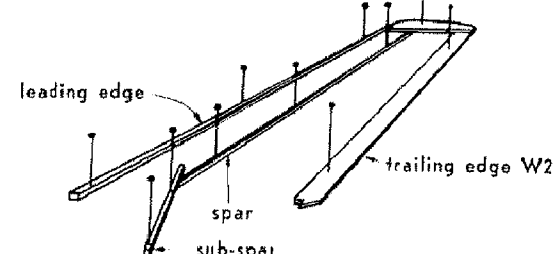

Build wing directly over plan. A sheet of wax paper will prevent cement from sticking to plan. Begin by pinning down leading edge, spar, sub-spar and trailing edge W2 in their respective positions over plan. Cement wing tip W1 in place.

Cut wing ribs A to H from printed sheet balsa. Cement these in place after carefully trimming ends to fit snugly between leading and trailing edges. When framework is dry, remove from plan and sandpaper leading and trailing edges as shown in detail, then trim and round off wing tips.

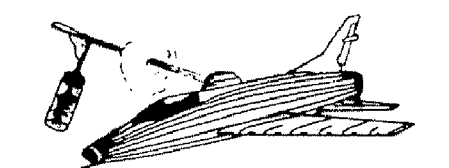

Stick tissue to framework using clear dope. Fibers of tissue should run the length of part being covered. Use narrow strips for covering fuselage. Attach strips between stringers. After all parts of model have been covered, cement them together and spray lightly with water. This shrinks the tissue sooth. A few coats of clear dope may be applied to keep tissue taut.

TISSUE COVERING

ASSEMBLY

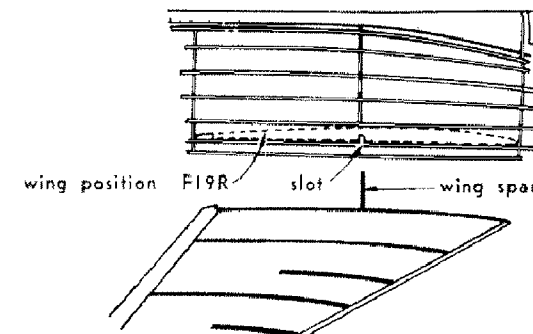

Cement rudder parts together over a flat surface and let dry thoroughly. Sandpaper rudder and stabilizer surfaces smooth and round edges slightly. Cement rudder fairing parts R3R, R3L and R4 in place and trim edges round. Brush one coat of clear dope onto all tail parts. Attach these to model after fuselage has been covered.

After fuselage and wings have been covered, cement wings to fuselage by applying cement along base rib A and into slot for wing spar. Slide wing carefully into position indicated by dash lines on parts F19. Next, attach tail parts to model.

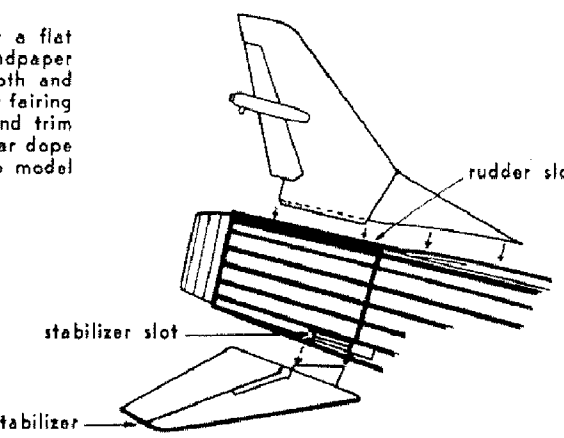

When model has been assembled minus landing gear, give the clear doped tissue two or three coats of Comet silver dope. Make and paint pitot tube, canopy trim and wheel hubs silver and cement carefully in position. Cut out all insignia and markings and attach to model with clear dope.

Make nose gear and left and right main gear struts from dowel furnished in kit and from instructions below. Cement landing gear cover door parts L7 & L5L neatly into their relative positions shown in side and front views. When dry, paint all landing gear strut assemblies silver. Paint wheels black and attach silver hubs. When dry, cement hubs to wheels, then slide onto axles. Apply a drop of cement for wheel stop. Cement landing gear units securely in place and allow to dry. Cement sub doors L6L as shown in side and front views.

TETHER FLYING

Be sure that the tether line guide hook and anchor hook are made to size shown on plan and are securely fastened to the model. These must be placed in their required positions to give the model its proper balance in flight. Fishing line or string may be used for the tether line and must be secured to a pole about five to ten feet in length. While learning to get the "feel" of the model it is best that you use one pole length of line. With a little practice you can climb or dive the plane by raising or lowering the pole. Use a longer line to step up the fun when you have become familiar with the model. Take-offs can be made by shortening the line and paying it out when the model is in the air. Landings will require a smooth surface. While flying, always remember that the model will tend to follow the tip of the pole.

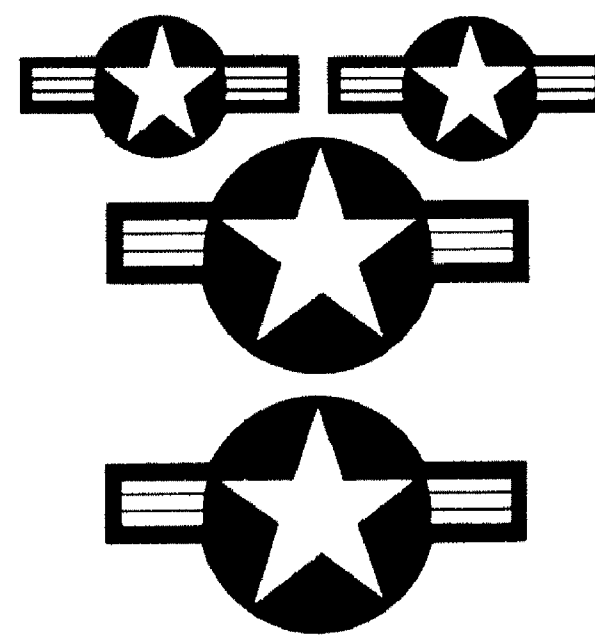
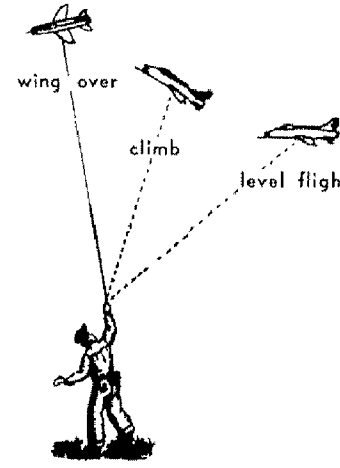

**FW-766**  
**FW-766**

US AIR FORCE 25766 US AIR FORCE 25766



ATTACH BETWEEN FORMERS F 4-F 5

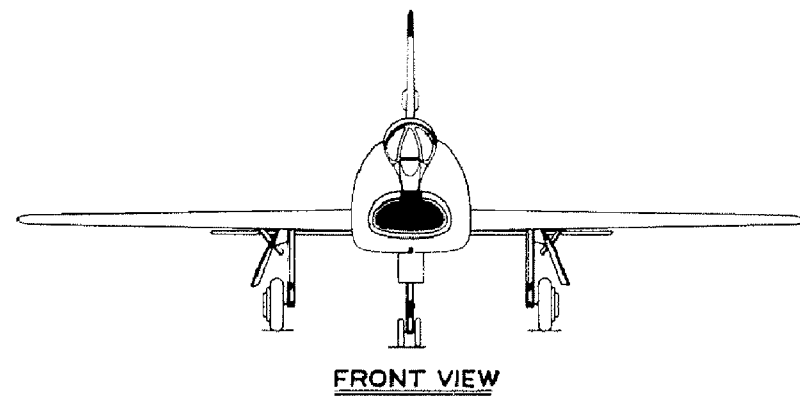

FRONT VIEW

CUT INSIGNIA AND MARKINGS FROM PLAN AND ATTACH TO MODEL AFTER IT HAS BEEN COMPLETED AND DOPED.

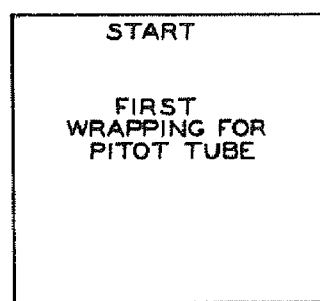

START

FIRST WRAPPING FOR PITOT TUBE

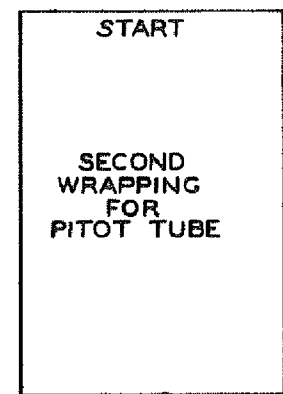

START

SECOND WRAPPING FOR PITOT TUBE

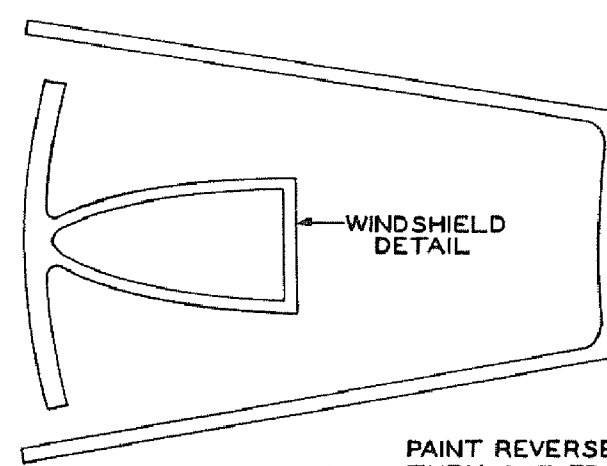

CANOPY TRIM

PAINT REVERSE SIDE OF PRINT SILVER THEN CUT FROM PRINT AND ATTACH TO PLASTIC CANOPY

**USAF**  
**USAF**

CUT PITOT WRAPPINGS FROM PLAN AND MAKE TUBE AS SHOWN BELOW



PITOT TUBE FAIRING

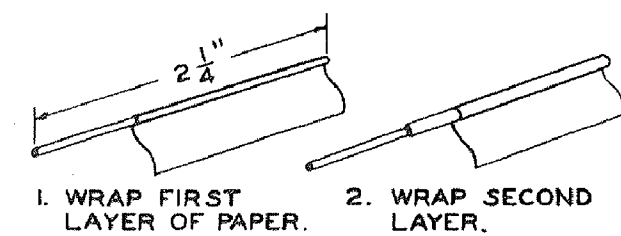

1. WRAP FIRST LAYER OF PAPER. 2. WRAP SECOND LAYER.

3. CUT END TO ANGLE SHOWN ON PLAN. APPLY CEMENT TO TRIMMED END TO PREVENT UNRAVELLING.

PITOT TUBE DETAIL

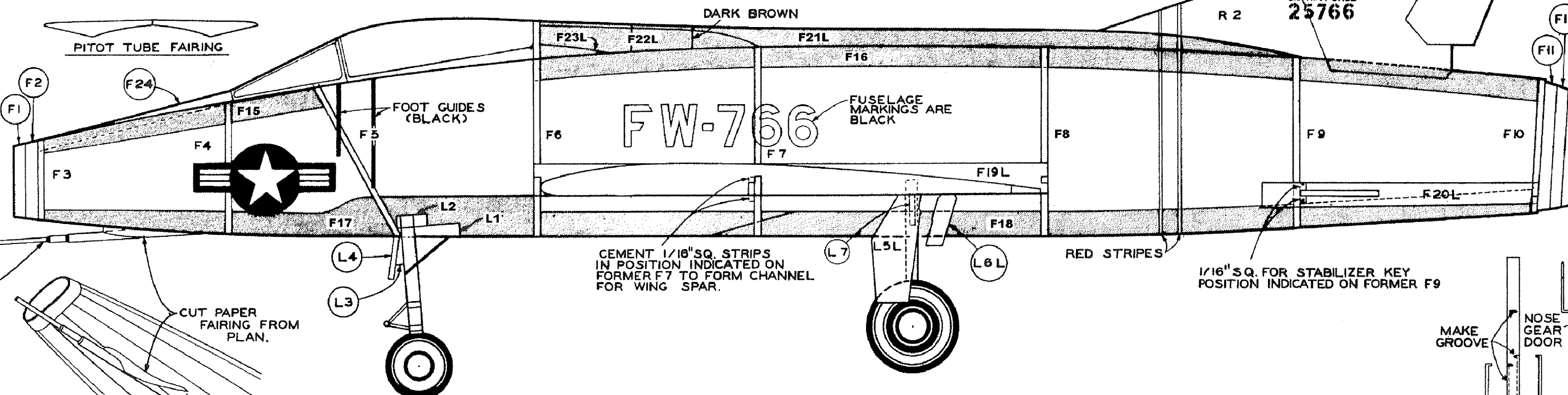

FOOT GUIDES (BLACK)

FUSELAGE MARKINGS ARE BLACK

RED STRIPES

1/16" SQ. STRIPS IN POSITION INDICATED ON FORMER F7 TO FORM CHANNEL FOR WING SPAR.

1/16" SQ. FOR STABILIZER KEY POSITION INDICATED ON FORMER F9

WIRE AXLE

NOSE GEAR DETAIL

MAIN GEAR DETAIL

WIRE AXLE

WHEEL HUB H1 & H2

CEMENT STOP

THREAD BINDING

WIRE AXLE

CEMENT STOP

WIRE AXLE

WHEEL HUB H1 & H2

CEMENT STOP

THREAD BINDING

WIRE AXLE

WHEEL HUB H1 & H2

CEMENT STOP

THREAD BINDING

WIRE AXLE

WHEEL HUB H1 & H2

CEMENT STOP

THREAD BINDING

WIRE AXLE

WHEEL HUB H1 & H2

CEMENT STOP

THREAD BINDING

WIRE AXLE

WHEEL HUB H1 & H2

CEMENT STOP

THREAD BINDING

WIRE AXLE

WHEEL HUB H1 & H2

CEMENT STOP

THREAD BINDING

WIRE AXLE

WHEEL HUB H1 & H2

CEMENT STOP

THREAD BINDING

WIRE AXLE

WHEEL HUB H1 & H2

CEMENT STOP

THREAD BINDING

WIRE AXLE

WHEEL HUB H1 & H2

CEMENT STOP

THREAD BINDING

WIRE AXLE

WHEEL HUB H1 & H2

CEMENT STOP

THREAD BINDING

WIRE AXLE

WHEEL HUB H1 & H2

CEMENT STOP

THREAD BINDING

WIRE AXLE

WHEEL HUB H1 & H2

CEMENT STOP

THREAD BINDING

WIRE AXLE

WHEEL HUB H1 & H2

CEMENT STOP

THREAD BINDING

WIRE AXLE

WHEEL HUB H1 & H2

CEMENT STOP

THREAD BINDING

WIRE AXLE

WHEEL HUB H1 & H2

CEMENT STOP

THREAD BINDING

WIRE AXLE

WHEEL HUB H1 & H2

CEMENT STOP

THREAD BINDING

WIRE AXLE

WHEEL HUB H1 & H2

CEMENT STOP

THREAD BINDING

WIRE AXLE

WHEEL HUB H1 & H2

CEMENT STOP

THREAD BINDING

WIRE AXLE

WHEEL HUB H1 & H2

CEMENT STOP

THREAD BINDING

WIRE AXLE

WHEEL HUB H1 & H2

CEMENT STOP

THREAD BINDING

WIRE AXLE

WHEEL HUB H1 & H2

CEMENT STOP

THREAD BINDING

WIRE AXLE

WHEEL HUB H1 & H2

CEMENT STOP

THREAD BINDING

WIRE AXLE

WHEEL HUB H1 & H2

CEMENT STOP

THREAD BINDING

WIRE AXLE

WHEEL HUB H1 & H2

CEMENT STOP

THREAD BINDING

WIRE AXLE

WHEEL HUB H1 & H2

CEMENT STOP

THREAD BINDING

WIRE AXLE

WHEEL HUB H1 & H2

CEMENT STOP

THREAD BINDING

WIRE AXLE

WHEEL HUB H1 & H2

CEMENT STOP

THREAD BINDING

WIRE AXLE

WHEEL HUB H1 & H2

CEMENT STOP

THREAD BINDING

WIRE AXLE

WHEEL HUB H1 & H2

CEMENT STOP

THREAD BINDING

WIRE AXLE

WHEEL HUB H1 & H2

CEMENT STOP

THREAD BINDING

WIRE AXLE

WHEEL HUB H1 & H2

CEMENT STOP

THREAD BINDING

WIRE AXLE

WHEEL HUB H1 & H2

CEMENT STOP

THREAD BINDING

WIRE AXLE

WHEEL HUB H1 & H2

CEMENT STOP

THREAD BINDING

WIRE AXLE

WHEEL HUB H1 & H2

CEMENT STOP

THREAD BINDING

WIRE AXLE

WHEEL HUB H1 & H2

CEMENT STOP

THREAD BINDING

WIRE AXLE

WHEEL HUB H1 & H2

CEMENT STOP

THREAD BINDING

WIRE AXLE

WHEEL HUB H1 & H2

CEMENT STOP

THREAD BINDING

WIRE AXLE

WHEEL HUB H1 & H2

CEMENT STOP

THREAD BINDING

WIRE AXLE

WHEEL HUB H1 & H2

CEMENT STOP

THREAD BINDING

WIRE AXLE

WHEEL HUB H1 & H2

