

EXPERIMENTAL
FR

TRIDENT

SO-9.000

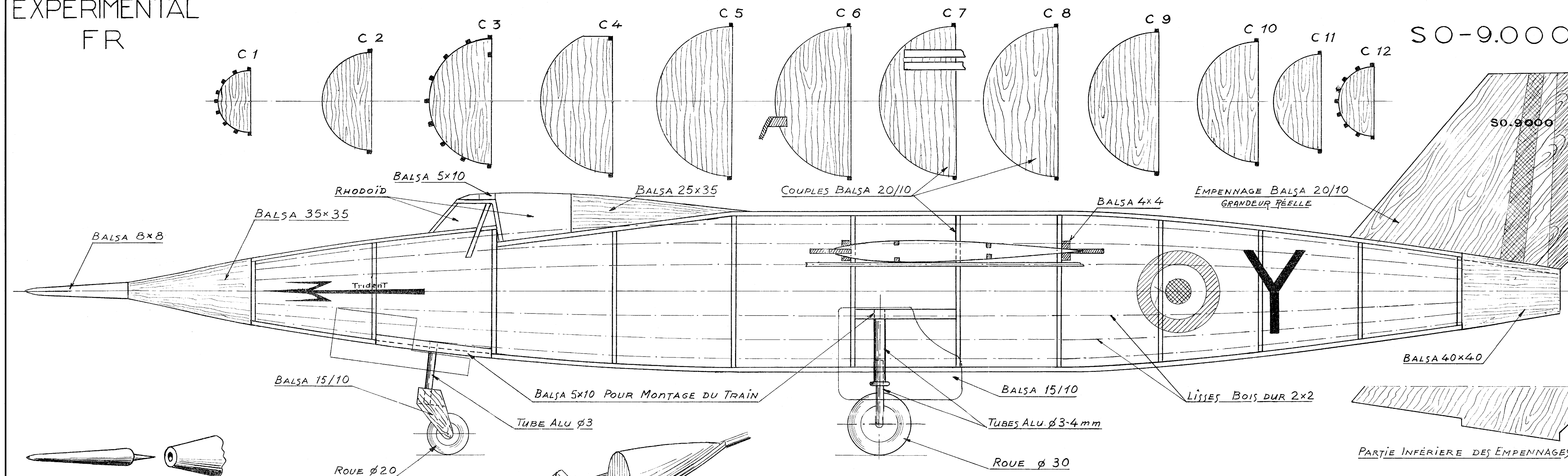
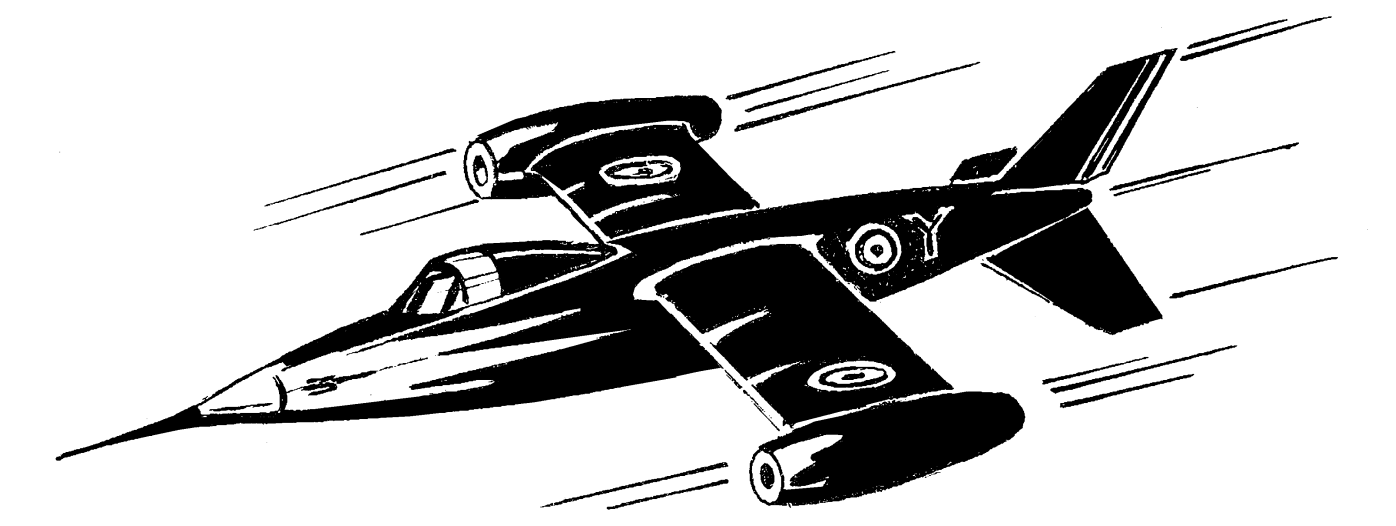

CARACTÉRISTIQUES

LONGUEUR	m	14
ENVERGURE	-	8.15
HAUTEUR	-	3.70
POIDS TOTAL	kgs	5.000
MOTEURS		
2 Turbomeca MARBORA de 400 kgp		
3 Fusées de 1250 kgp		
VITESSE	mach	1.6
PLAFOND	m	18.000

NOTA- CET APPAREIL PEUT ÊTRE EXÉCUTÉ EN FUSELAGE COQUE EN REMPLAÇANT LES LISSES 2x2 PAR DES BAGUETTES DE Balsa 2x5

