

1/8" SQ. BALSA L. E.

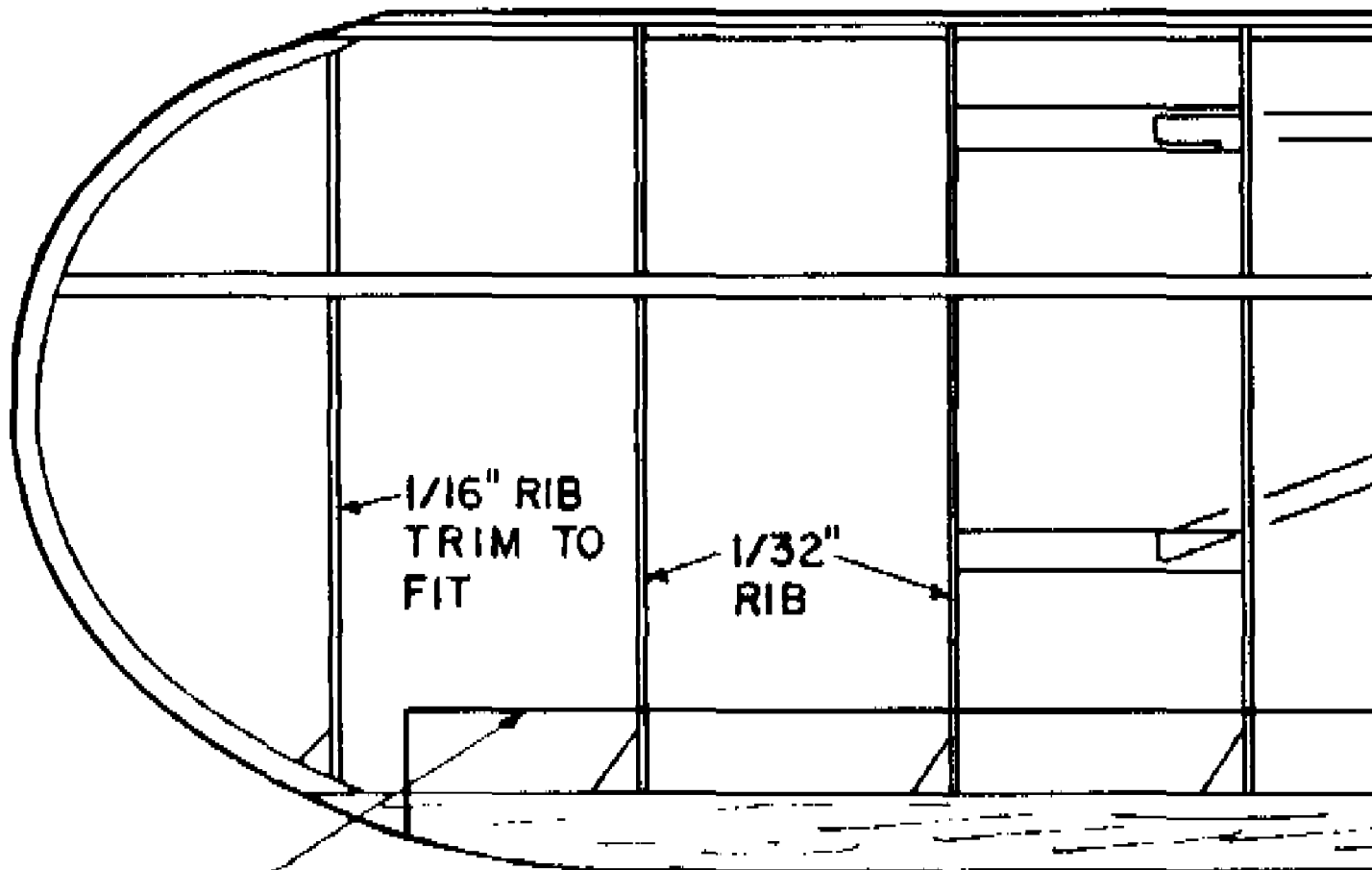

AILERON
OUTLINE

1/8" x 3/8" BALSA T. E.

1/16" DOWEL



WING RIB

10
4

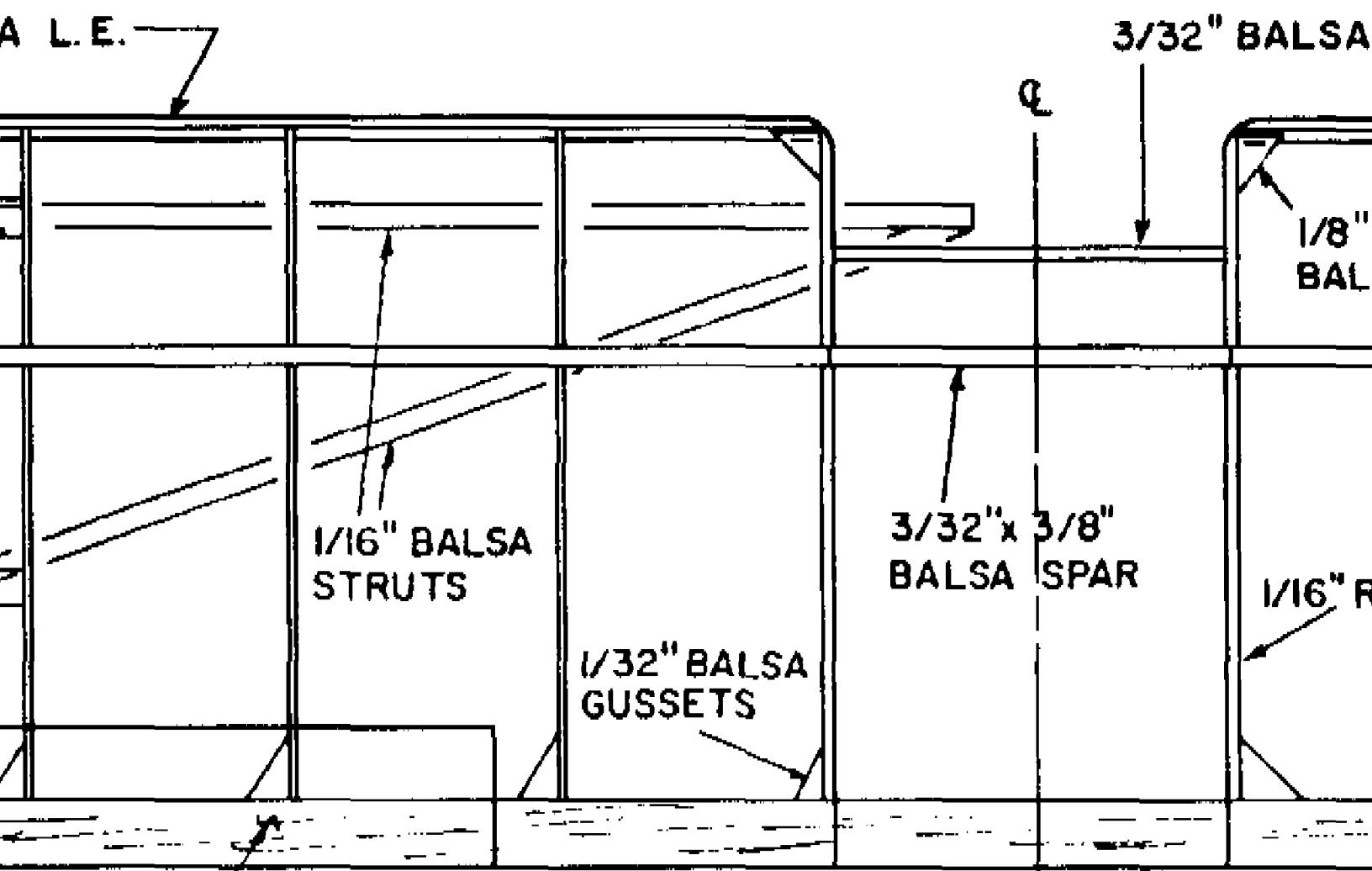

B 10 OF 1/32" BALS
4 OF 1/16" BALS



1/16" BALS
F-IT
1/16" BALS (2) → F-IS

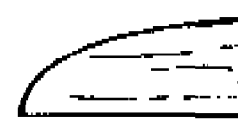

BALSA

WING PLAN

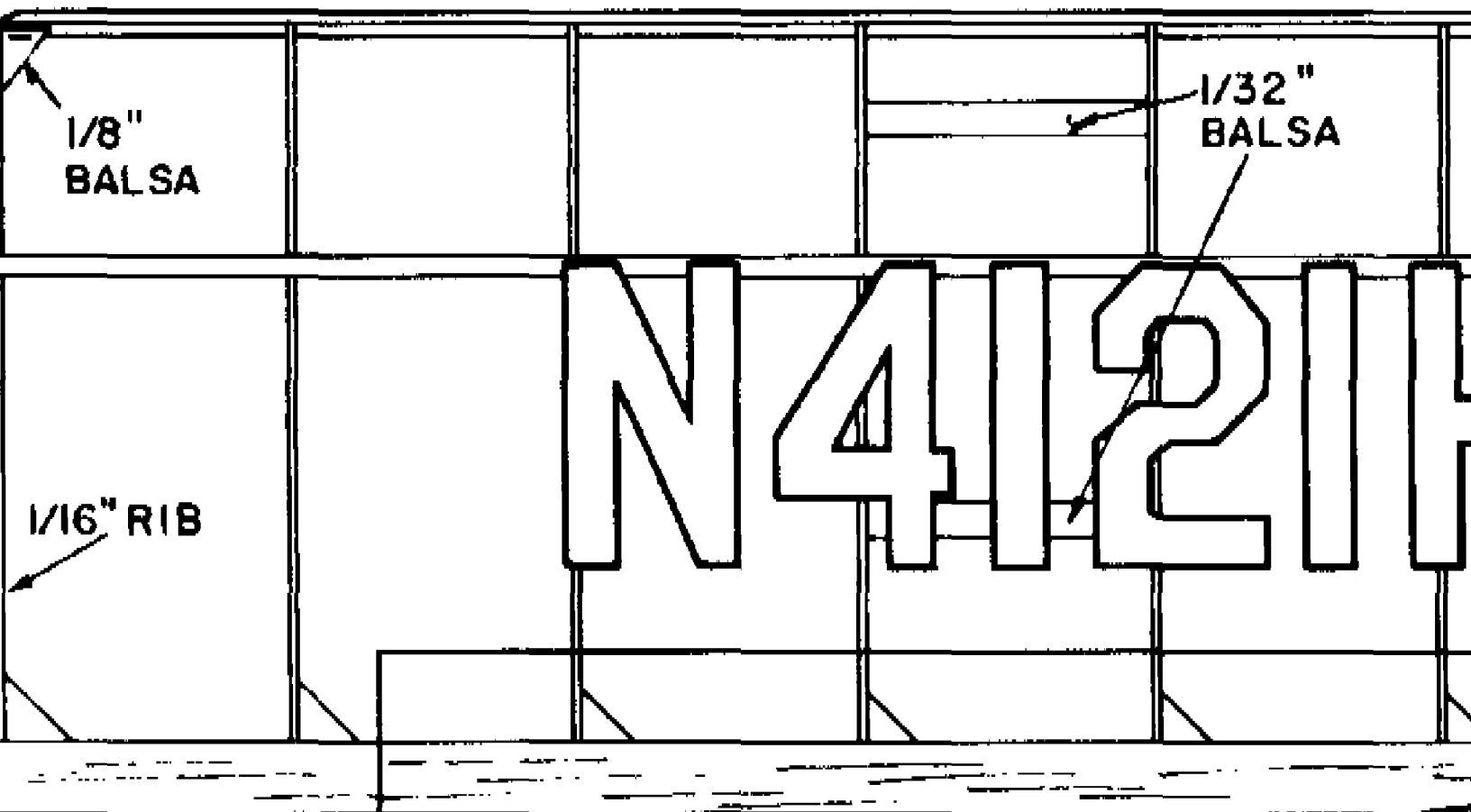

1/16" BALSA

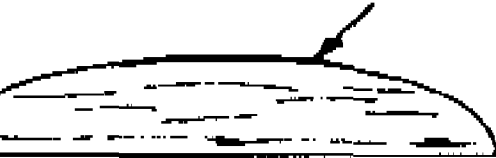

F-2



1/64" PLY

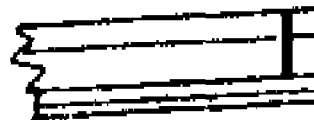

DIH

WING TIPS ARE 4 LAMS
OF $1/32'' \times 3/32''$ BALSA

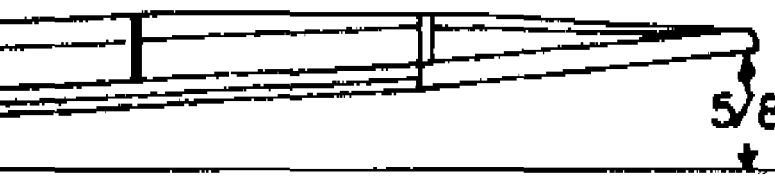
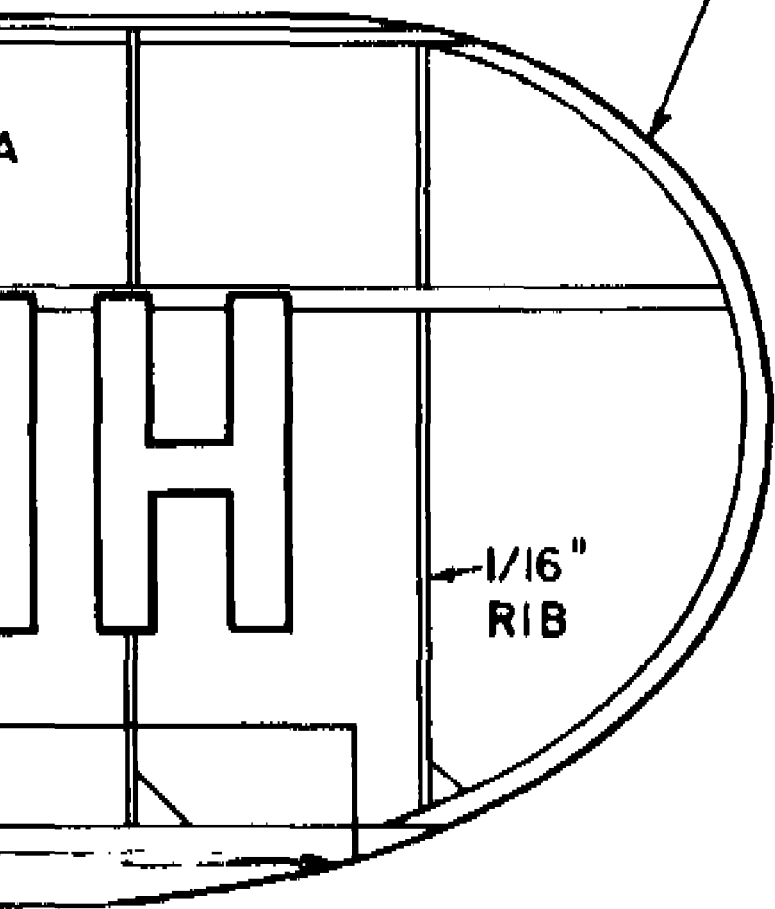

DIHEDRAL DETAIL

1/16" DOWEL

WING RIB

10
4

15* TEST LINE

1/8" BA

SHOCK
COVERS

WIRE INSULATION

FRONT VIEW

L.G. WIRE
FREE AT
BOTTOM

PECK
BUSHING

1/32" Balsa

1/64" PLY

F-1

E

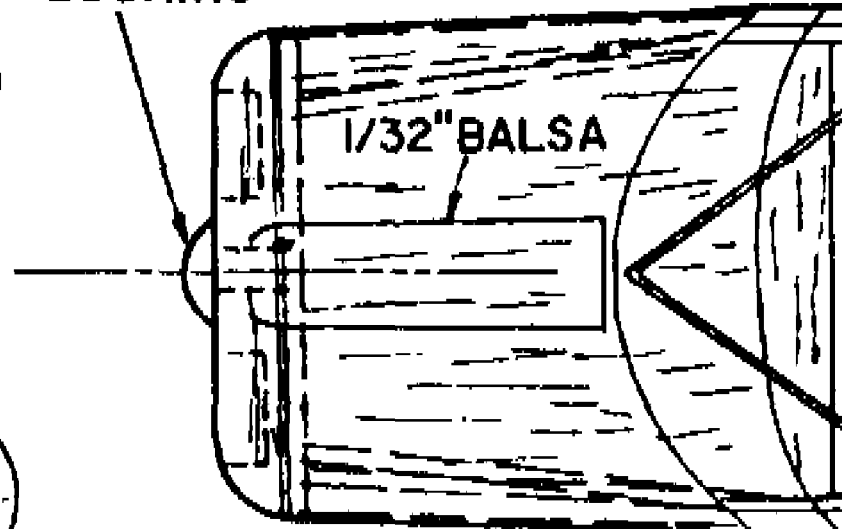
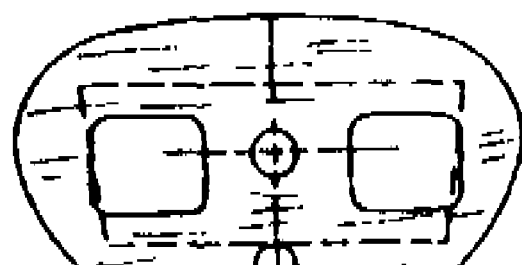
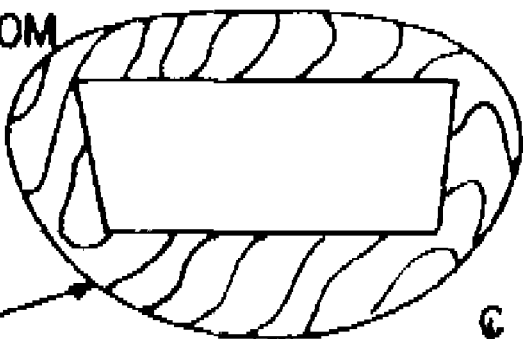
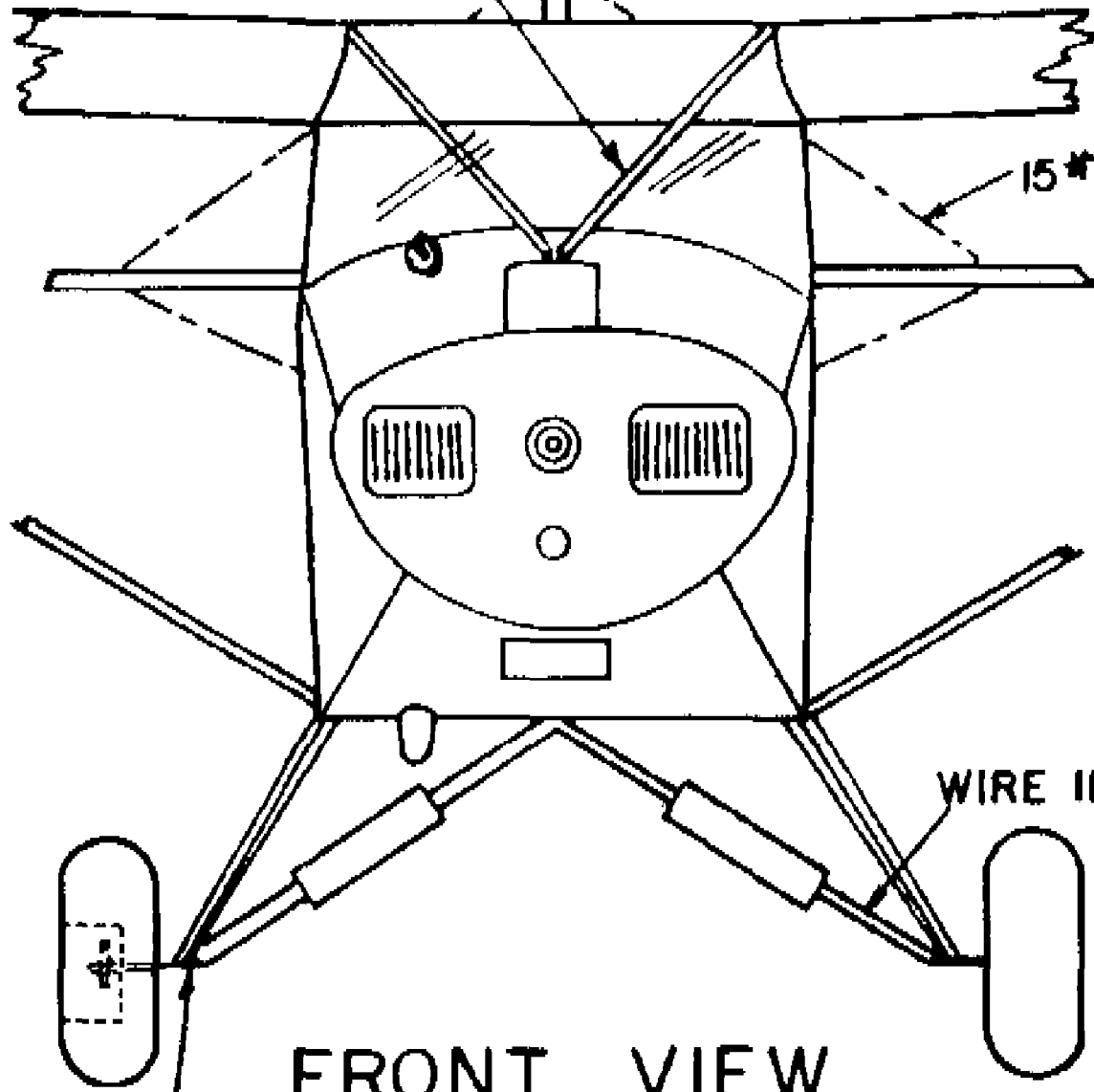

B 10 OF 1/32" Balsa
4 OF 1/16" Balsa

F-1T
1/16" Balsa (2) → F-IS

INSTRUM

LINE

1/8" Balsa

CK
ERS

TION

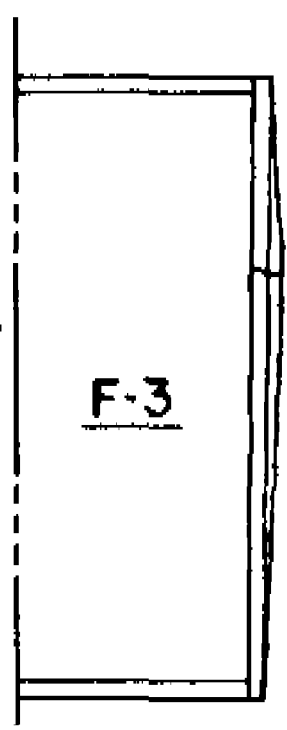

F-3

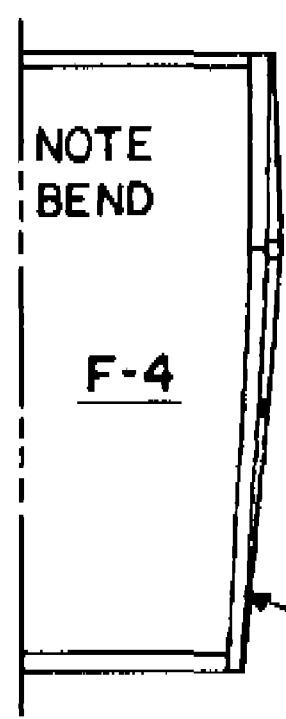

NOTE
BEND

F-4

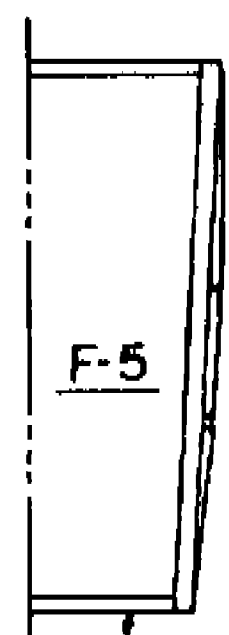

F-5

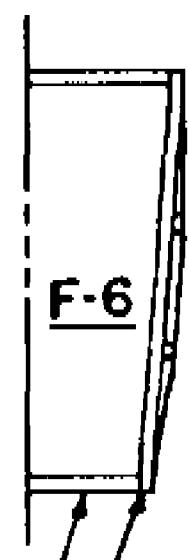

F-6

3/32" SQ. Balsa

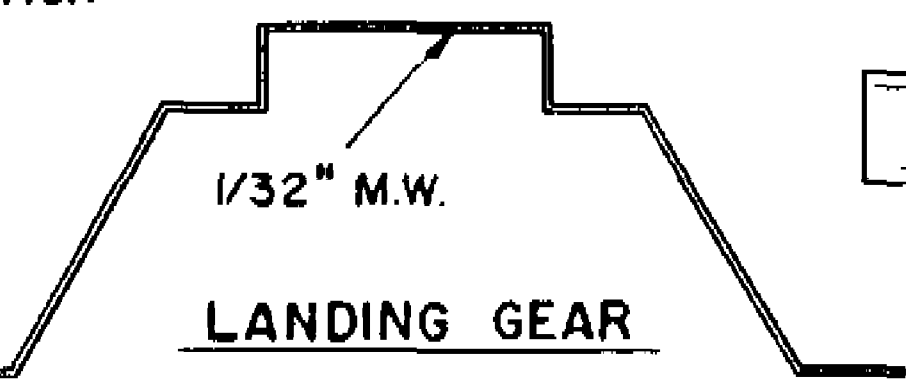

1/32" M.W.

LANDING GEAR

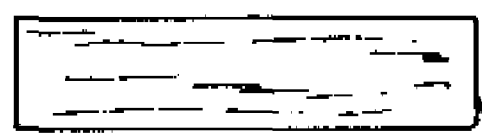

L. G. MOUNT

1/16" Balsa
(2)

L. G.

FUSELAGE TOP

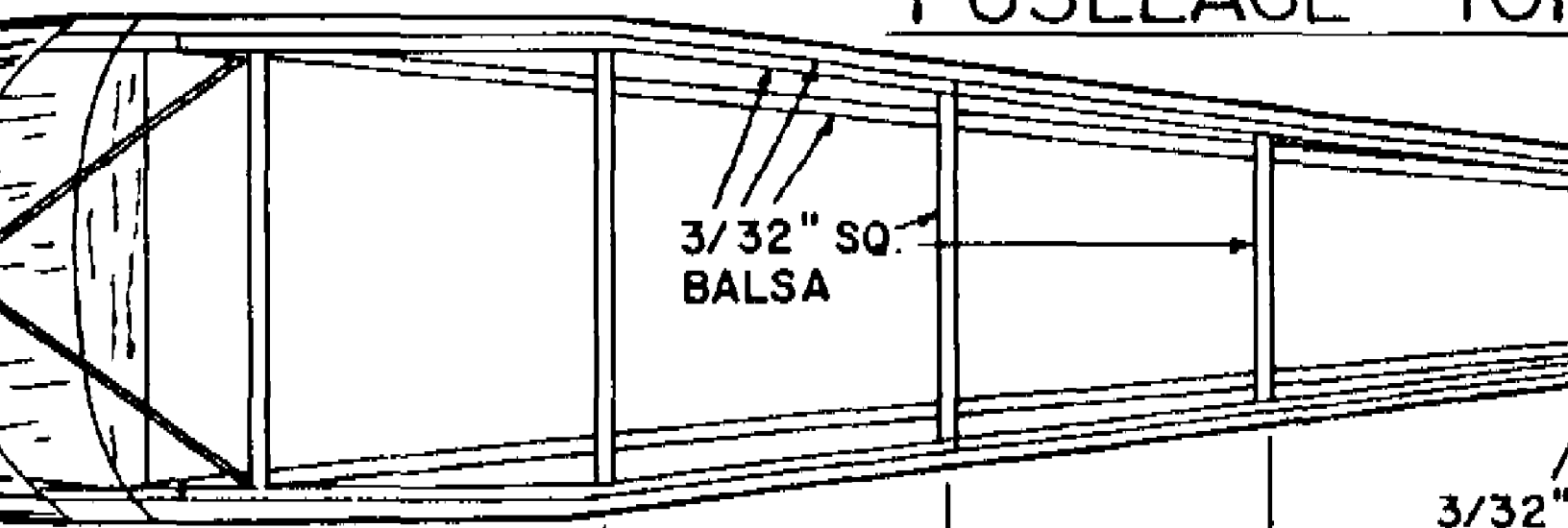

3/32" SQ. Balsa

3/32" ALUM.

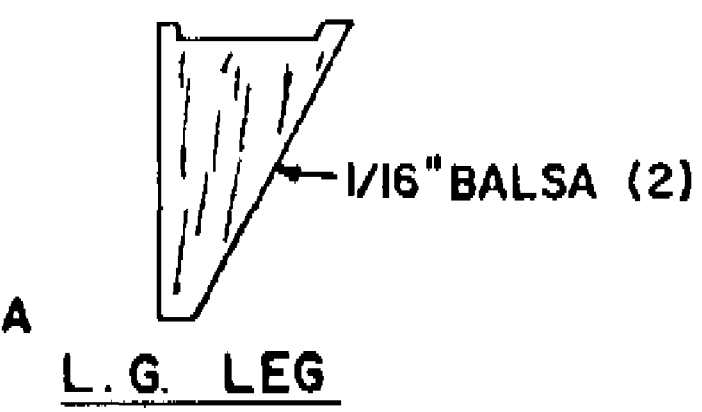
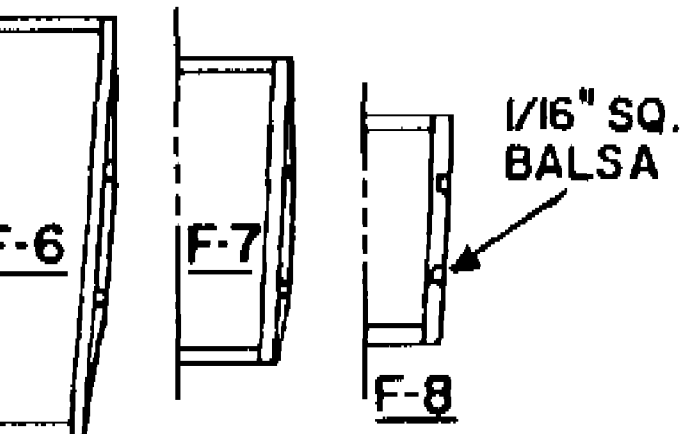
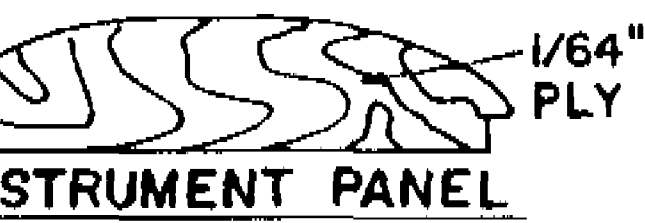

TOP VIEW

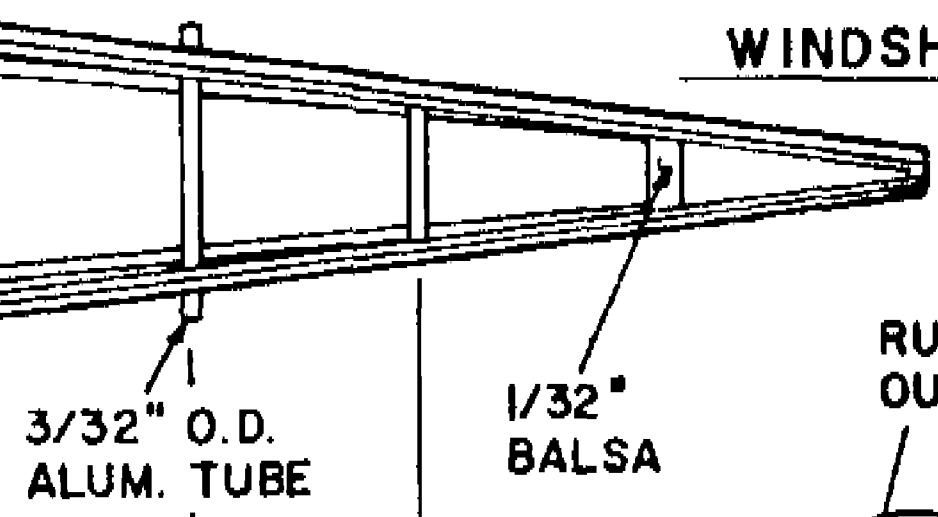
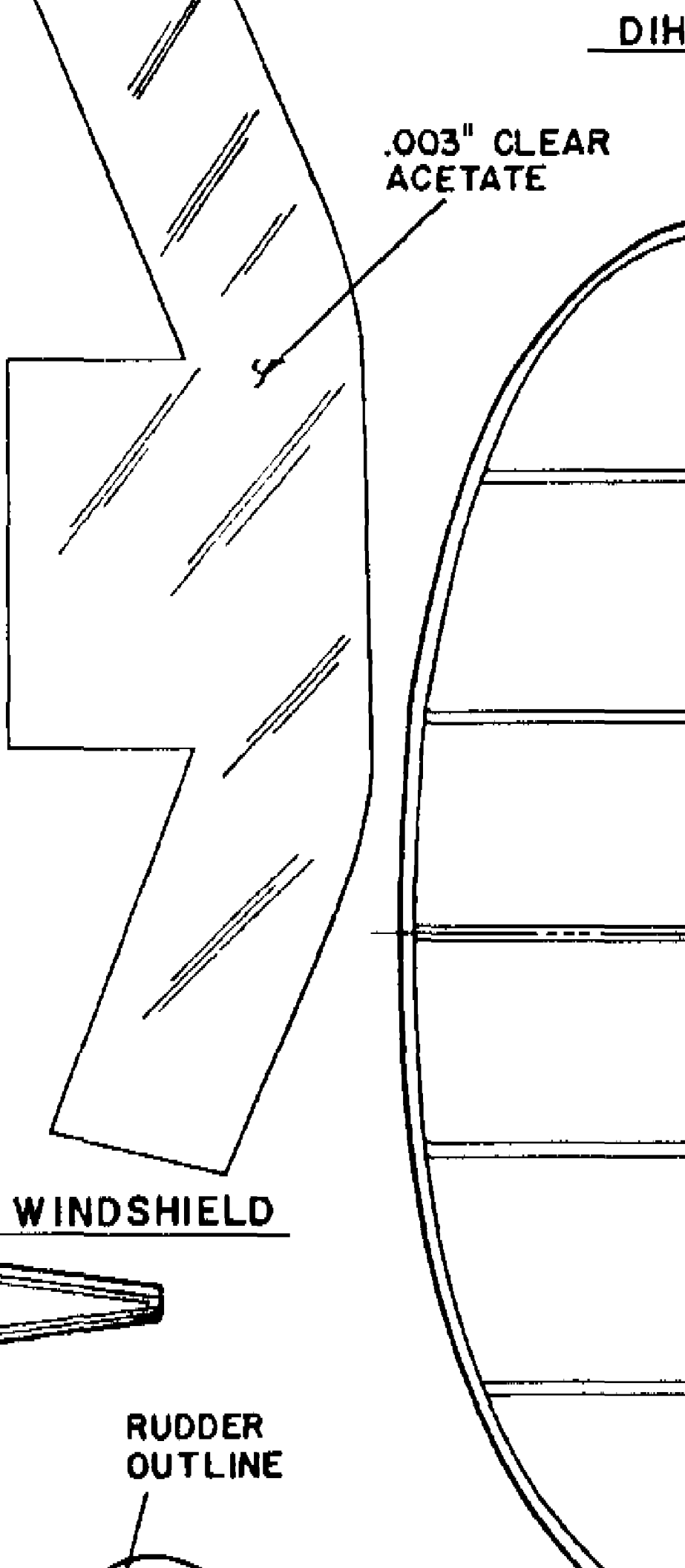

DIHEDRAL DETAIL

AR

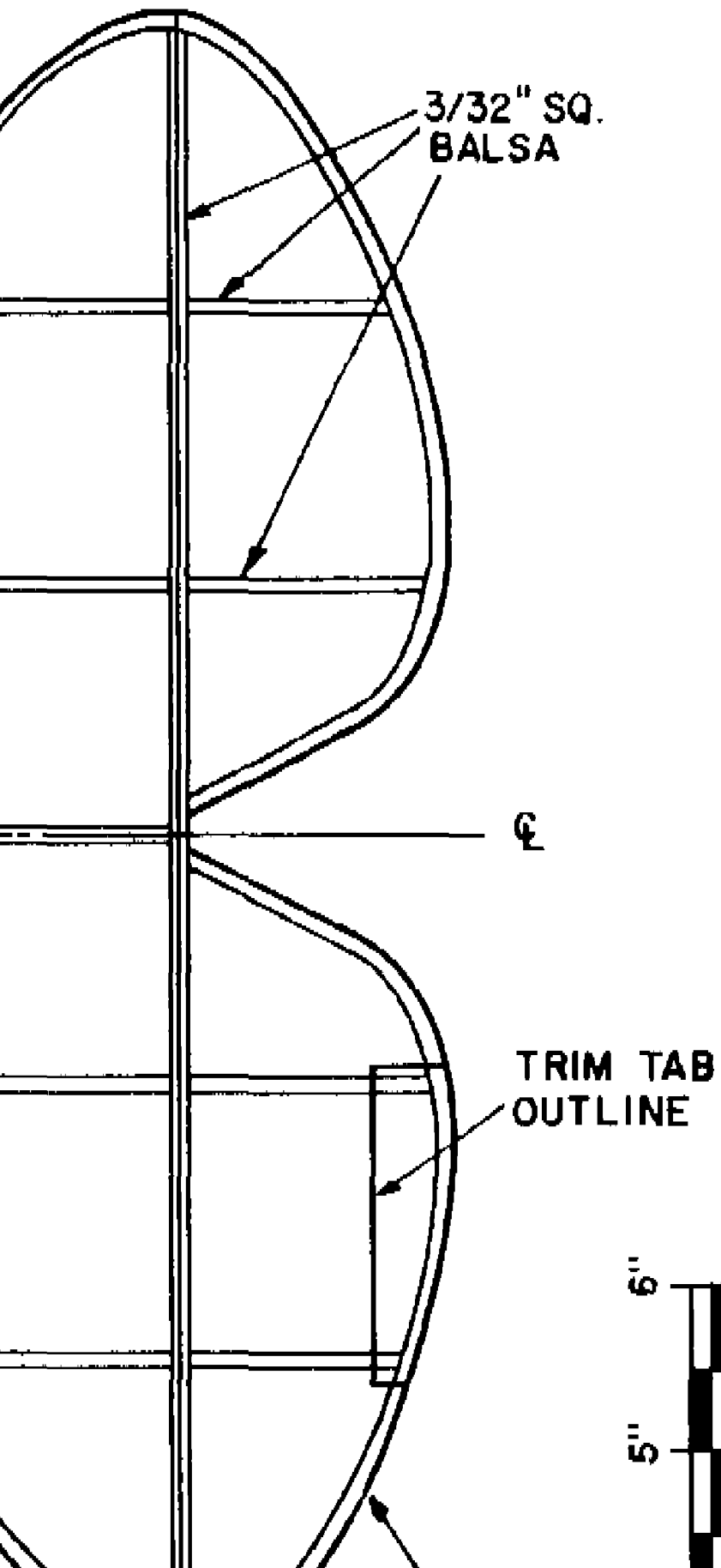

3/8" Balsa

NOSEBLOCK

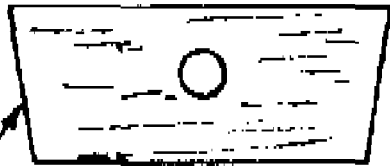

NOSE PLUG

3/16" Balsa

1/32" M.W. PROP SHAFT

8" PECK POLYMER PROPELLER

F-1

F-2

COVER TOP AND SIDES WITH 1/32" Balsa

HOLLOWED Balsa BLOCK

• 1 TREXLER AIR OR SHAPE FRO

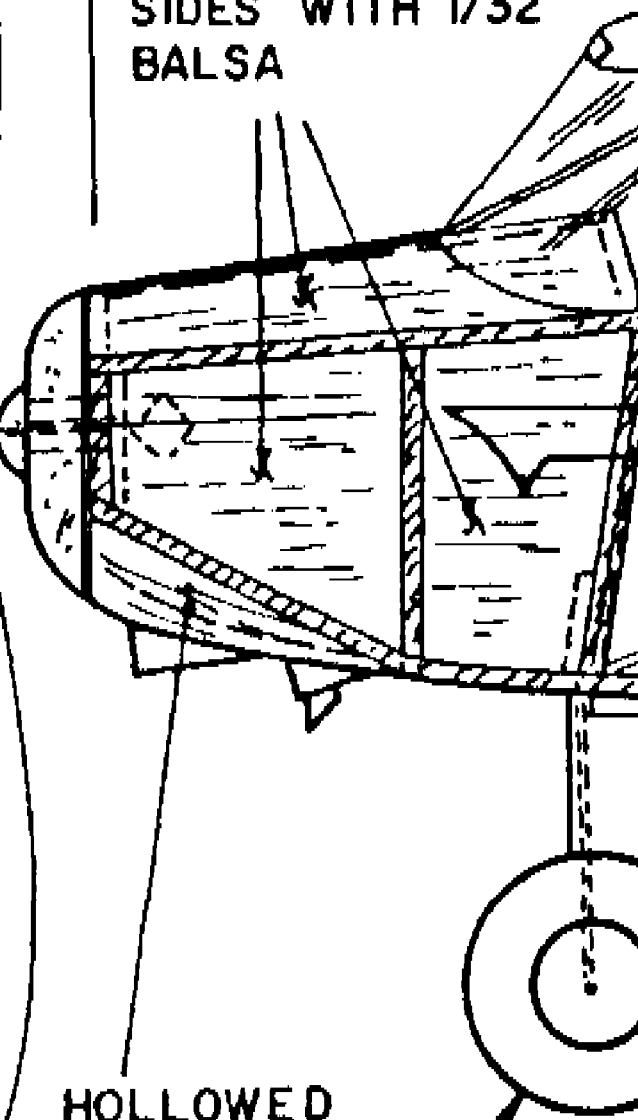
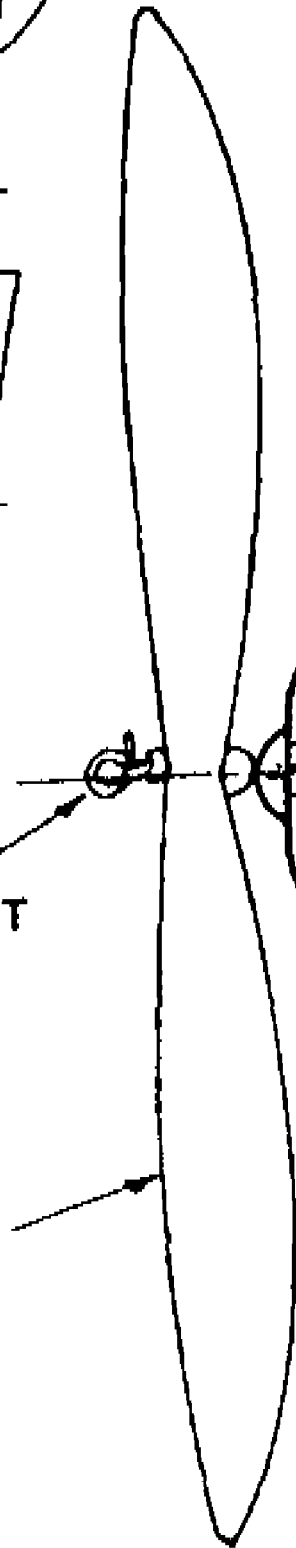
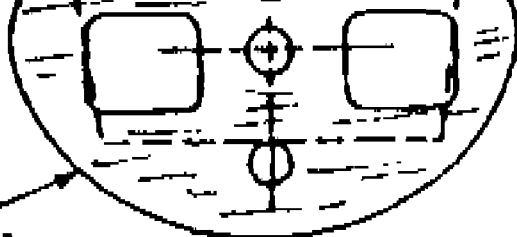

3/32"
ALUM.

F-2

F-3

F-4

F-5

F-6

F

D
3/32"

C.G.

1/16" SQ.
BALSA

FRAME IS 3/32"
SQ. BALSA

POWER
1/8"
BRAI

ER AIR WHEELS
E FROM FOAM

FUSELAGE SIDE VIEW

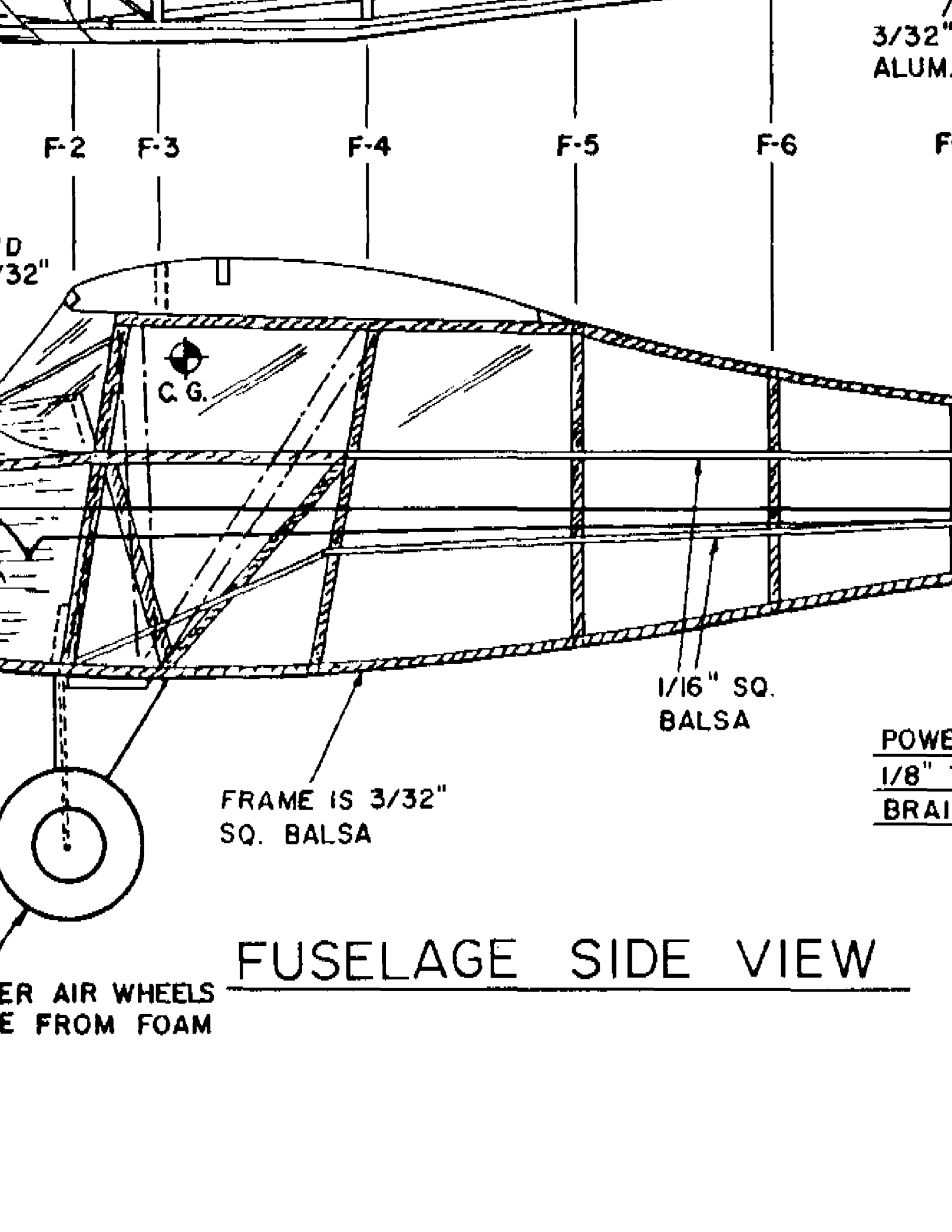

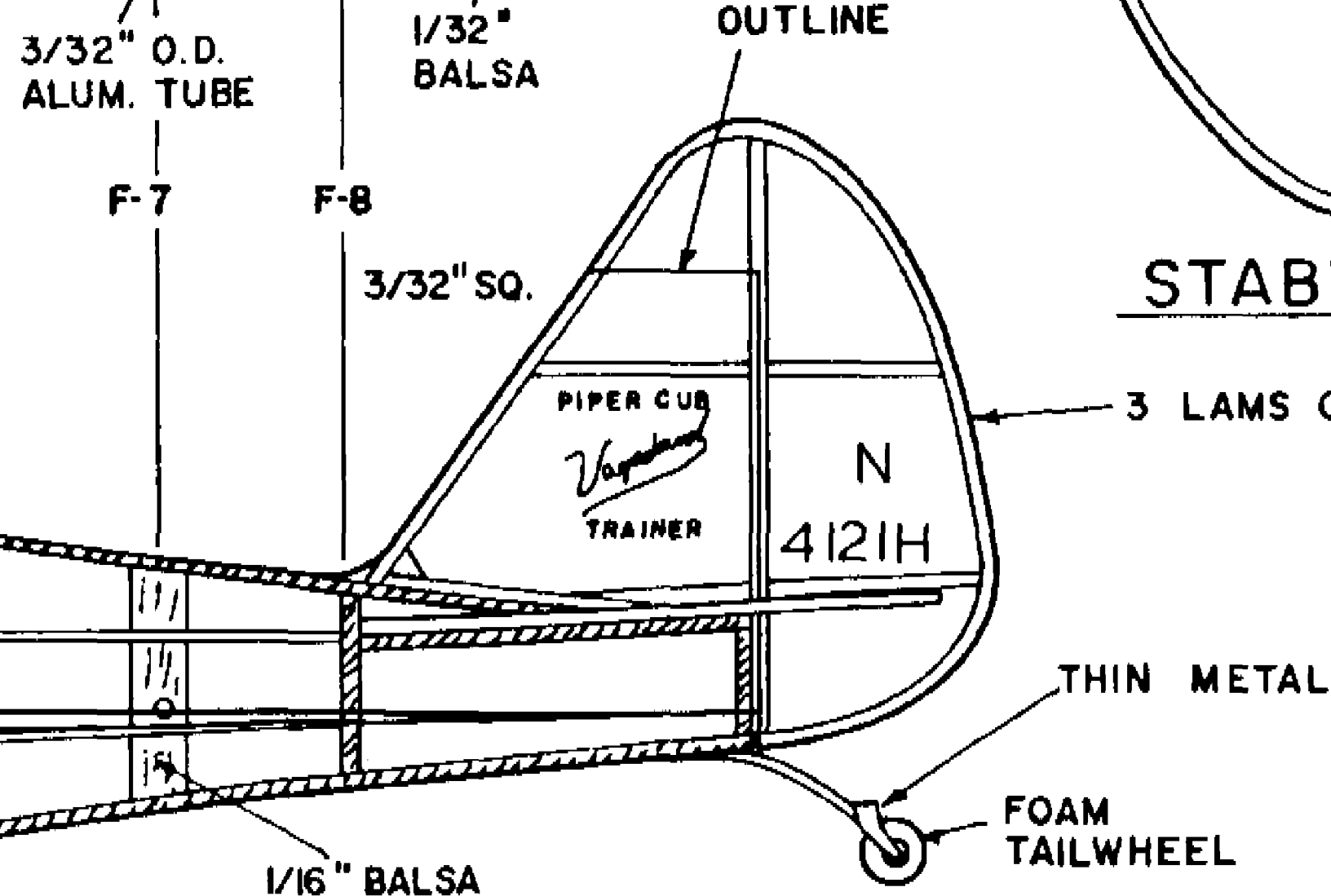

POWER WITH 4 STRANDS OF
1/8" TAN II RUBBER 30" LONG,
BRAID TO ELIMINATE SLACK

WING SPAN.....26"
WEIGHT.....1.2 OZ.
RUBBER POWERED SCALE

MODEL AV	
PIPER PA-1	
DESIGNED & DRAWN BY	
INKED PLAN BY JOE	
ALL RIGHTS RESERVED	SHEET 1 OF 1

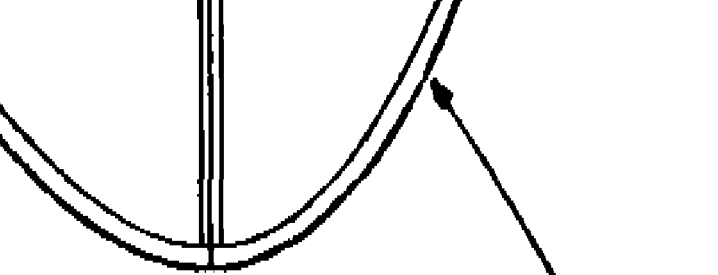

TABILIZER

LAMS OF 1/32"x3/32" BALSA

METAL STRUT

EL



AVIATION

PA-17 VAGABOND

N BY DAVE ROBELEN

Y JOE DEMARCO

T
I

#902