

Noorduyn NORSEMAN MkIV
 28" Span Free-flight Model
 Designed by Peter Wank for
 ScienText, Westport, CT
 © Peter Wank 1994

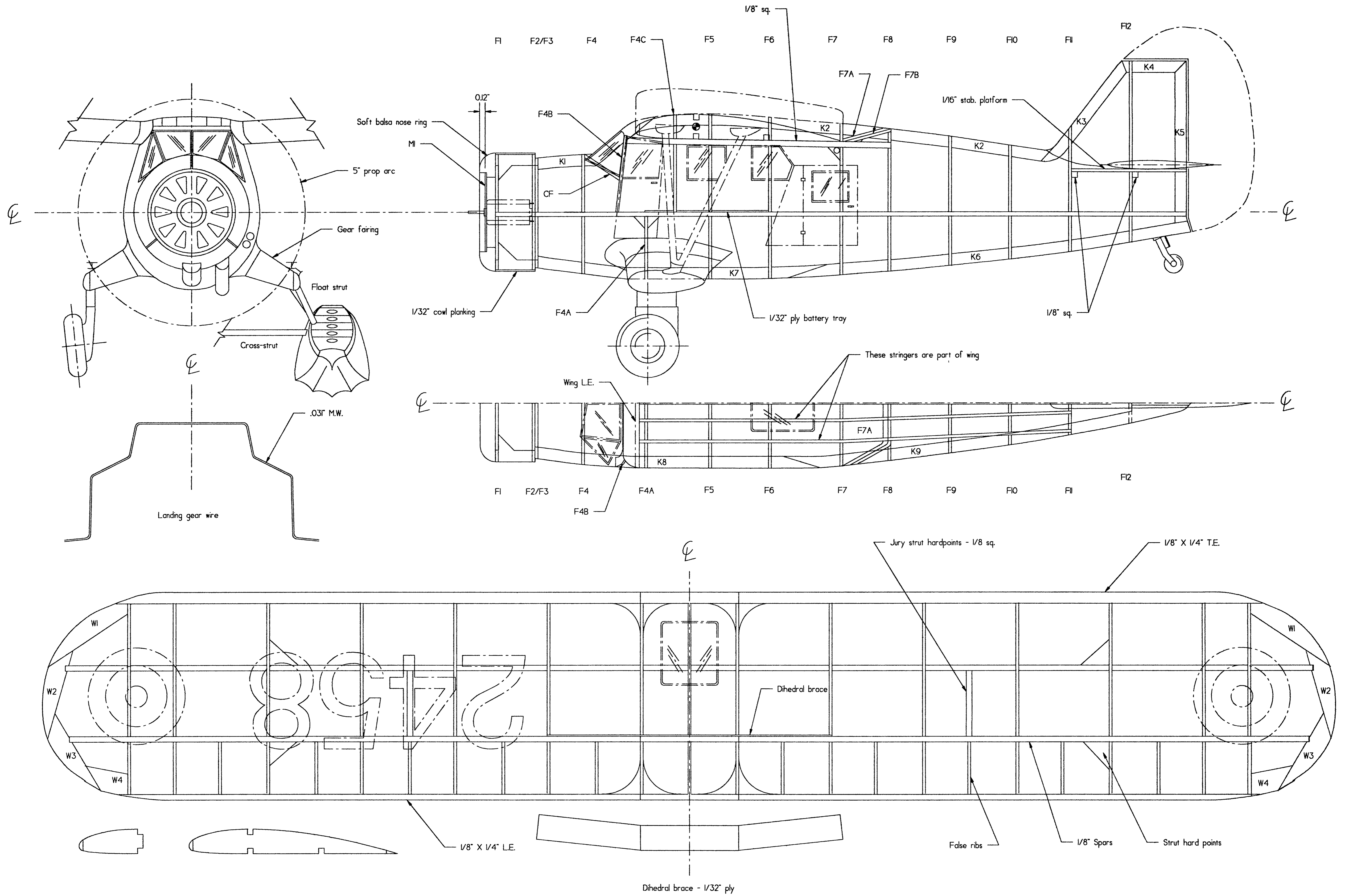

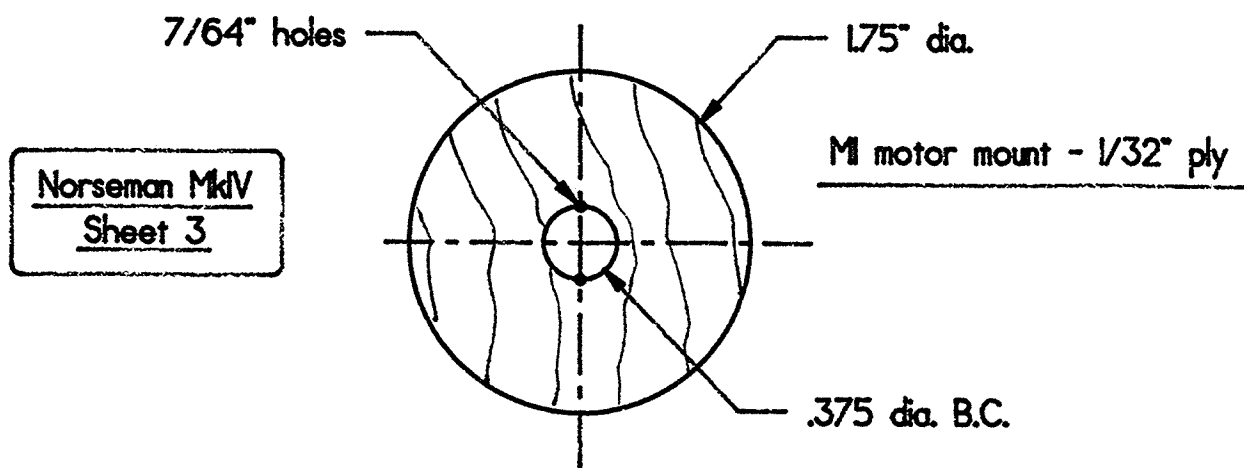

Norseman MkIV
Sheet 3

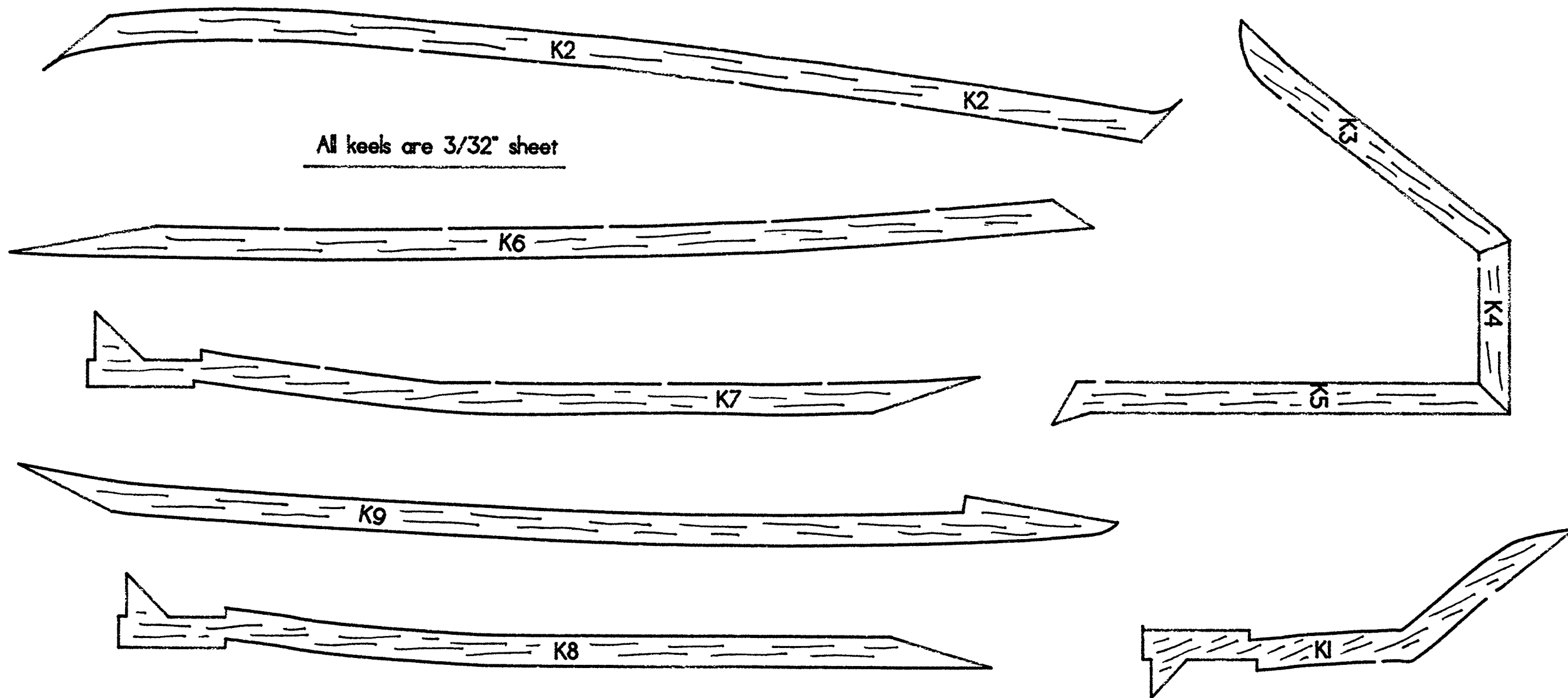
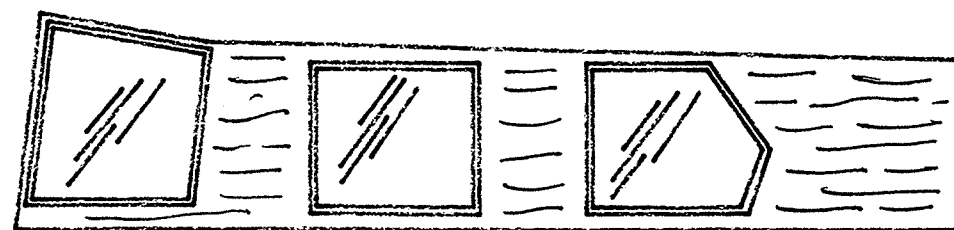

Window frames - 2 req'd.

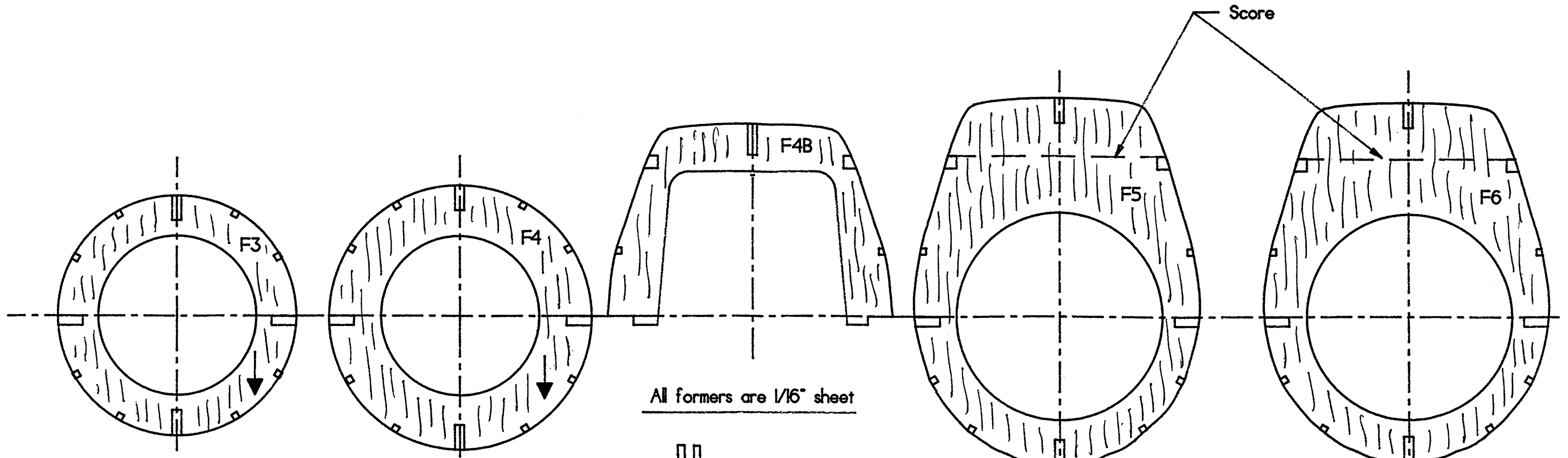

Norseman MkIV
Sheet 4

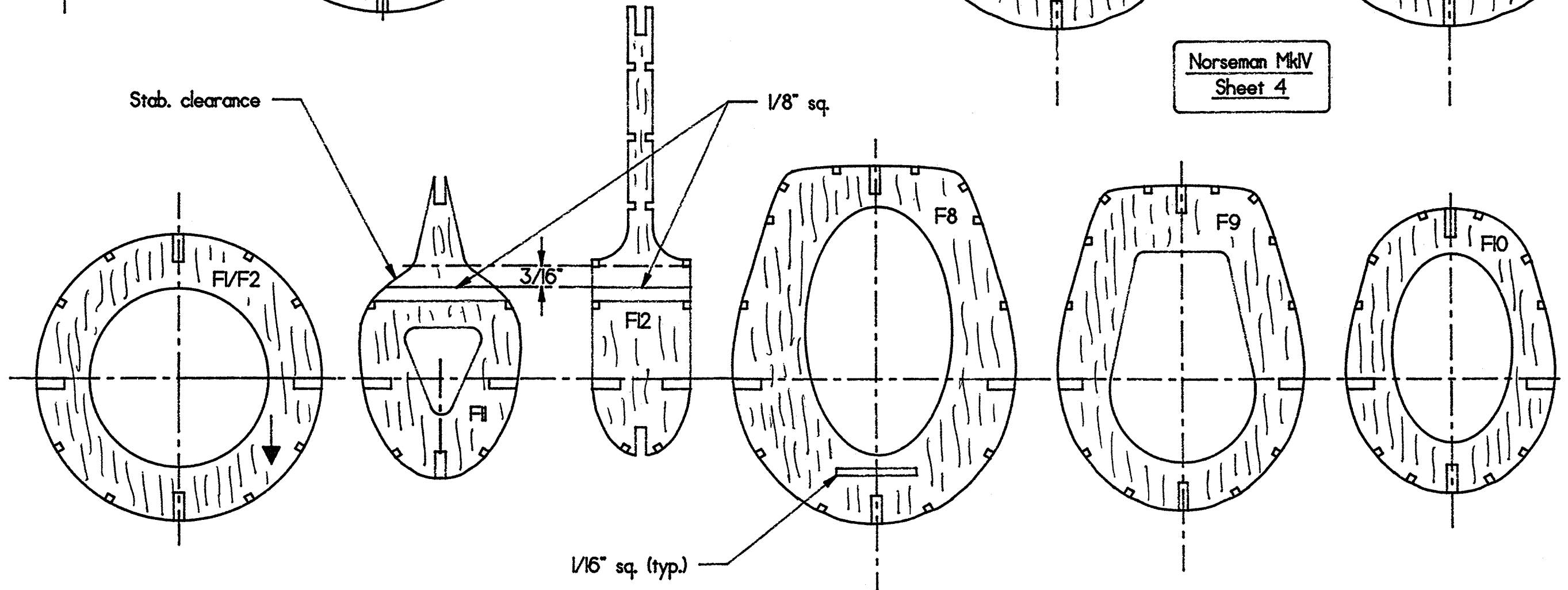

Full ribs - 15 req'd.



False Rib (10 req'd.)

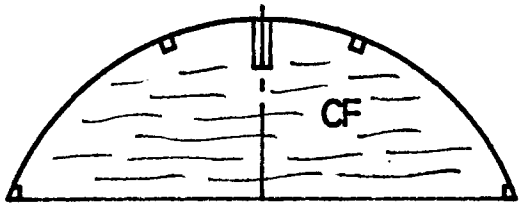

F6

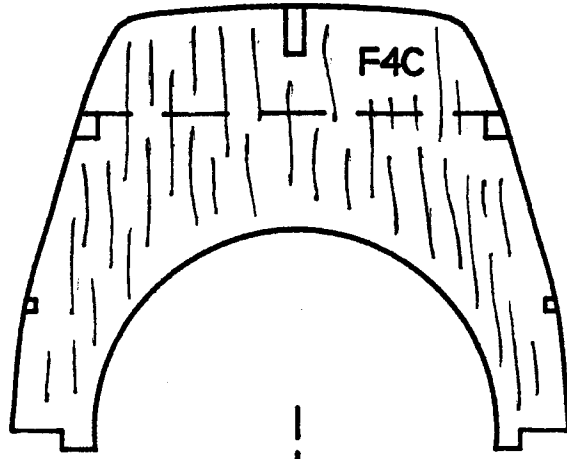

F4C

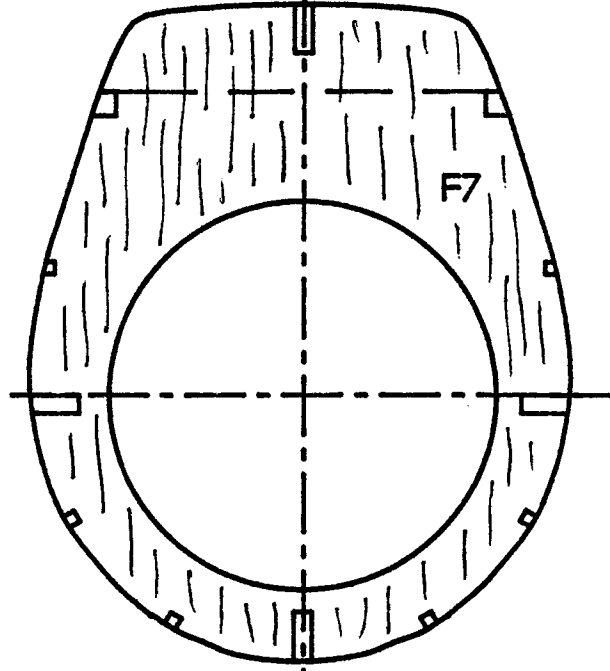

F7

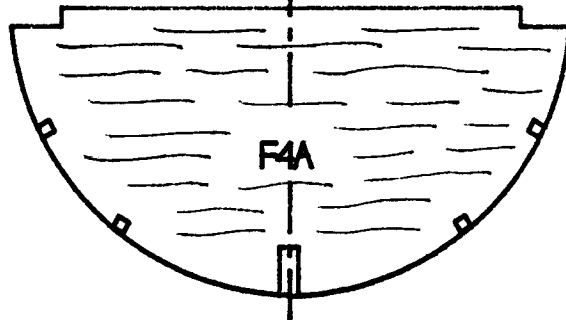

F4A

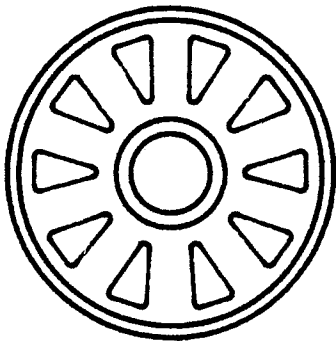

Engine cover

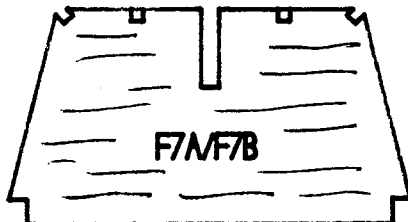

F7/F7B

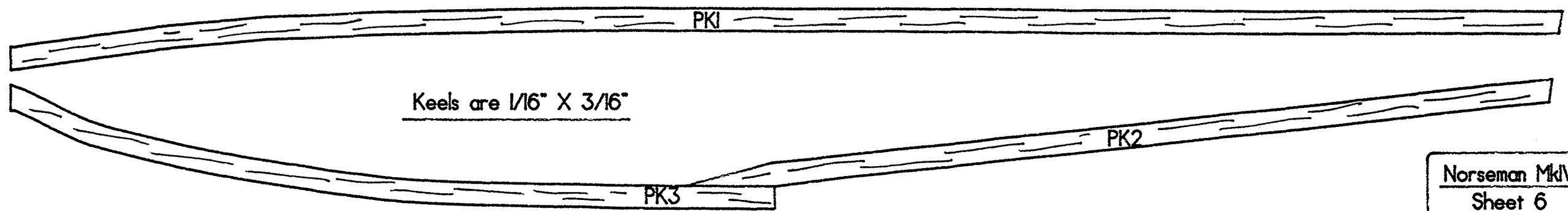
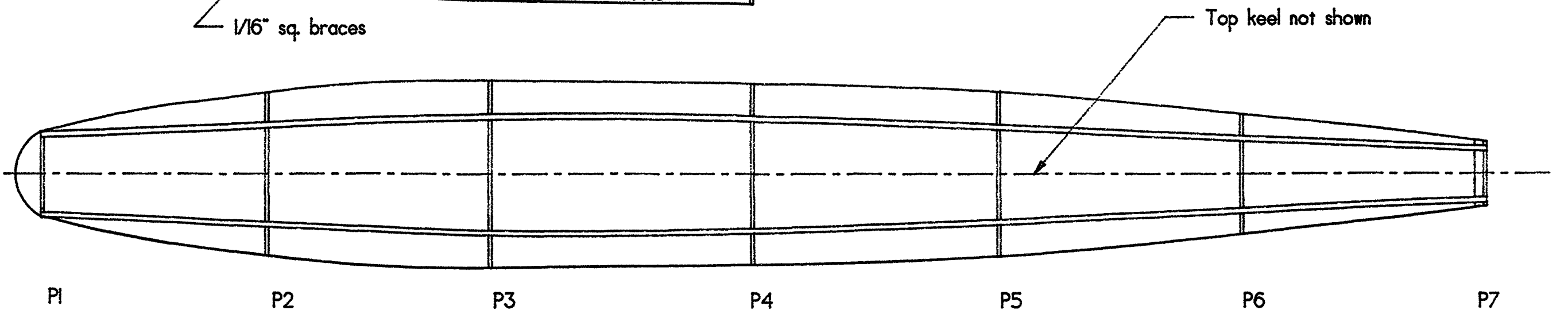
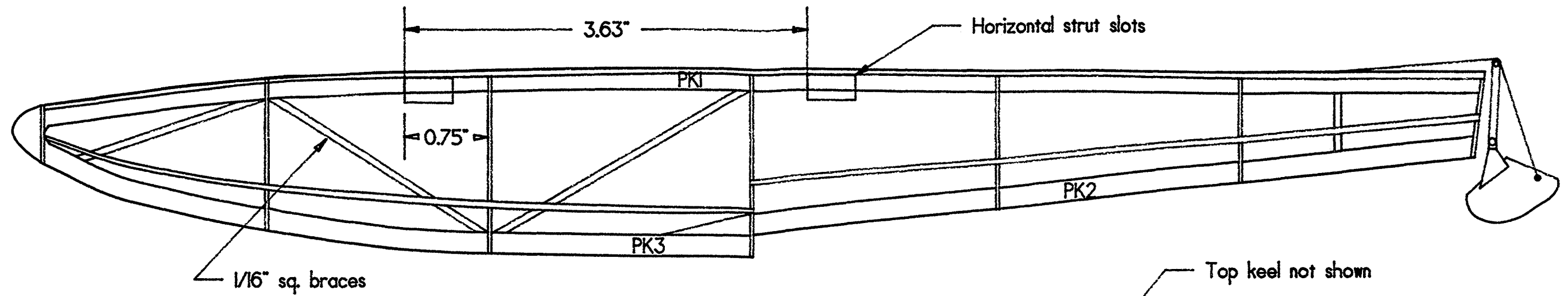

Norseman MkIV
Sheet 6

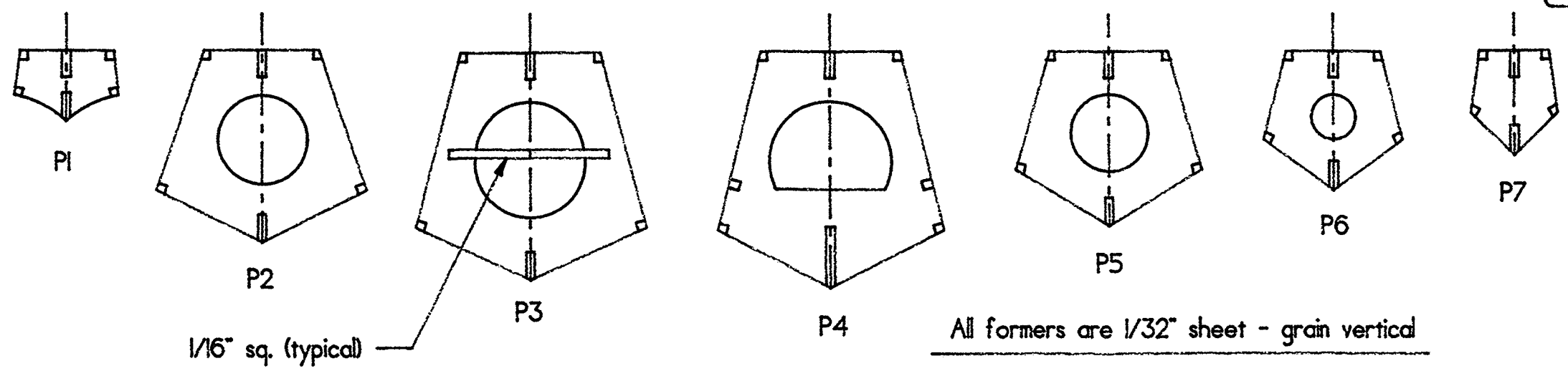

Norseman MkIV
Sheet 7

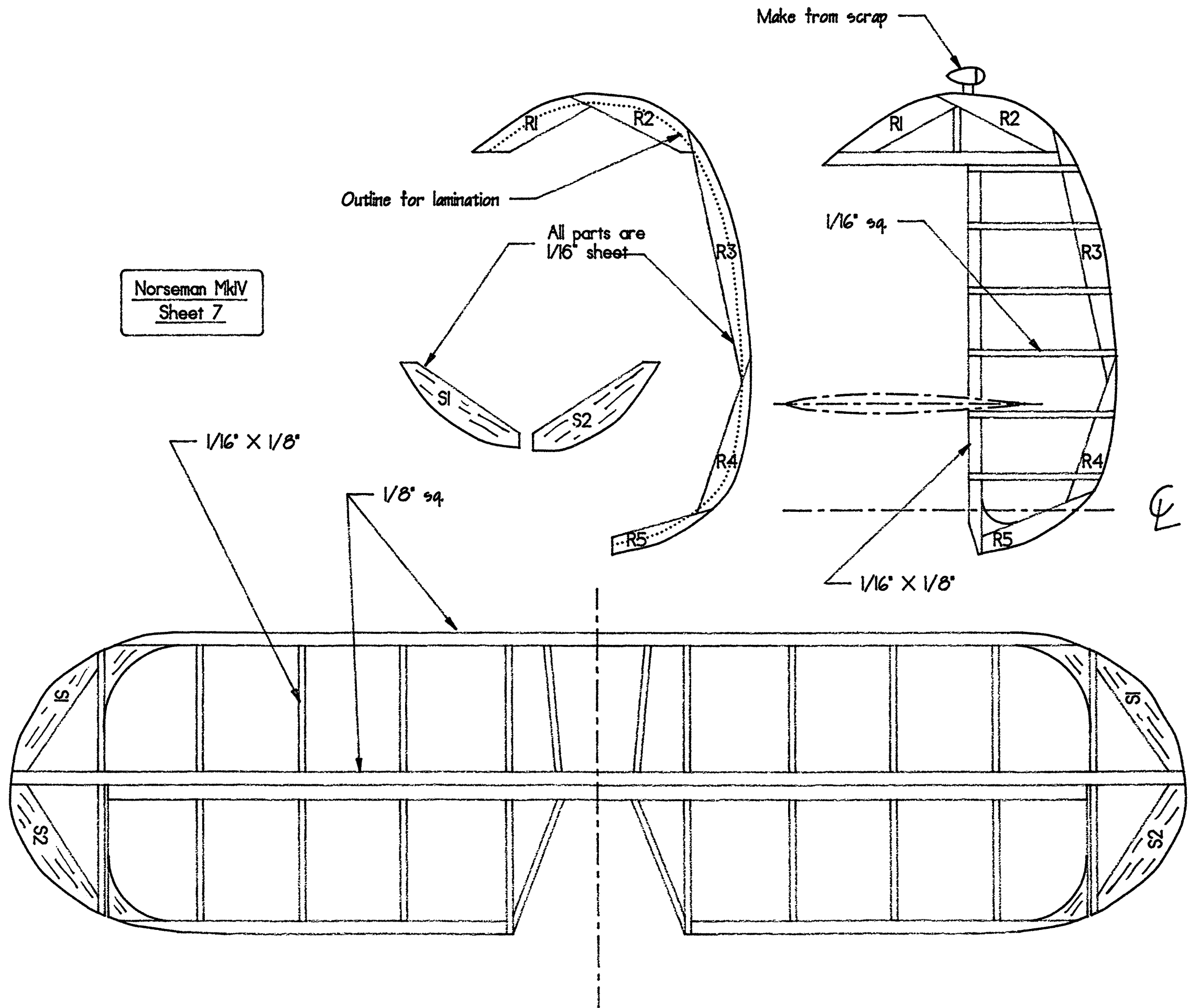

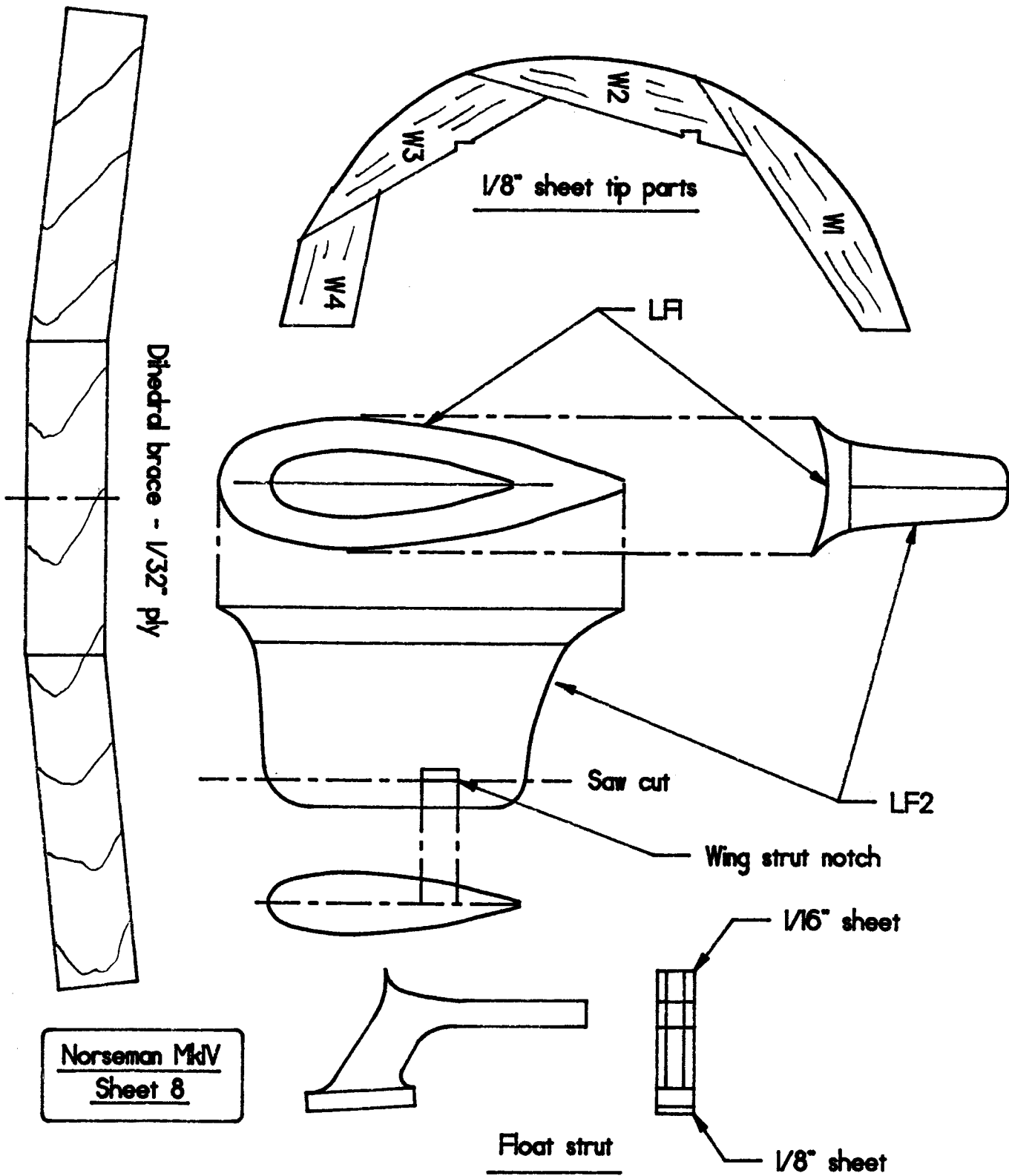

Norseman MkIV
Sheet 8



NORSEMAN LANDPLANE

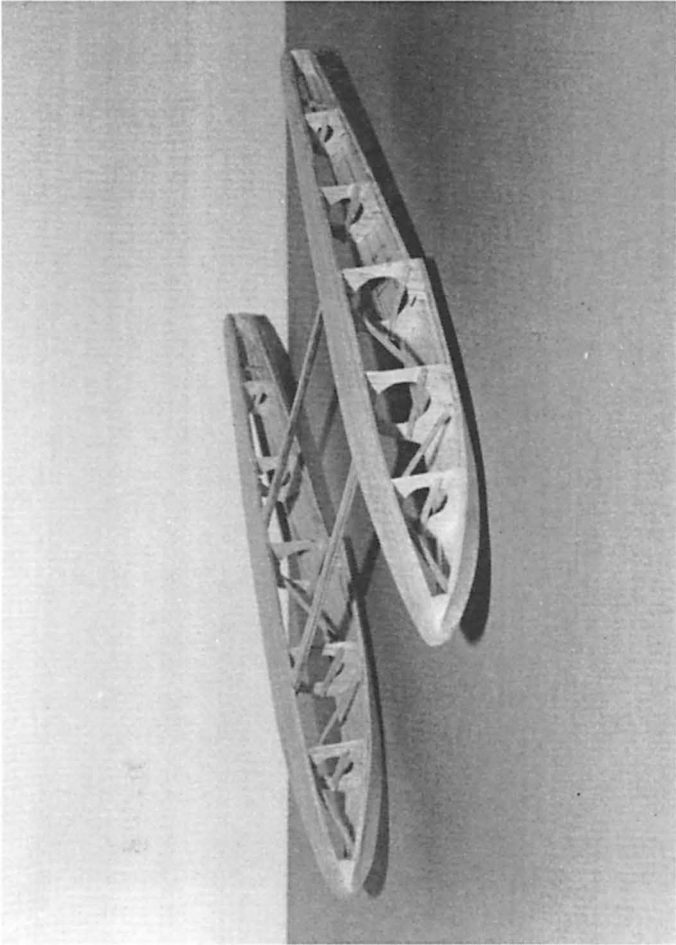

Noorduyn Norseman Mk IV

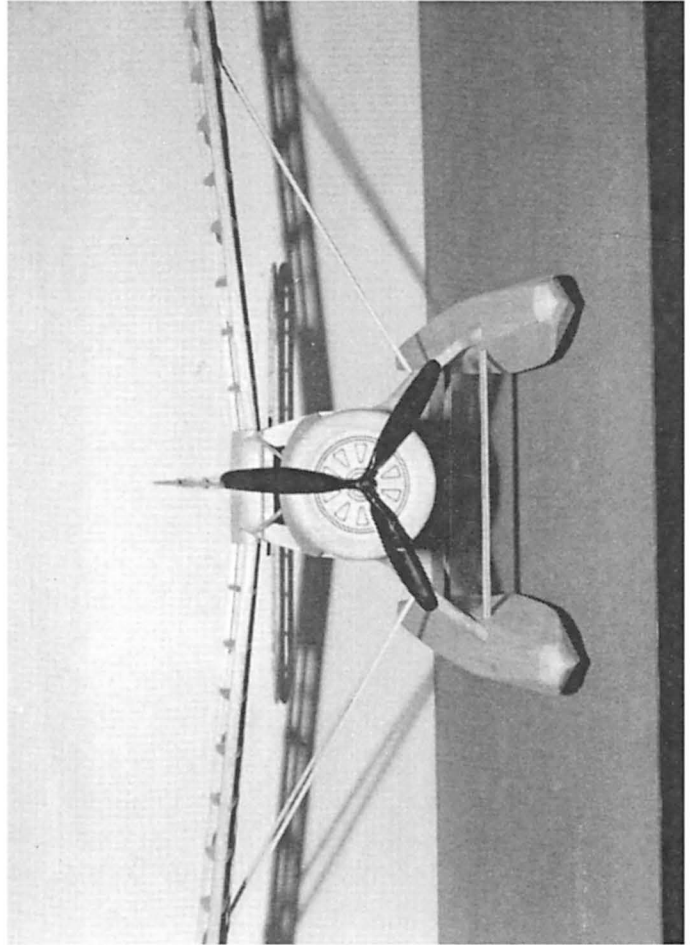
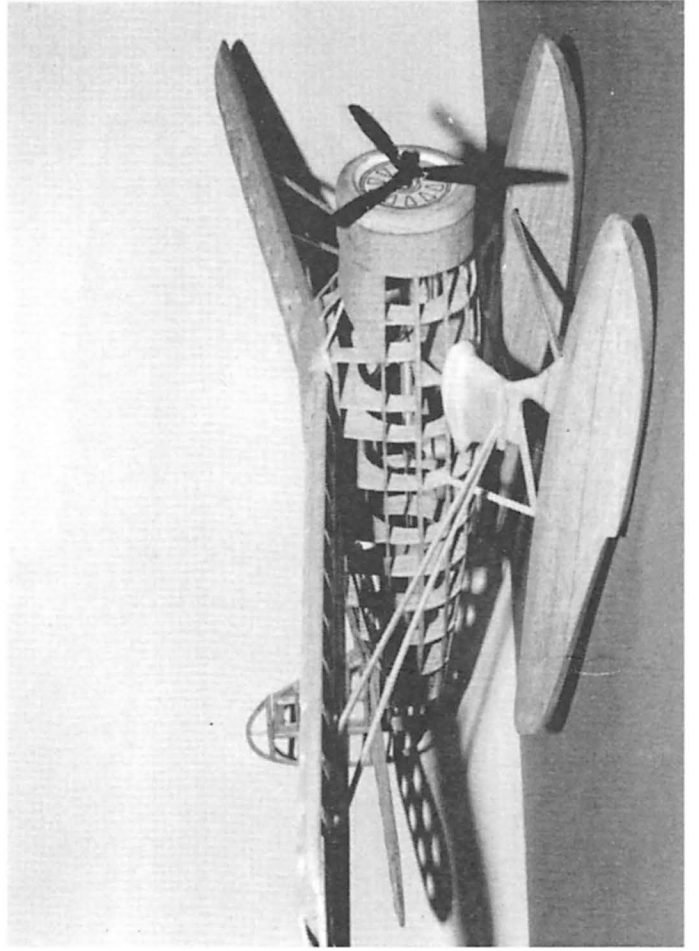

NOORDUYN MkIV NORSEMAN

Designed for ScienText

by Peter Wank - 1994

Designer's Notes:

I first became really "aware" of the Noorduyn *Norseman* series of aircraft after reading articles in *Skyways* magazine (July 1990. #15). Up to now, I'd never built, let alone designed, any floatplanes at all, and this one seemed to be a good place to start.

In doing the initial design work for the model, I was fortunate to have the assistance of Mr. Robert H. Noorduyn, who supplied much original factory data, including drawings, specifications, and photos, as well as criticism as the layout progressed. He also gave permission to use the photo appearing as the cover of this Manual. Any errors, omissions, or discrepancies are solely the fault of the above designer.

On some aircraft, nose shutters were installed during winter operations to control crankcase temperatures. A pattern for this shutter is provided - simply cut it out, and glue it to the motor mount in lieu of cylinders.

The *Norseman* series, from MkI to Mk VII, began with the first flight of float-equipped c/n 1 on November 14, 1935, and pretty much ended with the MkVII in the early 1950's. Of a total of 903 built, about 70 are still flying.

There were many variations in the design, in addition to the landplane versus floatplane versions. 93 MkIV's were sold to several customers, including to the USAAF as the YC-64 and the C-64B in the mid-1940's, as well as a number to the RCAF. For those of you with more interest in the historical aspects of the *Norseman*, I recommend the aforementioned issue of *Skyways* magazine.

As to the model, the wing chord has been increased about 16% to provide enough wing area to give a comfortable wing loading number. Also, the horizontal tail has been increased in area by about 20%. The only other major departure from scale has been

the use of MkV float struts in lieu of the ones used in the MkIV - they were simpler in appearance, and offered a bit more strength in a critical area. Bob Noorduyn comments that our version here could be more accurately referred to as the MkVI.

The wing is held in place with a single rubber band at the trailing edge, and a V-notch arrangement for the leading edge, which, it is hoped, will reduce any damage in a tip-down landing since the wing is free to move, and can disengage from the fuselage.

The pre-production prototype of the model was built as the floatplane version, but data is supplied should you wish to build the landplane. Since the construction is so simple, no vac-formed parts are included with this kit. The decals supplied are for the RCAF version, and the color scheme is international orange, ("schoolbus yellow").

Wings:

Since the wing will be needed for fitting fuselage parts, I suggest that you build the wing first. Cut the tip parts W1-W4 from soft, 1/8" balsa, and the ribs from 1/16" sheet. Cut the dihedral brace from 1/32" ply, using the pattern provided. All spars are 1/8" sq.

Build the wing in any manner you like, but it's probably faster to install the false ribs after the L.E. is in place. Cut away the R1 ribs, 1/32", behind the front spars, to accept the brace.

With the center section pinned down to the bench, add the outer panels for a dihedral of 1½" at each tip.

Plank the center section, top only, from L.E. to the front spars with 1/32" sheet.

Fuselage:

From 3/32" sheet, cut out keel parts K1-K9, as shown on the plans. Remember to cut two each of K8 and K9. Cut the formers from

1/16" sheet, observing the grain directions shown on the pattern sheets. Cut partway through the dashed lines on the tops of F4B, F4C, and F5 through F7. These score lines will make the later removal of these parts easier.

Add short pieces of 1/16" sq. across the formers at the top and bottom keel positions to reduce splitting on installation.

Note that there are no 1/16" notches on the tops of F4B through F7, since these portions of the upper fuselage will be removed and discarded later.

Pin down the keel parts over the plans, glue together, and mark the positions of each former, F1-F12 on the keel parts. The formers are not uniformly spaced, and their positions must be accurate. Mark also the cutout on K5 for the stabilizer clearance slot, and the positions of F7A and F7B on K2.

Remove the top and bottom keels from the plan, and add all the formers, except for F7A, starting at F1, and working to the rear. Add the side keels, K8 and K9, paying careful attention to straightness of the assembly.

Install all 1/16" stringers, including the ones from F8 to F11 on the top. Plank the area between F1 and F2 with medium 1/32" sheet to form the cowling. The area from F3 to CF was planked on the prototype, but this was a whim on my part, done for appearance, and is not necessary.

Add the 1/8" sq. battery tray supports, and the 1/32" ply battery tray. Before installing the tray, apply double-sided servo tape to the top to hold the NiCd pack. On the prototype, the battery pack ended up being located at exactly the correct C.G., so the shelf doesn't need to be very long.

To make the "nose ring", cut a piece of 1/32" ply to the same diameter as F1, and drill a 1/4" hole in the center. Glue pieces of 1/4" X 1/2" soft sheet balsa to the face of the ply, with the grain perpendicular to the diameter - it will take 5-6 pieces, depending on length. Using a 1/4"-20 bolt as a mandrel, chuck the assembly in your drill press (or lathe, if you have one), and turn down the ring to the shape

shown in the side view. In the front, cut in a 1.75" dia. recess, 1/8" deep (max.) to accept the M1 motor mount. Now, cut away the 1/32" ply within the ring, and install M1.

Give the engine cover pattern a spray of Krylon (not dope!), and glue it onto M1. Install the ST-2 motor, using the hardware supplied. Solder the motor leads to the motor terminals per the Wiring Diagram, and test for proper rotation direction. From now on, access to the motor will be very difficult, so make sure everything's right.

Glue the completed nose ring assembly, with motor, to F1, and lead the wires back into the fuselage.

With a razor saw, cut away the tops of formers F4B through F7, on the previously scored lines, back to the diagonal cut in K2 between F7 and F8. Discard the cut-off parts, and block-sand the tops of the formers for flatness. Note that F7A installs on the wing - not on the fuselage.

Tape or pin the wing into position, with the T.E. directly above F7. Put waxed paper between F7A and F7B, and glue F7A to the wing. Add balsa pieces to the top of the wing center section to compensate for the tops of the formers just removed, and add the 1/16" stringers, lining them up with the ones already on the fuselage.

From medium balsa, carve a block to fit on top of F4B, and to accept the wing L.E., running the grain across the fuselage. The inside curve of the block must be a good fit to the L.E. Sand the entire upper fuselage/wing area to blend in the contours. If everything looks good, give the inside curve of the carved block a coat of CyA+ to harden it.

With the wing fitted into position, and the hold-down dowel located in front of F7, the rubber band across the wing should wedge the wing into the block tightly enough for flight loads, and yet loosely enough to allow the wing to pivot in a hard landing. Note also that the wing struts are glued to the strut hard points, but are not glued to the notch in the landing gear fairings.

Make a switch panel from 1/32" ply, and install it in the fuselage in whatever position you find convenient for launching. On the prototype, it was placed behind F6, on the right side, just above the side keel.

If you elect to use the external charging wires, as shown on the Wiring Diagram, drill two 1/16" holes through the panel for the wires. Drill the holes before installing the panel! (I much prefer this method over a charging jack, which is expensive, and not easy to solder and install).

Cut away the stabilizer notch on K5 and F12, and install the 1/16" stabilizer shelf to the 1/8" sq. pieces.

From 1/32" sheet, and using the patterns on Sheet 3, make two window frames. Cut out the windows, cover or paint one side, and glue celluloid on the inside. The patterns are oversize - trim from the bottom. The windows should be flush with the rest of the structure, so sand away 1/32" from the sides of F4B to F6 in this area.

Floats:

From 1/16" sheet, cut out the keel parts, remembering that you are going to make two floats - one port (left), and one starboard (right). From 1/32" sheet, cut out float formers P1-P7, keeping the grain vertical. Pin down the keel parts to the plan, and glue together. Before removing the keel from the plan, mark the positions of formers P1-P7 on the top and bottom keel parts. Don't forget the 1/16" sq. braces between the keels.

Starting at the front, install all formers, and add the 1/16" sq. stringers, keeping the keels straight as you go along. When the glue has cured, block-sand all sides to remove any bumps. With medium 1/32" sheet, plank the top and bottom of each float - leave the sides open for now.

Draw two parallel lines, 6¼" apart on a piece of paper - these represent the float centerlines. On the inboard side of each float, notch the upper 1/16" stringer, and the upper keel, to accept the 1/4" X 1/8" cross-struts at the positions shown on the side view in the

plans. Pin each float into position, upside down, over the parallel lines. The cross-strut positions shown are such that, with the rear strut aligned with the F6 fuselage former, the floats are correctly located along the longitudinal axis of the airframe.

The cross-struts are made from hard balsa, with a bamboo skewer, or 1/16" dia. dowel, acting as the leading edge of each strut, to add stiffness. Sand the struts to an airfoil shape.

With the floats pinned down, securely glue the cross-struts to the floats and allow to dry completely.

You can now plank the sides and add the noseblock, sanding everything smooth. If you intend off-water operations, check all the seams for open areas.

Add the water rudders and cleats after covering.

Landing gear fairings:

The landing gear fairings are identical for both the floatplane, and the landplane versions. Cut the LF1 and LF2 parts from soft ¼" sheet, keeping the grain for all parts in the horizontal direction. Cut away the interior of LF1, and, using a 3" O.D. coffee mug as a sanding tool, sand out one side to conform to F5. (Don't forget - one port, one starboard!).

Glue-stick together the LF2 parts in pairs, and shape the outsides to the contours shown. Soak the pieces apart, and hollow out the interiors - a Dremel drum sander makes this very quick. Glue them back together, and with a razor saw, carefully cut away the portion of LF2 as shown on the plan. Cut in the notch for the wing struts, and glue the sawn-off piece back on.

Assemble the completed fairings to the fuselage, with the inside edges of the bottoms of the fairings 4¼" apart, and the front of the fairings 2 7/8" from the front of the nose. These should be only tack-glued in place, since you'll be removing them later for covering the fuselage.

Make the float struts from a lamination of two pieces of 1/16" sheet, and one of 1/8"

sheet, cross-grained. Pin the bottoms of the struts to the board, with the inside edges 5¼" apart, and test fit to the gear fairings, making any angle changes as needed. Glue the struts to the fairings. If everything fits, lift the fuselage and struts off the board, and glue the struts to the floats, checking alignment carefully.

If you're doing the landplane version, ignore the float struts, and use the .031" wire shape as shown on the plans for the wheels. The gear wire attaches to F4A. In forming the landing gear wire, leave the axles extra-long for final fitting.

As of this writing, we haven't been able to identify a maker for the vac-formed wheels. If you're building the floatplane, this doesn't matter, but if you intend the landplane, please send us a self-addressed postcard, and we'll ship the wheels to you (free) whenever we get them.

(One note: In the floatplane version, the floats are connected to each other, and/or the fuselage in 12 places! This means that it's nearly impossible to design a structure to absorb landing shocks, so you can either make the structure as strong as possible, or glue it very lightly together so it'll tear away in a hard landing, doing as little damage as possible to the rest of the structure. The same general problem applies to the wheeled version, but to a lesser degree).

Tail Group:

The vertical fin is built as part of the fuselage. Don't install the 1/16" stringers on it until the rudder is completed and available for fitting. Build the stabilizer and elevators as separate components for joining after covering.

The rudder can be built using the parts shown on the plans, but the prototype used three laminations of 1/32" X 1/16" balsa, soaked and bent around a waxed cardboard form, using Elmer's White Glue. If you elect to laminate, the dotted line on the rudder patterns gives the contour for three, 1/32" laminations. Obviously, the stabilizer and wingtips

could be made in the same manner.

Masking-tape the rudder to the fin, with a 1/32" shim between them, and install the 1/16" stringers. Cut the rudder and fin components apart, and sand in the airfoil. Hinges can be made from soft iron wire, bag ties, or aluminum Coke can material.

Motor installation:

As mentioned earlier, make sure that the motor turns in the right direction before gluing the nose assembly into place. The black nylon adapter must be drilled out to 0.059" (#53 drill bit) to accept the motor shaft. If you don't have a bit of this size, they're available from us at \$1.10. Note that the conical part of the adapter faces the rear. Also, the shaft hole in the prop must be drilled out to 1/8" dia., which will give a good press-fit to the adapter.

The battery pack in the prototype was a 4X90 mAh unit, but I suspect that a 4X50 mAh pack would be adequate - depends on how large a flying field you have. A drop of CyA on the shaft is a good idea, but don't let it seep into the motor bearing.

The spinner comes with the prop, as we buy it, but it is incorrect for the *Norseman* - they weren't used on the real aircraft.

If you give the prop a good burnishing with #0000 steel wool, it'll look even better. Testor's Gloss Silver enamel is a good paint for the prop.

(Note: all of the motor components are available separately - write for our free Accessory Listing, and include a #10 SASE).

Covering and Finishing:

Prior to covering, the prototype weighed 3.7 oz. (106 gm.), with motor installed. The all-up, RTF weight of the completed *Norseman* was 5.5 oz. (156 gm.). Areas of the flying surfaces are: wing - 125.44 sq.in., horizontal tail - 30.1 sq.in., vertical tail - 11.43 sq.in.

For any painting work, I suggest acrylics - they're easy to handle, and have good coverage. If you use JCI yellow tissue for the RCAF

version, "Liquitex" #2002-416, Yellow Ochre is a reasonably good color match.

If you're doing the USAAF model, the tops of all surfaces are olive drab, and the bottoms are medium gray. The floats for all versions are aluminum, with black nose bumpers.

A plastic soda straw, painted flat black, makes a good exhaust pipe. The venturis were turned in the drill press from 3/16" dowel, and the black discs on the floats were punched from black Monokote trim with a one-hole paper punch.

A new product, "Litespan", sold by Charlie's (2828 Cochran St., Suite 281, Simi Valley, CA 93065-2793), is a very lightweight, fabric material that has enormous potential for small models like the *Norseman*. It requires painting the areas to be covered with "Balsaloc", the use of a sealing iron, and is fairly expensive (\$3.35 for a 20" X 36" sheet), but the appearance is marvelous, and no clear doping or Krylon is needed! It's also waterproof, very puncture-resistant, and comes in a slew of colors...

The fuselage is best covered in long strips, which is a tedious, but relatively simple procedure. Use whatever techniques you like for the rest of the airframe, but keep painting to a minimum. Covering the fuselage with the gear fairings attached is "difficult", so try to remove them before starting. The vertical fin should be covered with white tissue, and the red and blue color bars added over the white (for the RCAF version).

Make up the main, and jury wing struts, from spruce or basswood, and cement them to the wing only - they are for appearance only and are not structurally important. All float struts are spruce.

In the prototype, the NiCd pack mounted exactly at F4C - right at the C.G. Use double-sided servo tape to secure it, with a spruce cross-member directly above it, glued to F4C for further security.

Be careful about over-detailing - as I added details to the prototype, the elegance of the basic airframe seemed to become

overwhelmed by the details.

"Letraline" black striping tape, in various widths, is useful for panel lines, etc.

The decals are the normal, water-slide variety. If you happen to get into trouble, extra decal sheets are available for \$2.98, plus \$.52 S&H.

Flight Test:

The prototype required about 2°-3° of right rudder and up elevator, which gave straight and level flight. For initial flights, the 90 mAh pack was field-charged at 1 amp for 3 minutes. Start here, and work up to longer charges when the MkIV is trimmed out.

GOOD LUCK!

Late Changes and Clarifications:

1. The wheel is not centered about the gear strut. If you attach the landing gear wire behind F4A, it will be properly located. The drawing is correct as shown.
2. Numerals go on top of the right wing, and bottom of the left.

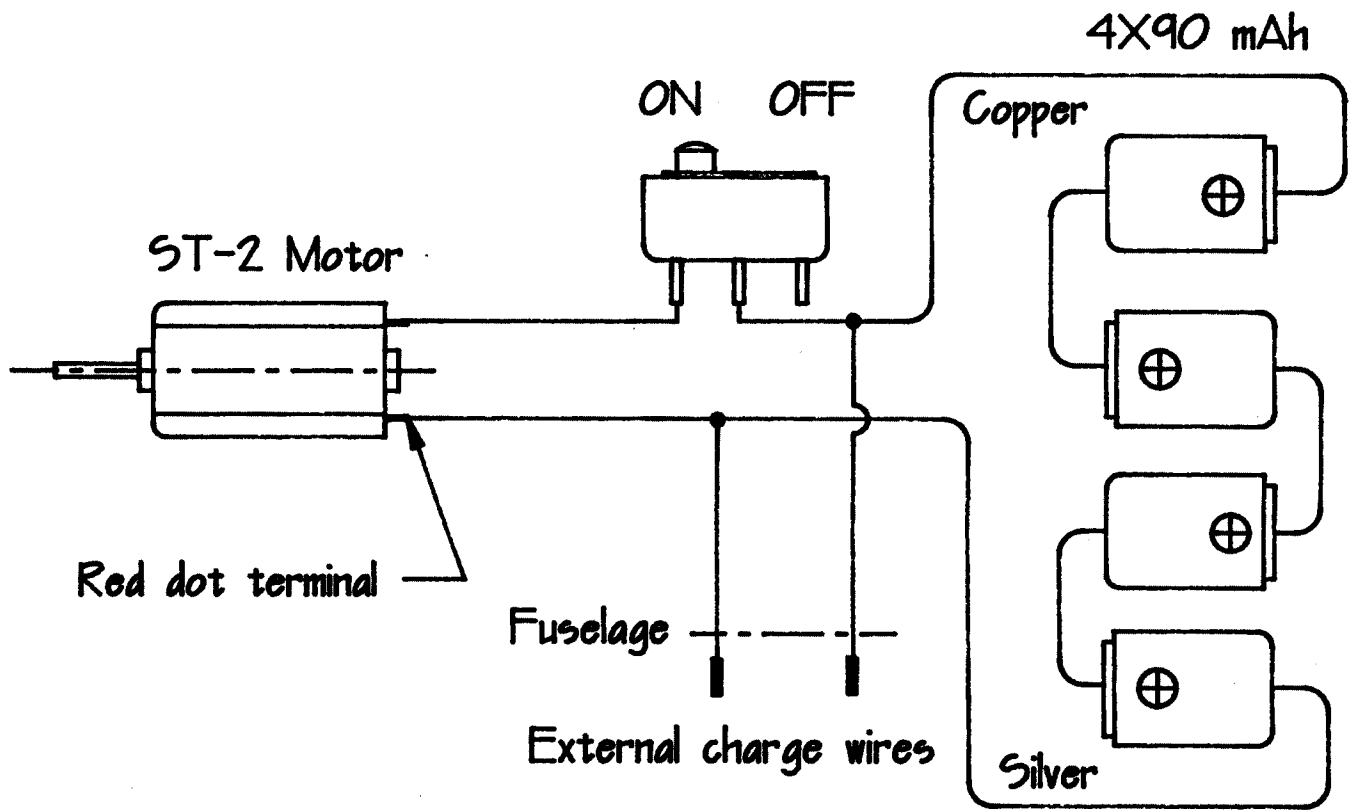

Norseman Wiring Diagram