

GENERAL INSTRUCTIONS  
STUDY PLANS AND PERSPECTIVE SKETCHES BEFORE STARTING ANY OF THE ACTUAL MODEL WORK. PIN PLAN TO A SOFT BOARD AND USE WAXED PAPER OVER PLAN TO PREVENT THE WOOD FROM STICKING TO THE PLAN.

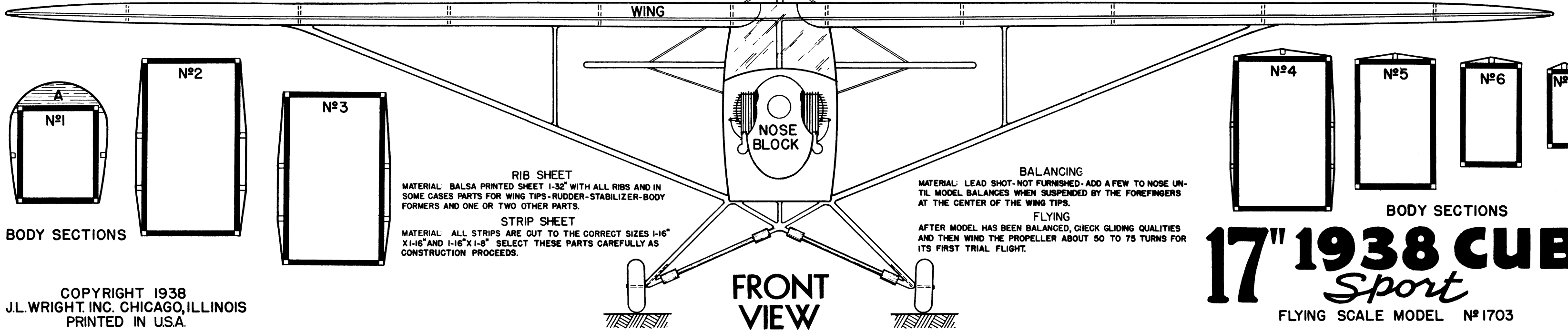

COPYRIGHT 1938  
J.L. WRIGHT, INC. CHICAGO, ILLINOIS  
PRINTED IN U.S.A.

17" 1938 CUB  
Sport  
FLYING SCALE MODEL N°1703

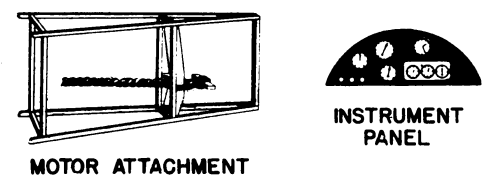
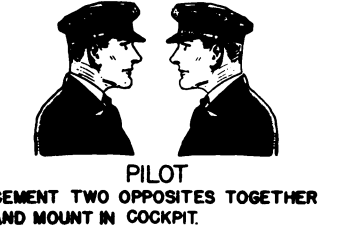
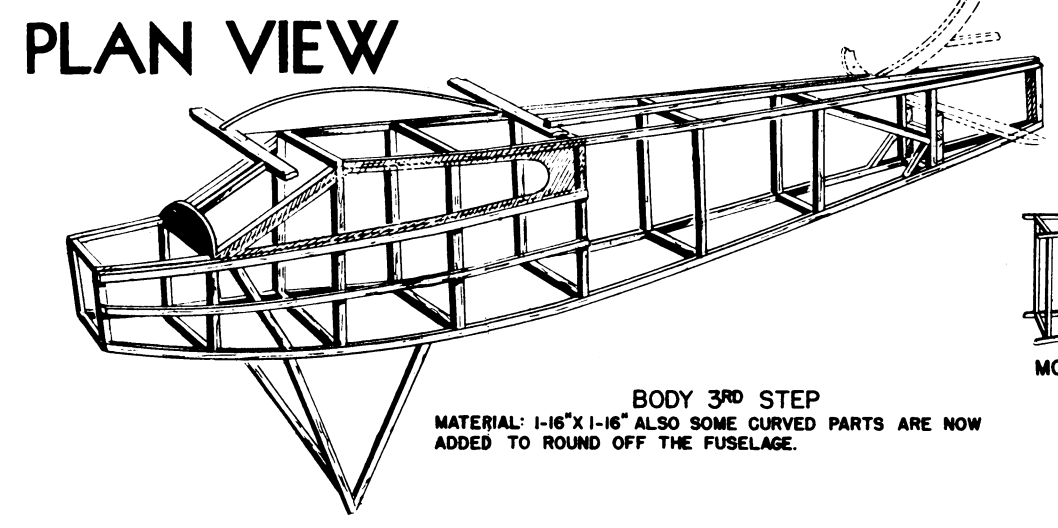
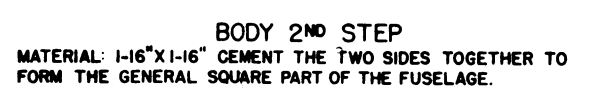
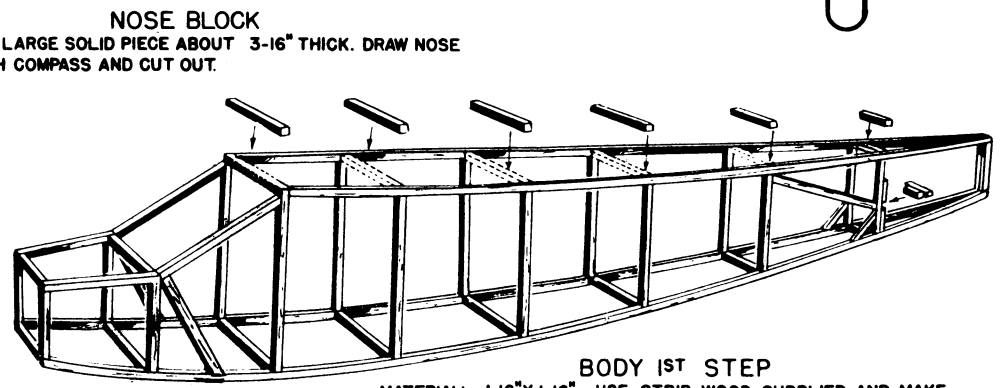
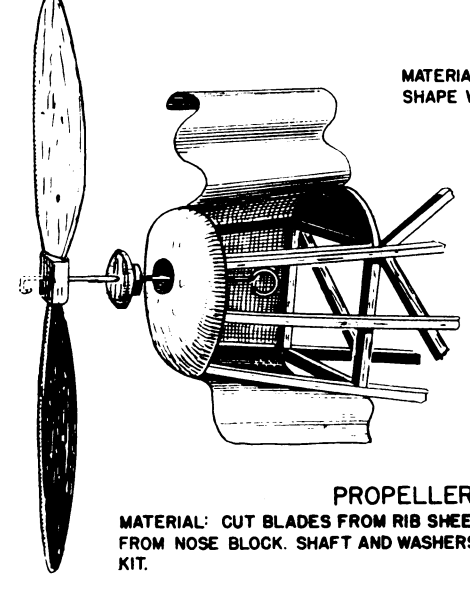
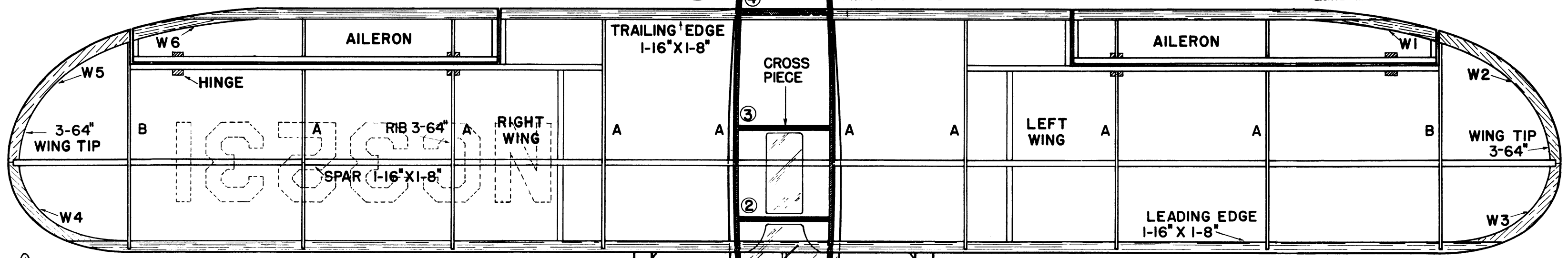
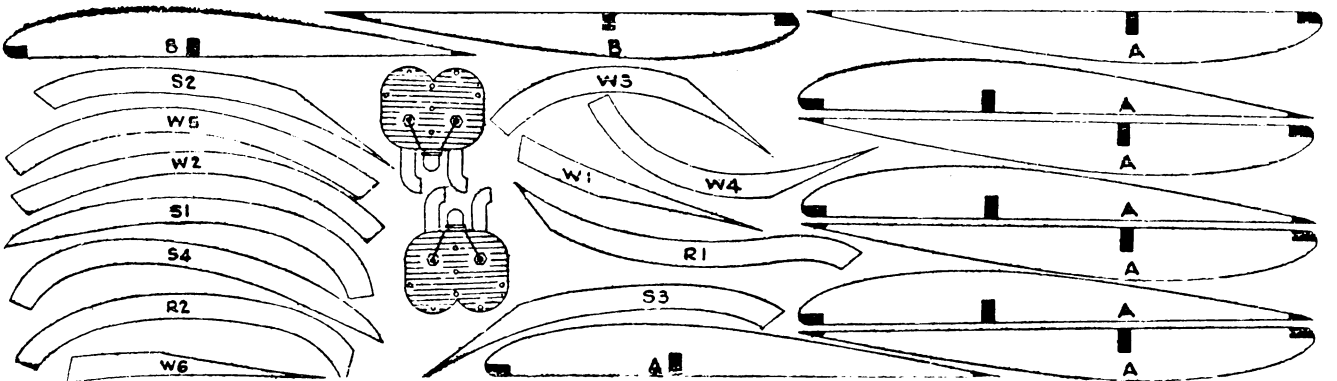
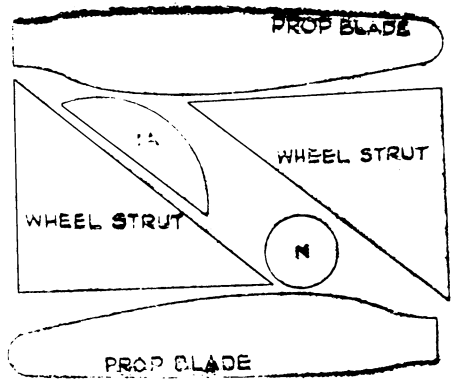

38 CUB SPORT №1703



17 inch  *flying*  
MODEL

Complete with  
**3 VIEW FULL-SIZE**  
plans

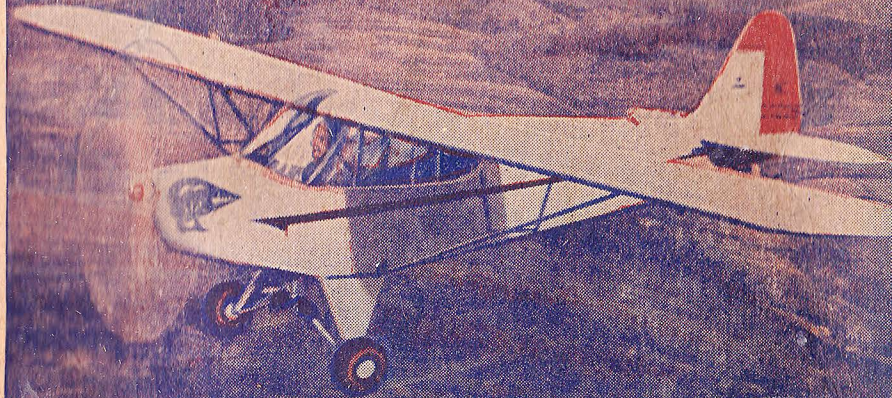

1938 CUB SPORT