

MADE OF HEAVY PAPER AND Balsa. MATERIAL NOT FURNISHED.

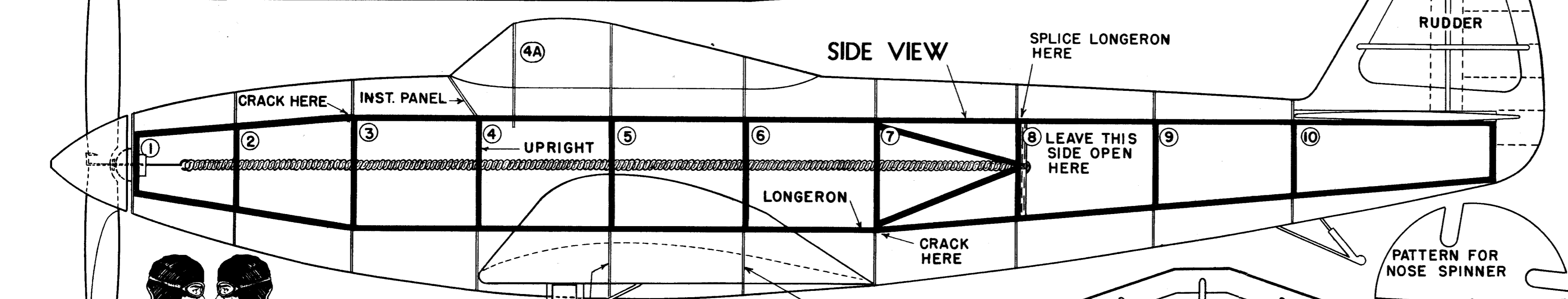

GENERAL INSTRUCTIONS ON ASSEMBLY OF OTT-O-FORMERS IN MODEL PLANE BUILDING

- STEP NO. 1 BODY SIDES 1/16" SQ. MATERIAL. MAKE TWO (2) SIDES, AND ASSEMBLE
- STEP NO. 2 CUT OUT PARTIALLY FINISHED FORMERS WITH A PAIR OF SHARP SCISSORS OR RAZOR.
- STEP NO. 3 PLACE COMPLETED FORMERS OVER FOUNDATION FRAME AND CUT NOTCHES FOR STRINGERS
- STEP NO. 4 CEMENT STRINGERS, 1/16" SQ. MATERIAL, INTO PREPARED NOTCHES ON FORMERS. IN MOST CASES CUT NOTCHES AS YOU PROCEED. FINISH ONLY ABOUT 4 TO 6 CENTRALLY LOCATED NOTCHES AT FIRST, ADD AS YOU PUT MORE STRINGERS IN PLACE.
- STEP NO. 5 COVER BODY IN SECTIONS AND USE AS LARGE A PIECE OF TISSUE AS POSSIBLE WITHOUT UNDUE WRINKLING.
- STEP NO. 6 CUT OUT PREPARED FORM OF ELEVATOR
- STEP NO. 7 CEMENT SPAR AND RIBS IN PLACE
- STEP NO. 8 COVER ELEVATOR WITH TISSUE AND IF DESIRED, CEMENT A HEAVY LINE FOR CONTROL OUTLINE.
- STEP NO. 9 CUT OUT PREPARED FORM OF RUDDER
- STEP NO. 10 CEMENT SPAR AND RIBS IN PLACE.
- STEP NO. 11 COVER WITH TISSUE AND CEMENT HEAVY LINES FOR CONTROL OUTLINE
- STEP NO. 12 CUT RIBS FROM RIB SHEET WITH RAZOR
- STEP NO. 13 COMPLETE WING TIPS AND PLACE IN POSITION ON DRAWING
- STEP NO. 14 PLACE LEADING AND TRAILING EDGES IN POSITION USE SMALL THIN PINS TO HOLD WOOD IN POSITION. WET WOOD IF BEND IS LARGE.
- STEP NO. 15 PUT LOWER SECTION OF RIBS, 1/16" SQUARE, IN PLACE, ADD SPAR OVER THESE 1/16" SECTIONS
- STEP NO. 16 CEMENT CURVED RIB SECTIONS, OVER SPAR, ON TO LEADING AND TRAILING EDGES.

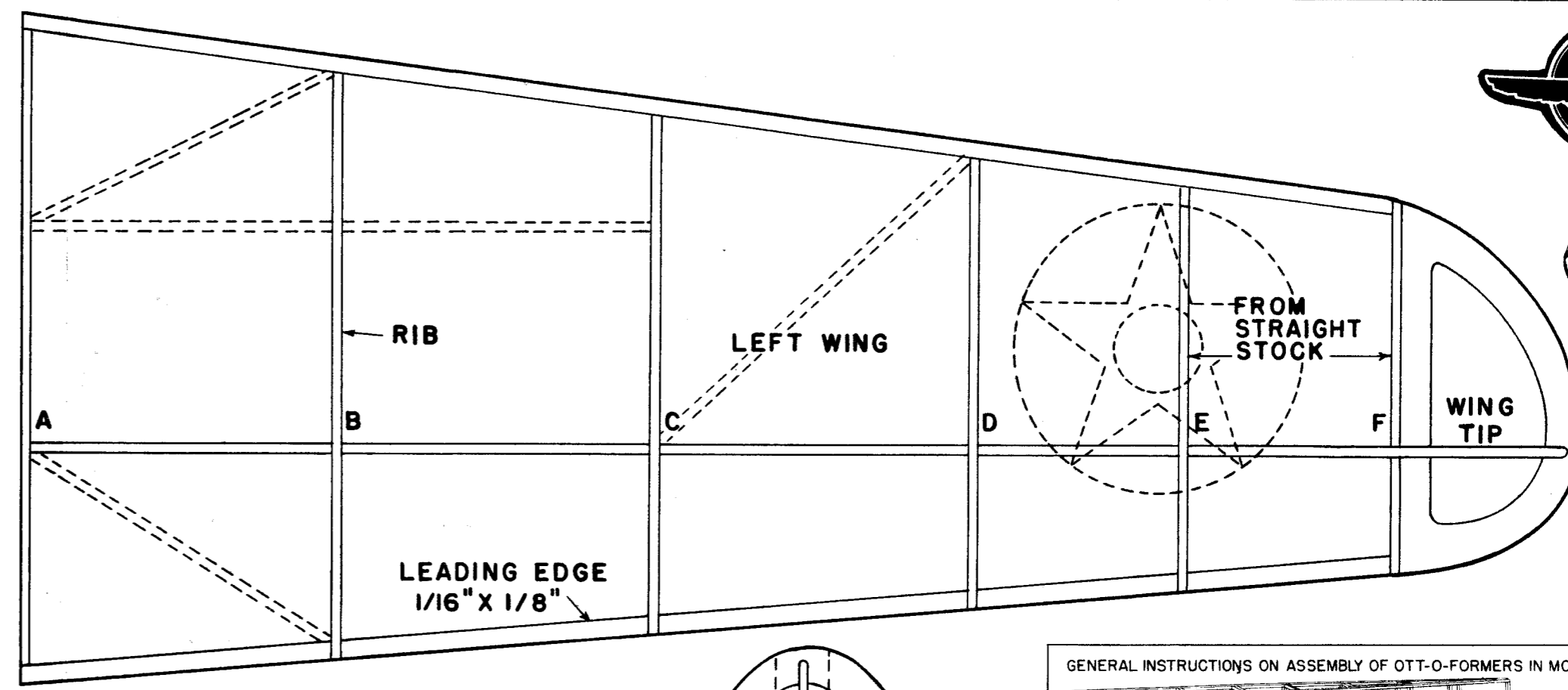
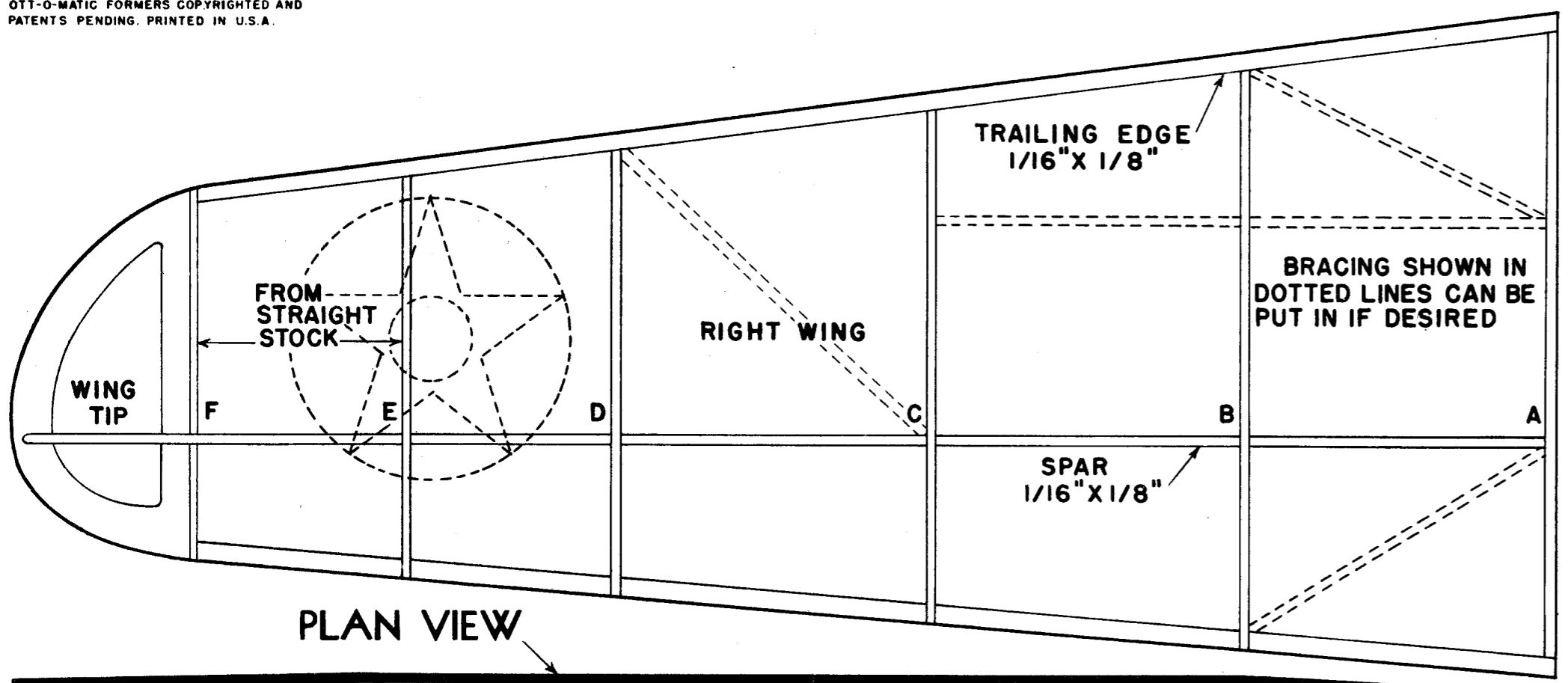

PILOT  
CEMENT TWO OPPOSITES TOGETHER AND MOUNT IN COCKPIT.

WHEN CEMENTING WINGS TO FUSELAGE, CUT OUT THE PART OF FORMER MARKED BY DOTTED LINES

**22" AIRABONITA**  
FLYING PLANE KIT No 2206  
DESIGNED BY JOE OTT

INSTRUMENT PANEL

