

MATERIALS REQUIRED			
1	LONGERONS	1/16" x 1/16" x 12" SANDED	4
2	FORMERS	1/16" x 1/16" x 12" SANDED	2
3	LEADING EDGE	1/16" x 1/16" x 12" SANDED	2
4	TRAILING EDGE	1/16" x 1/16" x 12" SANDED	2
5	WING RIBS	1/16" SHEET	1
6	WING TIPS	1/16" SHEET	1
7	WING BLOCKS	1/8" x 3/16" x 3"	1
8	TAIL UNIT - FRAME	1/16" x 1/16" x 12" SANDED	2
9	TAIL UNIT - TIPS	1/16" SHEET	1
10	NOSE BLOCK	3/8" x 1/2" x 5/16"	1
11	REAR BLOCK	1/8" x 1/2" x 1/2"	1
12	PROPELLER	1/16" x 5/8" x 7"	1
13	SHAFT	0.08" DIA. x 3" WIRE	1
14	REAR FASTENER	0.08" DIA. x 3" WIRE	1
15	RUBBER	1/32" x 1/8" x 36"	1
16	WASHERS	1/8" O.D.	3
17	WHEELS	3/4" DIA.	2
18	AXELS	LARGE STRAIGHT PIN	2
19	LANDING GEAR	1/16" x 1/8" x 12"	1
20	LANDING GEAR BRACES	OVERS	
21	TAIL SKID	OVERS	
22	TISSUE - RED	SHEET	1*
23	TISSUE - WHITE	SHEET	1
24	CEMENT		1
25	BANANA LIQUID	BOTTLE	1
26	CUTTING TOOL		1

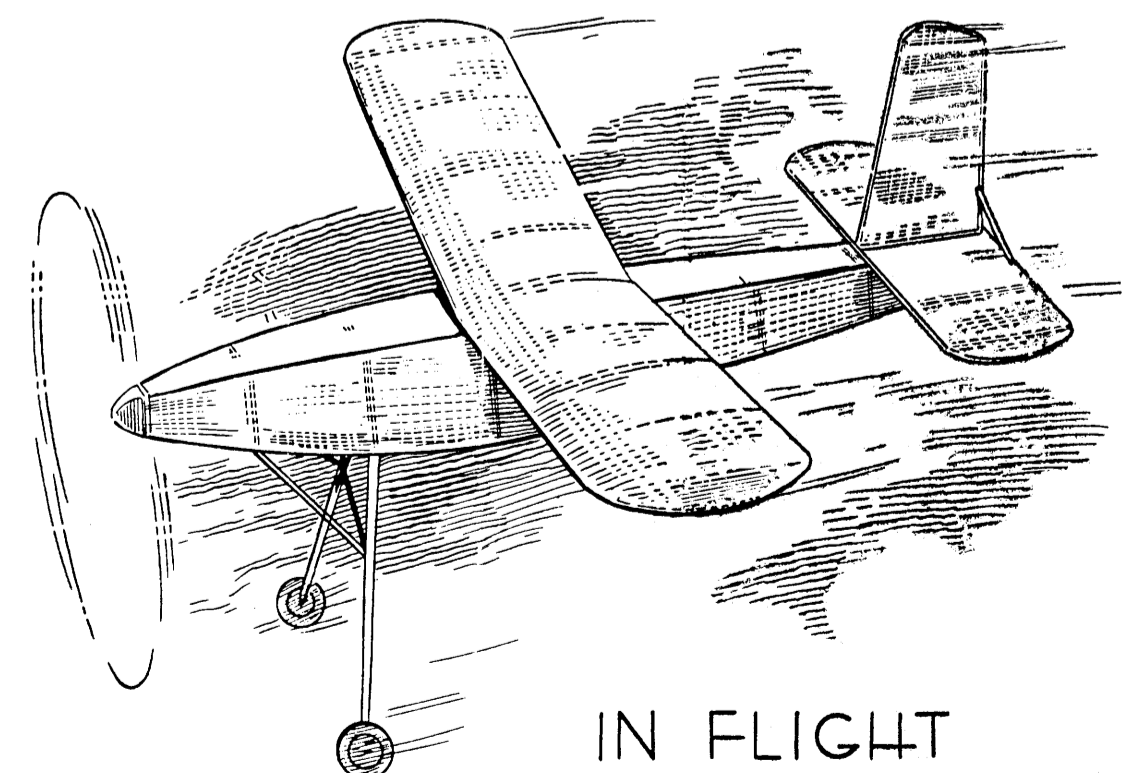
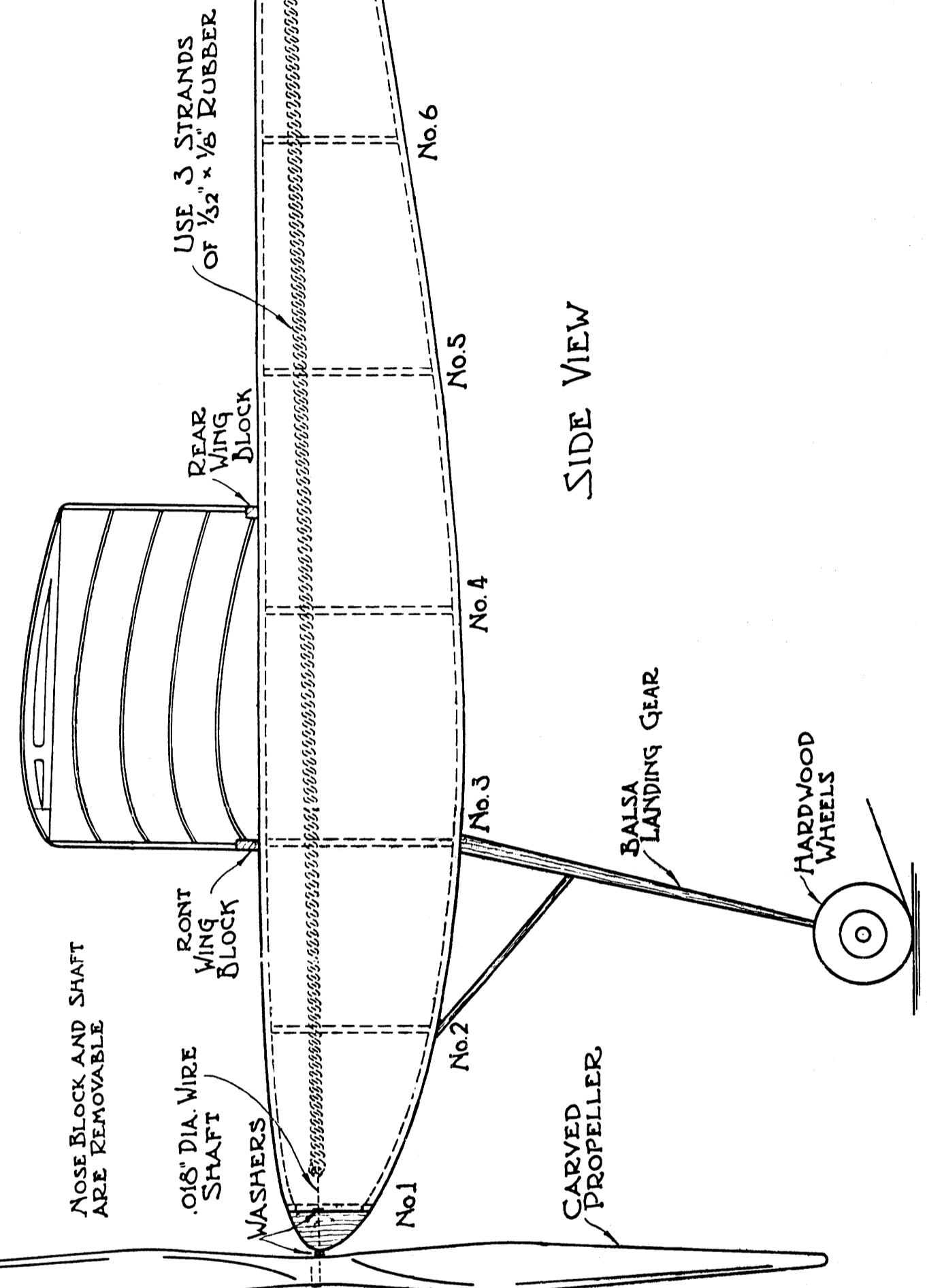
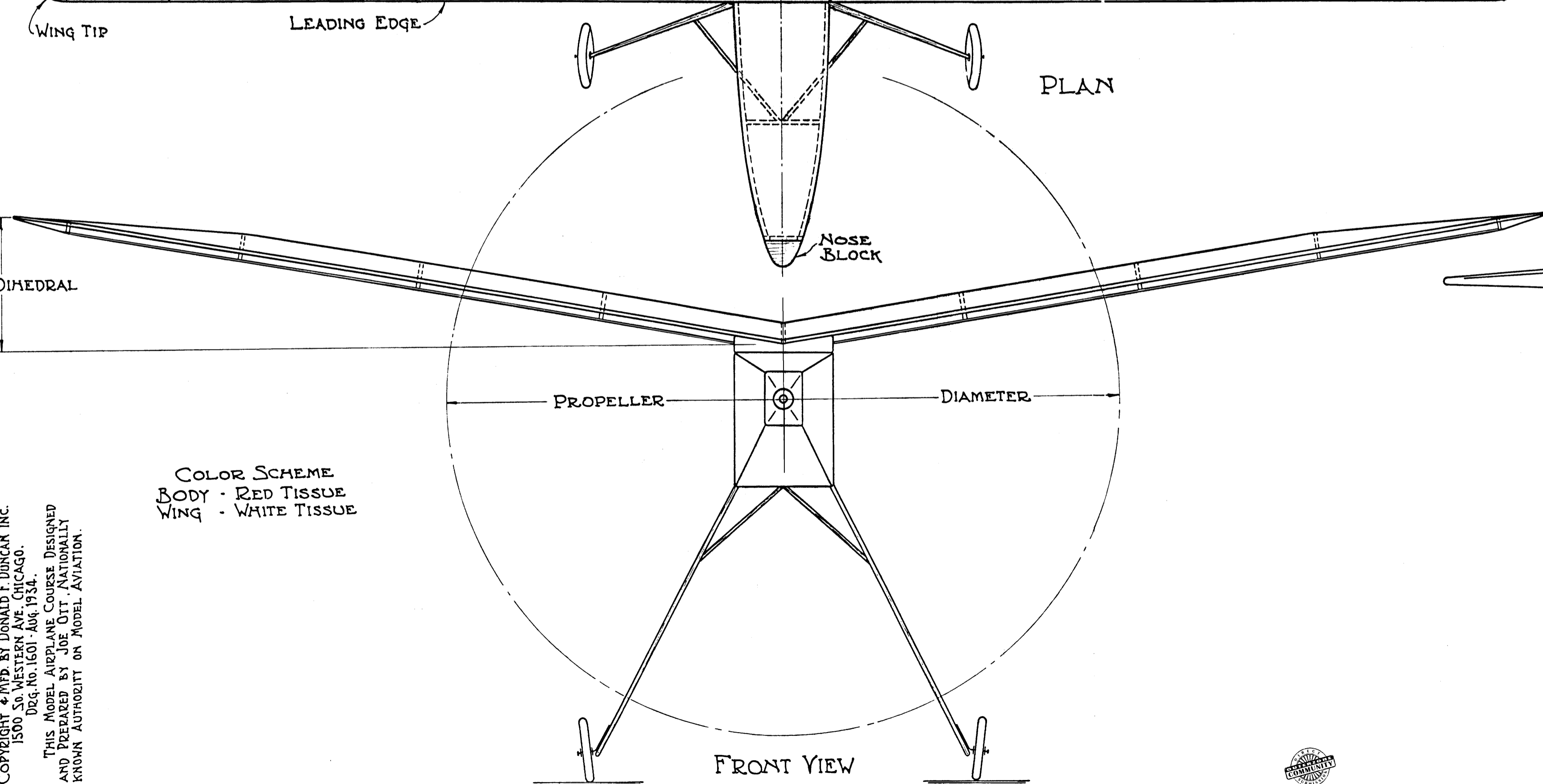
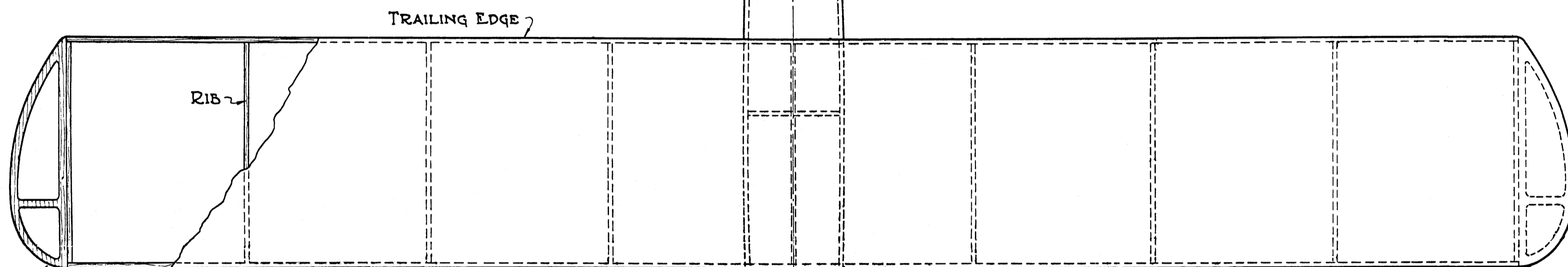
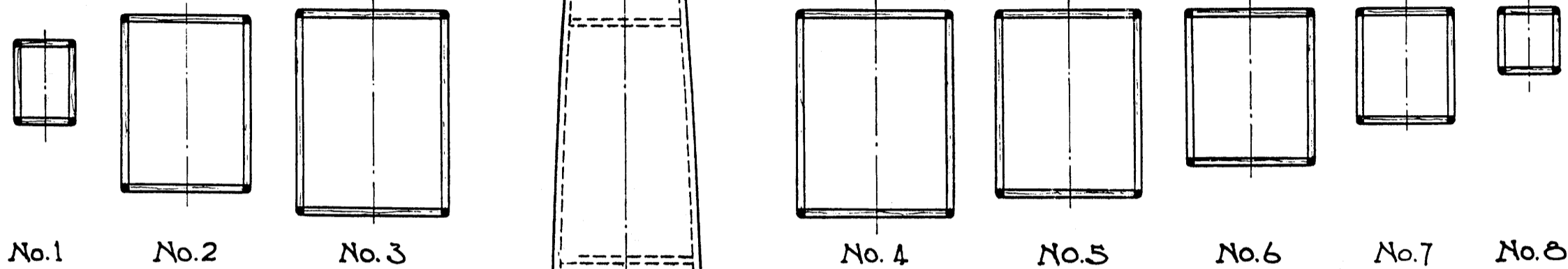
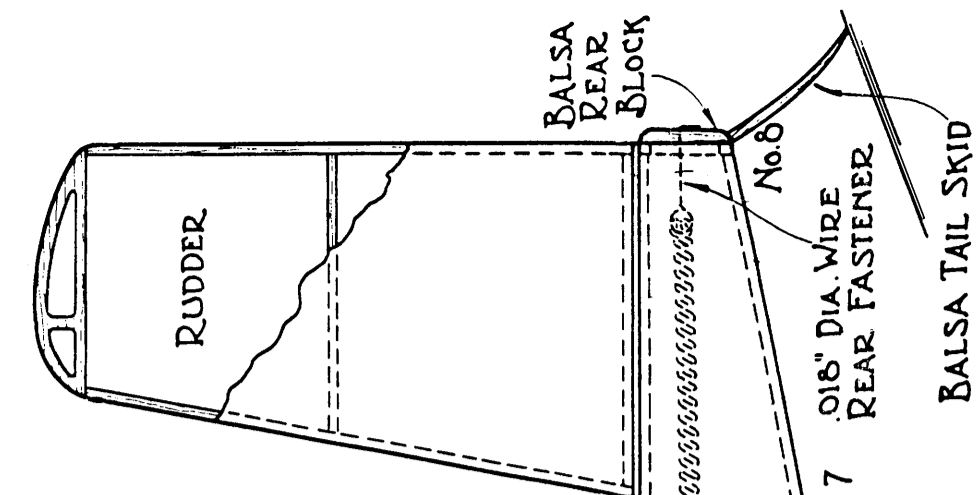
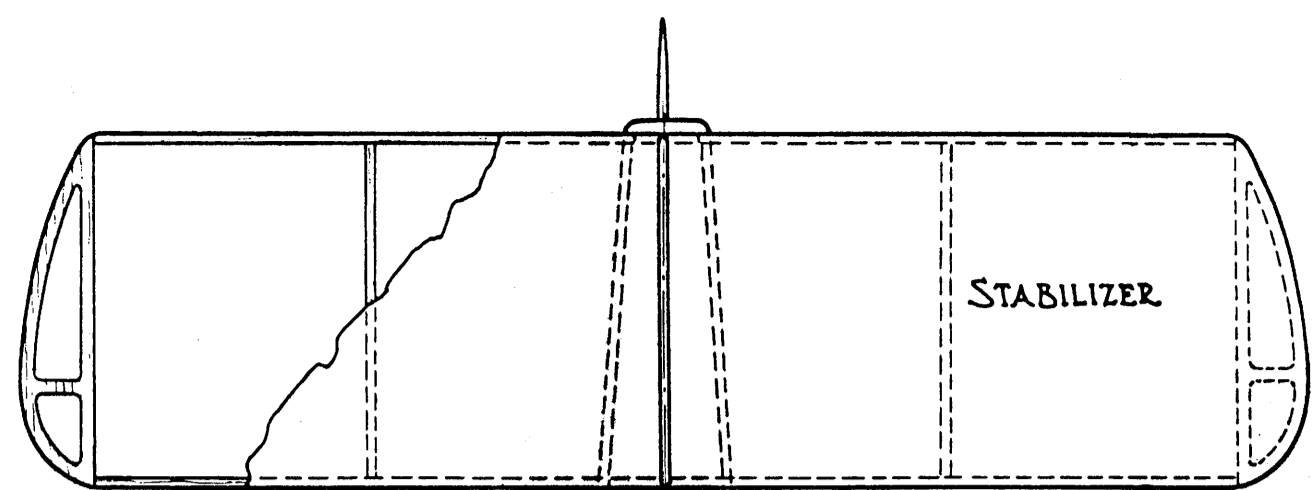

COLOR SCHEME  
 BODY - RED TISSUE  
 WING - WHITE TISSUE

COPYRIGHT & MFD. BY DONALD F. DUNCAN INC.  
 1500 So. WESTERN AVE. CHICAGO.  
 Des. No. 1601 - Aug. 1934.  
 THIS MODEL AIRPLANE COURSE DESIGNED  
 AND PREPARED BY JOE OTT, NATIONALLY  
 KNOWN AUTHORITY ON MODEL AVIATION.

005827  
**INDOOR COMMERCIAL**  
 KIT No. 4 LESSON No. 4 PRIMARY MODEL AIRPLANE COURSE

