

Rubber to keep nose block in place

Glue rudder here (bottom)

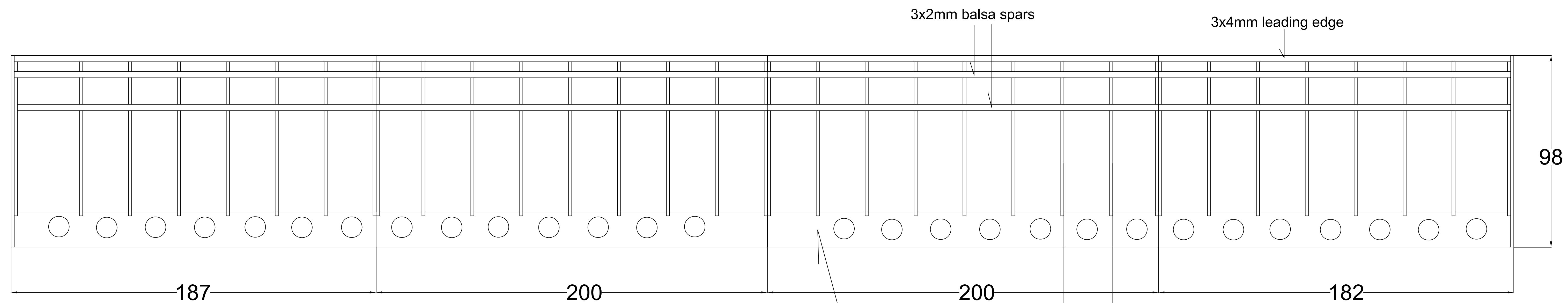

Typical wing rib section

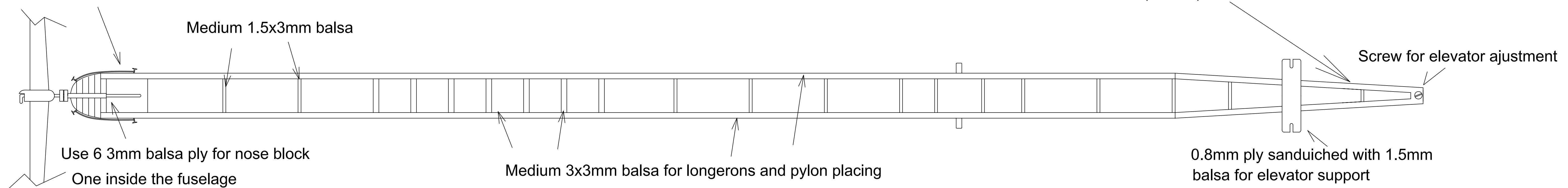
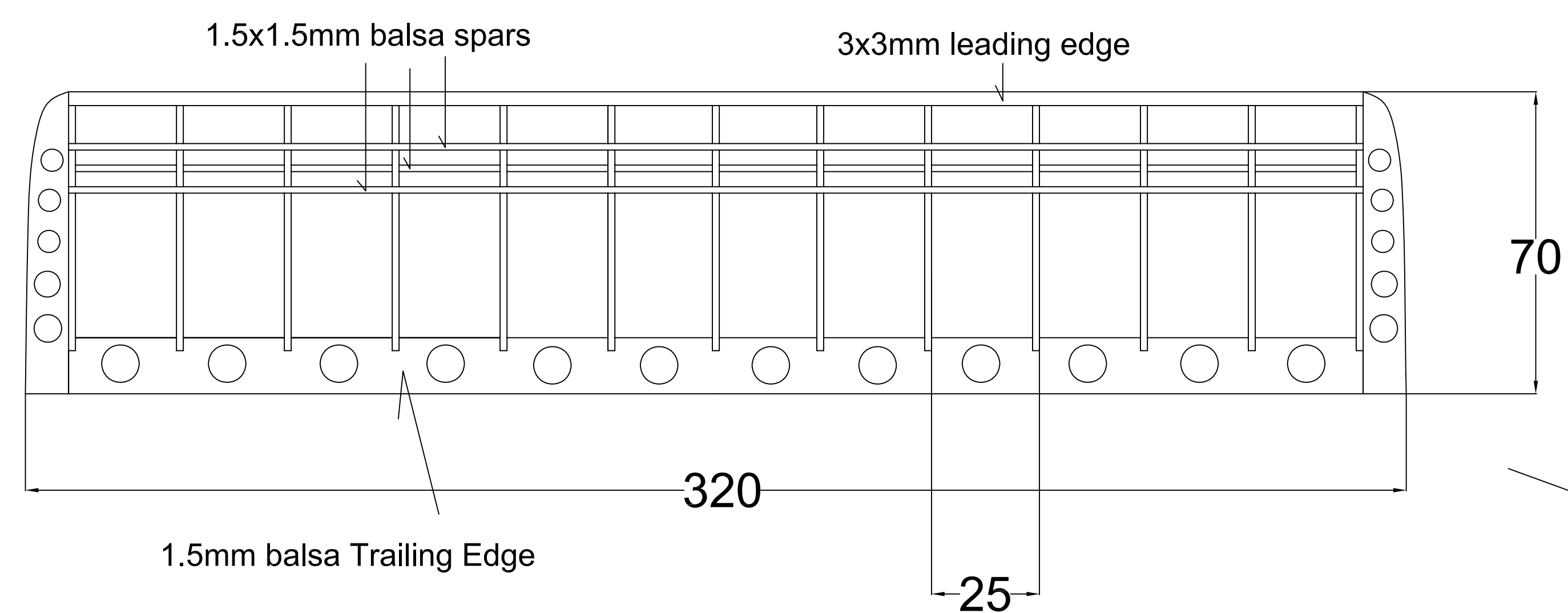
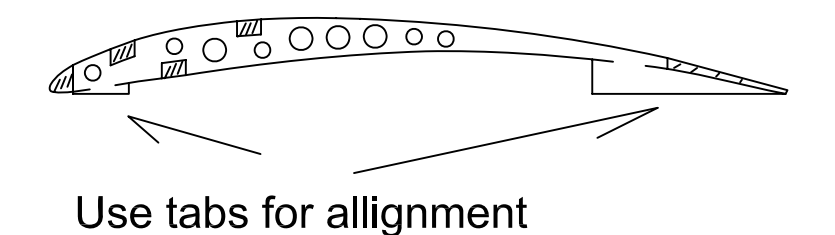

Typical elevator rib section

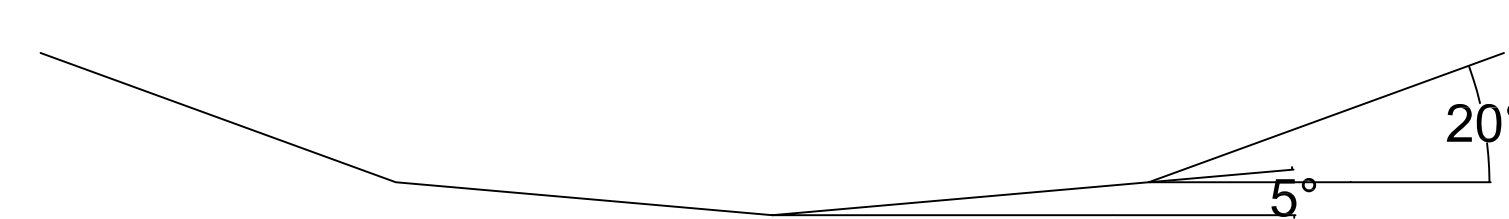
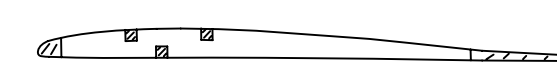

# Saturno V3

Designed by: Alexandre Cruz

2009

alexandrefcruz@gmail.com