

MODEL SHOULD
BALANCE
APPROX.
1/2"
BEHIND
LEADING
EDGE.

DIHEDRAL
5/16"
EACH
WING TIP

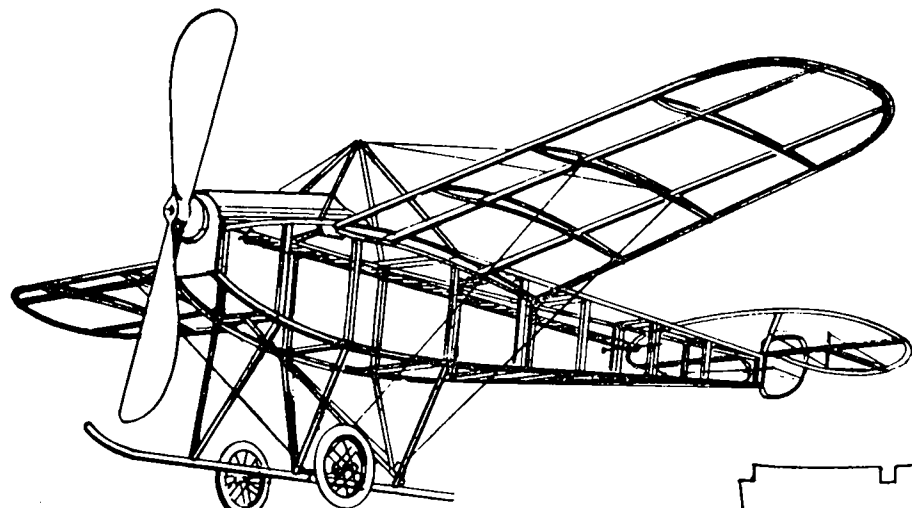
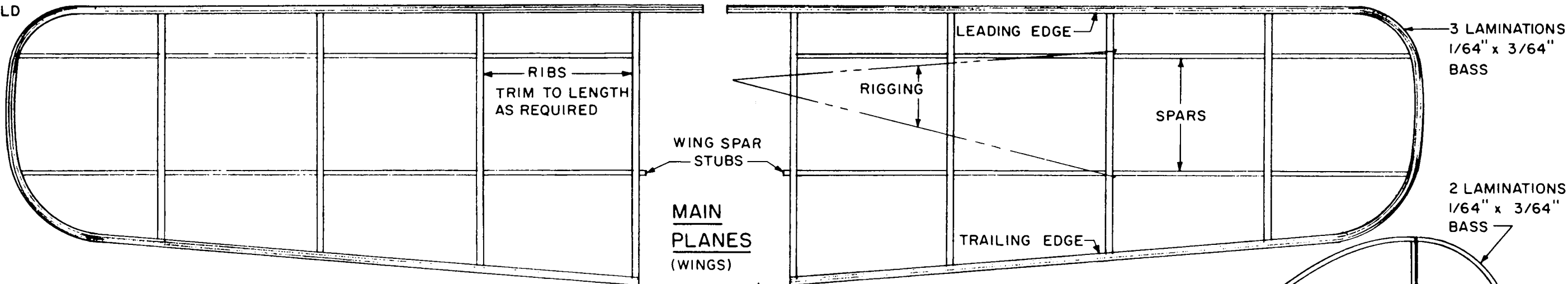

PROTOTYPE
POWER:
2 MM PIRELLI
(ONE LOOP)

THIS MEMBER ON
BOTTOM OF FUSELAGE
ONLY

STABILIZER

STRAIGHT PIN
REAR RUBBER
RETAINER

SKID

VA-OIW
NOSE
BEARING

1/20"
SQUARE

RUDDER
HORN

ELEVATOR

ELEVATOR
HORN

SUGGESTED COLORS:

OVERALL: NATURAL OR BROWN
SPRAY HOOD: ALUMINUM
ALL STRUTS: GRAY

NOTE: ALL
RIGGING
IS SILK
THREAD

**SPRAY
HOOD**
(BOND PAPER)

NOTE GAP
BETWEEN
RIB AND
FUSELAGE

DULL POINT
WITH FILE

WING RIB

2 LAMINATIONS 1/64" x 3/64" OR 1/16" BASS
8 TOP AND 8 BOTTOM MEMBERS REQUIRED

2 LAMINATIONS
1/64" x 3/64"
BASS

1/20"
SQUARE

SPAR 4 REQUIRED. TAPER FROM 3/32" x 3/64" BASS

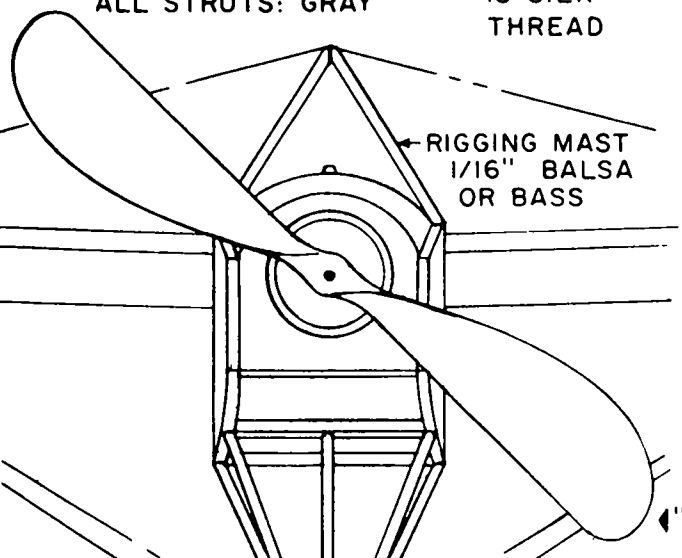

NOSE BULKHEAD
1/16" SHEET
BALS OR BASS

SPRAY HOOD

INSTRUMENT
BOARD 1/16"
BALS OR BASS

RIGGING

OPENING FOR WING SPAR STUB

OPTIONAL RIGGING

RED

WHITE

BLUE

RUDDER

1/16" OR 1/20" SQUARE
BALS OR BASS STRUCTURE
(TYPICAL)

FUSELAGE

THRUST
WASHERS

TWO
UPRIGHT
MEMBERS

1/16" SHEET

RIGGING

WARP
CONTROL
ROD

WARP CONTROL
ARM
(CARD STOCK)

VERY HARD
1/16" BALS
OR BASS
SANDED
ROUND



AXLE .025 MUSIC WIRE

SKID
1/16" DIAMETER REED

WHEELS WHITE TIRES
VA-63W (HUNGERFORD) OR VA-50 CW

"IDEAL" NIEUPOORT SCOUT PEANUT
13 INCH FLYING MODEL
AN ADAPTATION OF THE 1913 DESIGN, BY BILL HANNAN

COPYRIGHT MCMLXXIV VINTAGE AERO
1 THE GLEN • TENAFLY, NEW JERSEY 07670