

PARTIES BRÈES COFFRAGE Balsa 0.4 mm

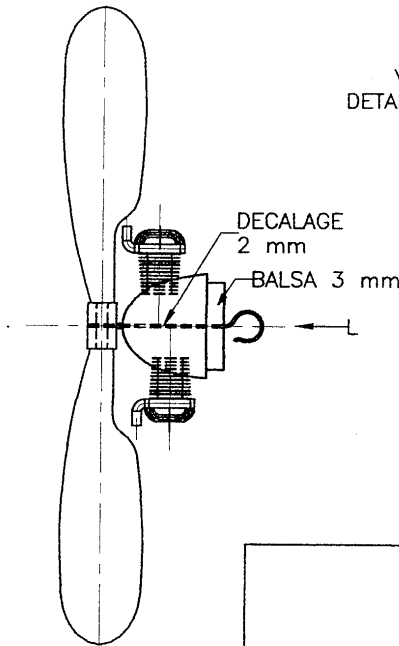

VUE Suivant L

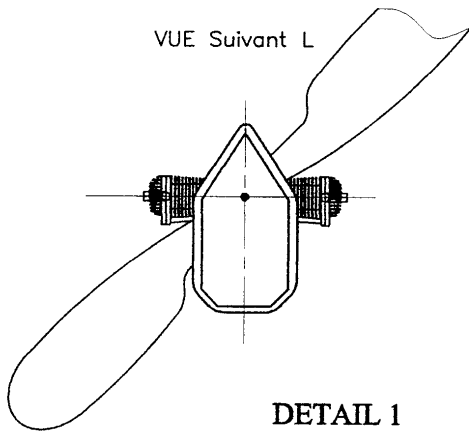

DETAIL 1
ESSIEU TRAIN
D'ATTERRISSAGE

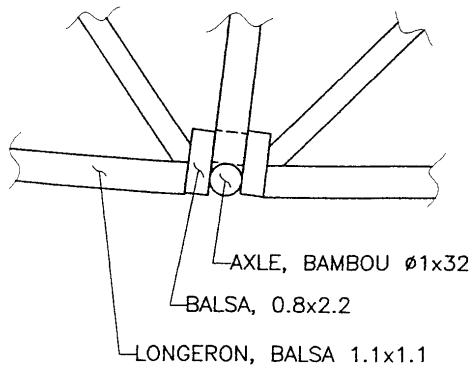

COULEUR:

ZONES OMBRÈES: BOIS VERNIS
AUTRES ZONES: TOILE COULEUR NATURE
CAPOT MOTEUR: ALUMINIUM POLI

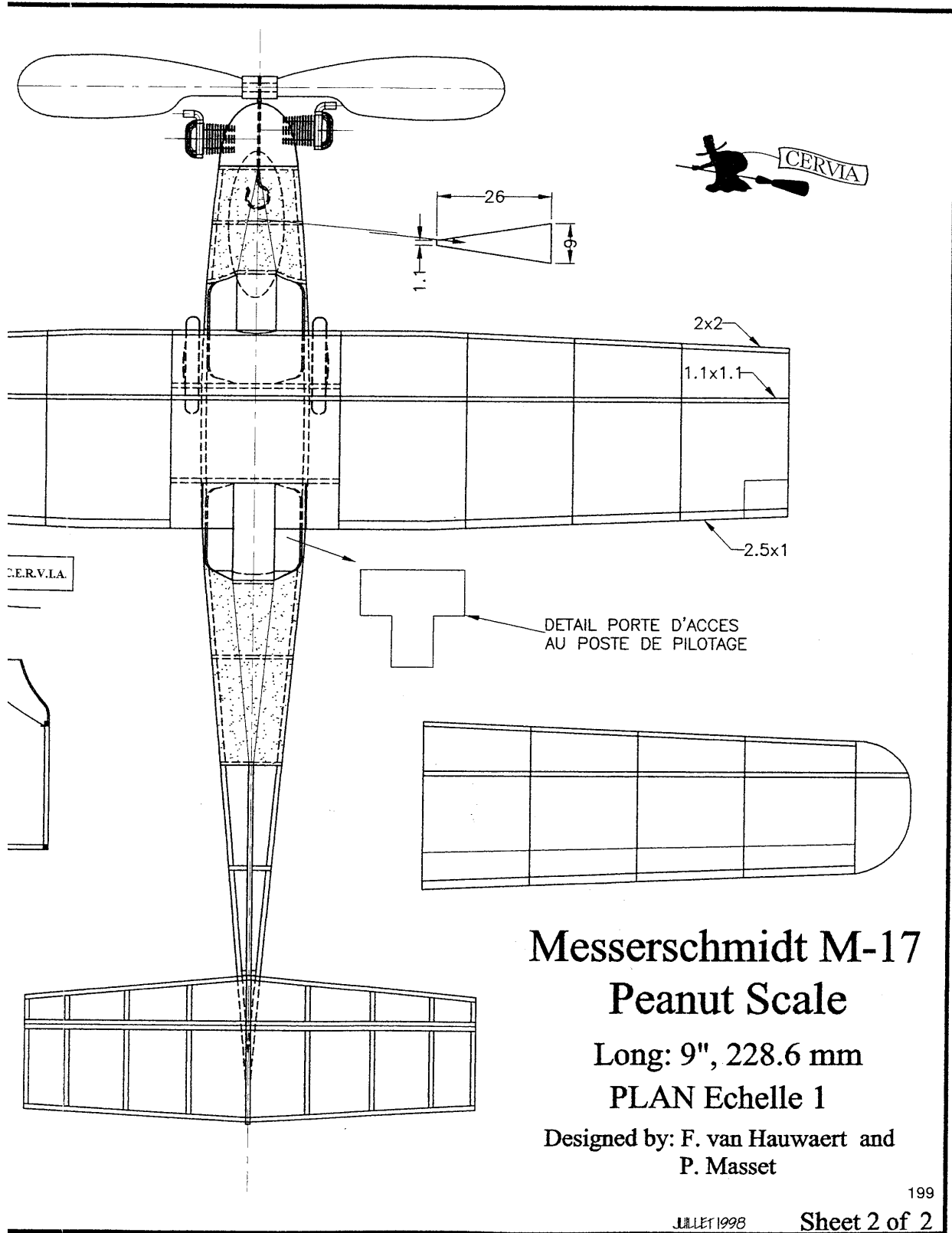

Messerschmidt M-17 Peanut Scale

Long: 9", 228.6 mm

PLAN Echelle 1

Designed by: F. van Hauwaert and
P. Masset

DETAIL 2

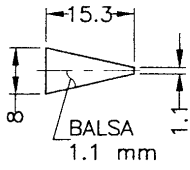

VUE K

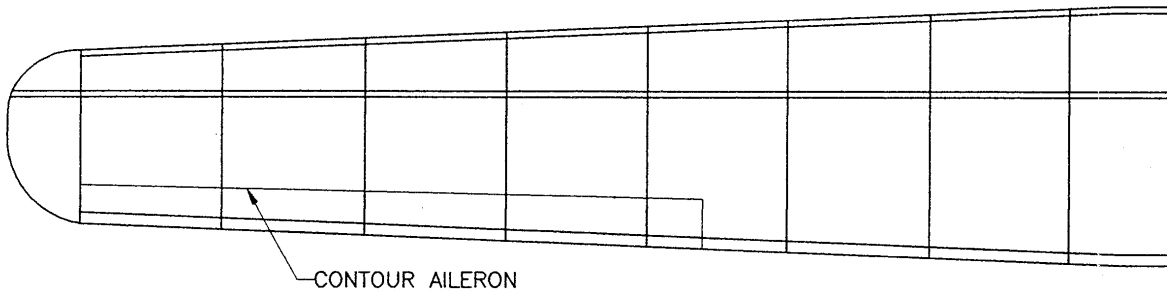
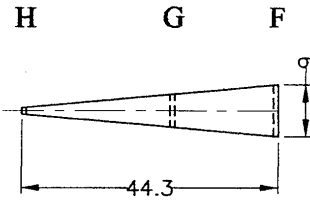

LES SAUVAGES BY C.E.R.V.I.A.

A

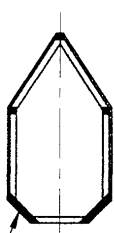

VOIR DETAIL 2

B

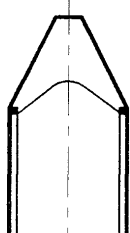

C

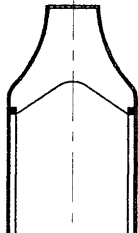

D

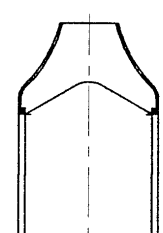

E

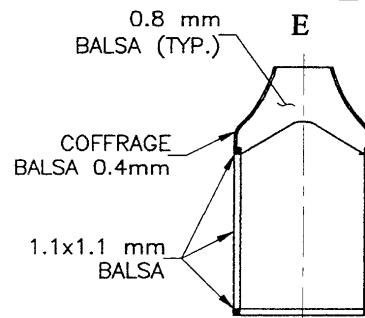

F

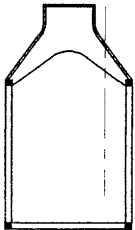

G

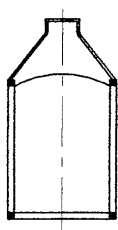

H

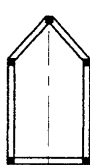

I



J



BALSA 1 mm
mis en forme
sur un cylindre
de Ø80 et avec
une inclinaison de
15°

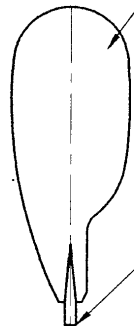

BAMBOU Ø2 mm

