

McCOMBS FB40-9 AIRFOIL
 L.E. 1/20 sq.
 T.E. 1/32 x 3/32.
 Spars 1/32 sh. strips.
 Ribs 1/32 sq. top & bottom.
 L.E. 1/64 sh. top.
 Tips 3 laminations 1/64 x 1/20.

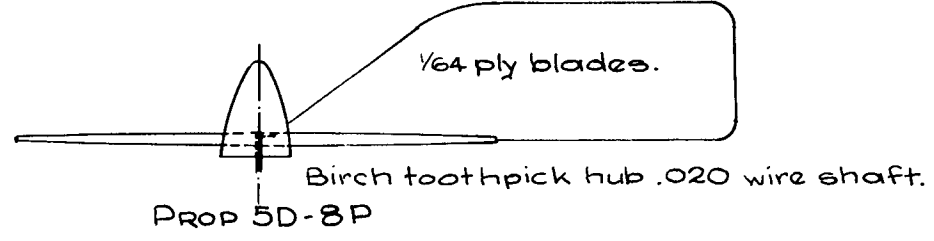

This is a modified stock 1938 model Taylorcraft by Duane Cole for aerobatics. Principal changes are a new wing with a 7-foot shorter span and a slightly larger cowl to enclose a 150 h.p. Lycoming engine.
 Colors: Red - Bottom wing & stabilizer surfaces, fuselage nose back to scallops, top of wing, stabilizer & rudder scallops, top & bottom of fuselage, landing gear & fuselage letters.
 White - Spinner & remainder of aircraft.
 Black - Tail numbers & top cowl anti-glare panel inside windshield.

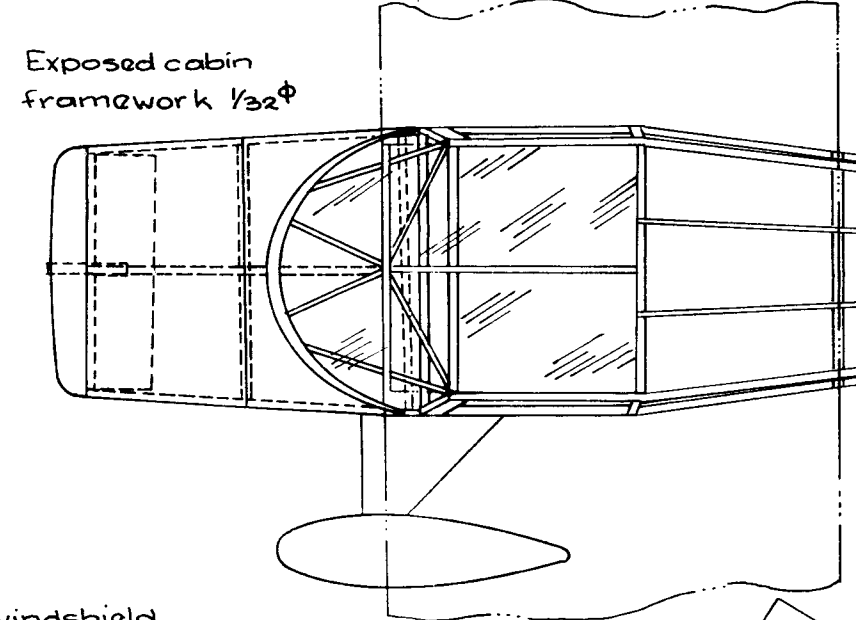

TAIL SURFACES:
 Outlines 2 or 3 laminations 1/64 x 1/20.
 Spars & ribs 1/20 sq. Trim tab vanes 1/32.

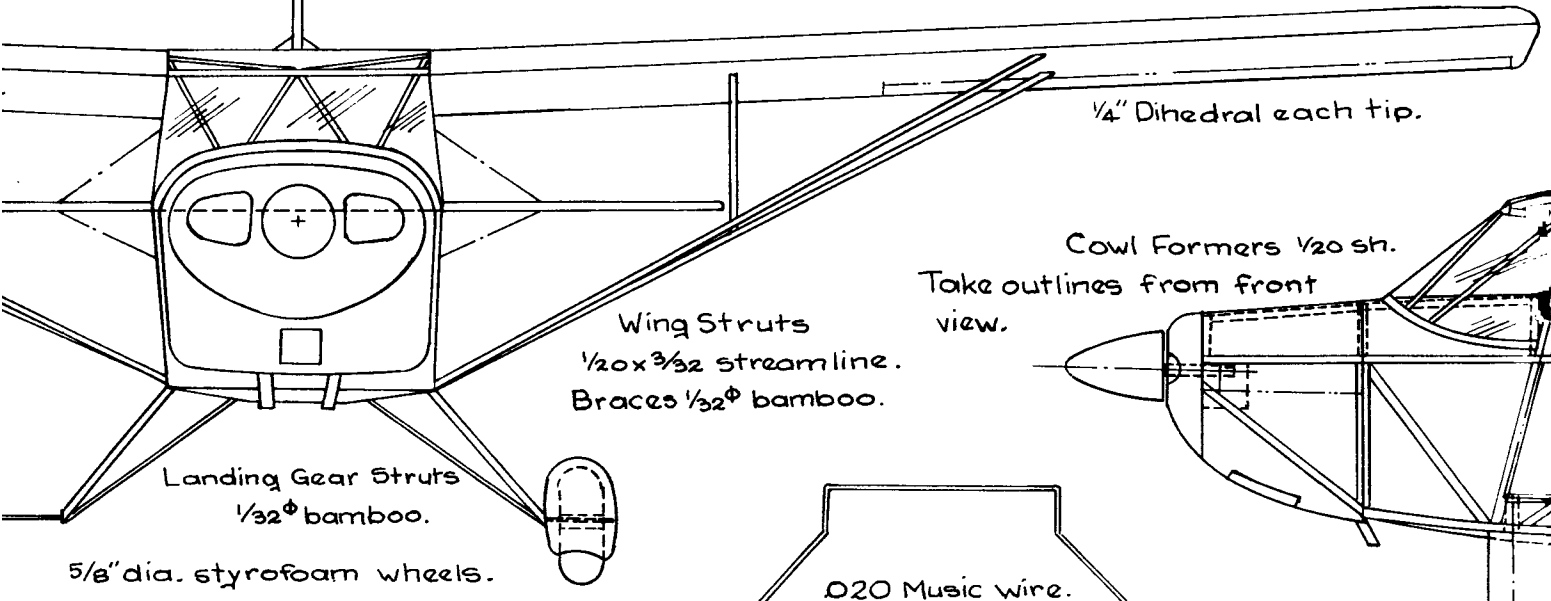
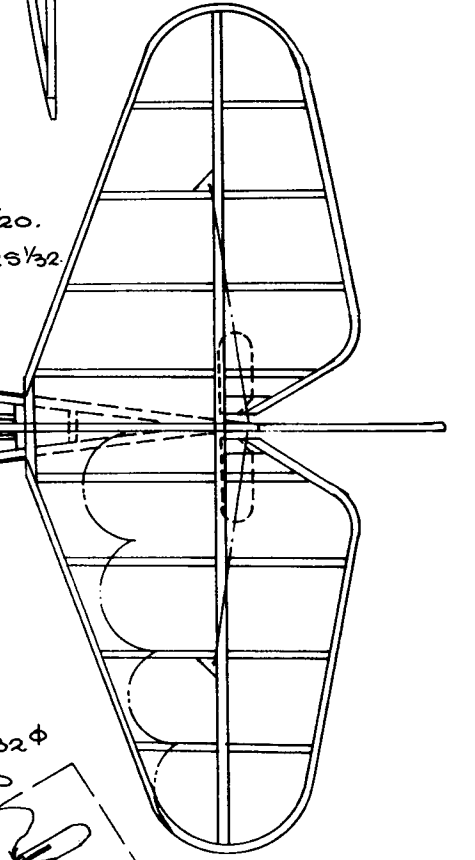

FUSELAGE:
 Basic frame 1/20 sq, stringers 1/32 sq.
 Cowl top & sides 1/64 sh. Noseblock & cowl bottom styrofoam. Vacuum wheel covers & epinner.

Cowl Formers 1/20 sh.
 Take outlines from front view.

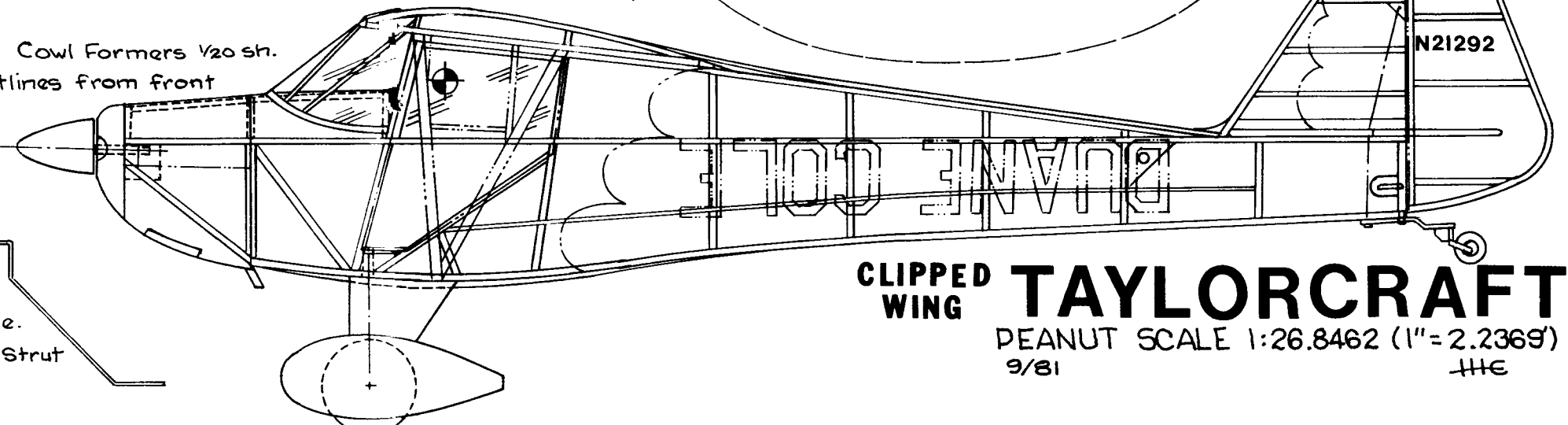
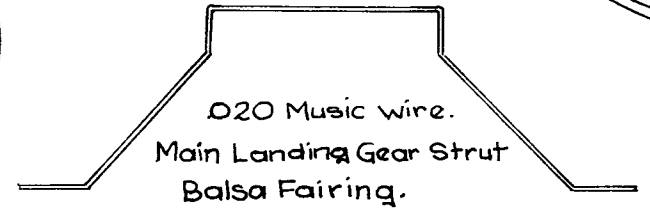

CLIPPED WING TAYLORCRAFT
 PEANUT SCALE 1:26.8462 (1" = 2.2369")
 9/81 HHC