

STANDARD SEA FURY VERTICAL STAB

SUPER SEA FURY TAIL WITH P&W R-4360 ENGINE

SLICED RIBS PATTERNS TRIM FROM THE TRAILING EDGE FOR SHORTER RIBS... MAKE FROM 1/16 Balsa SHEET

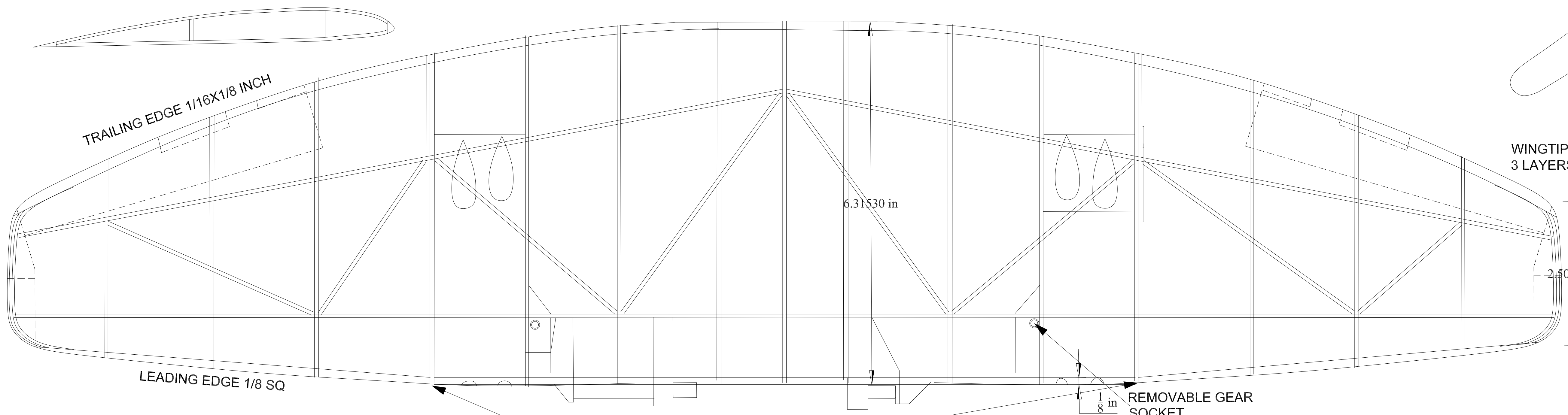
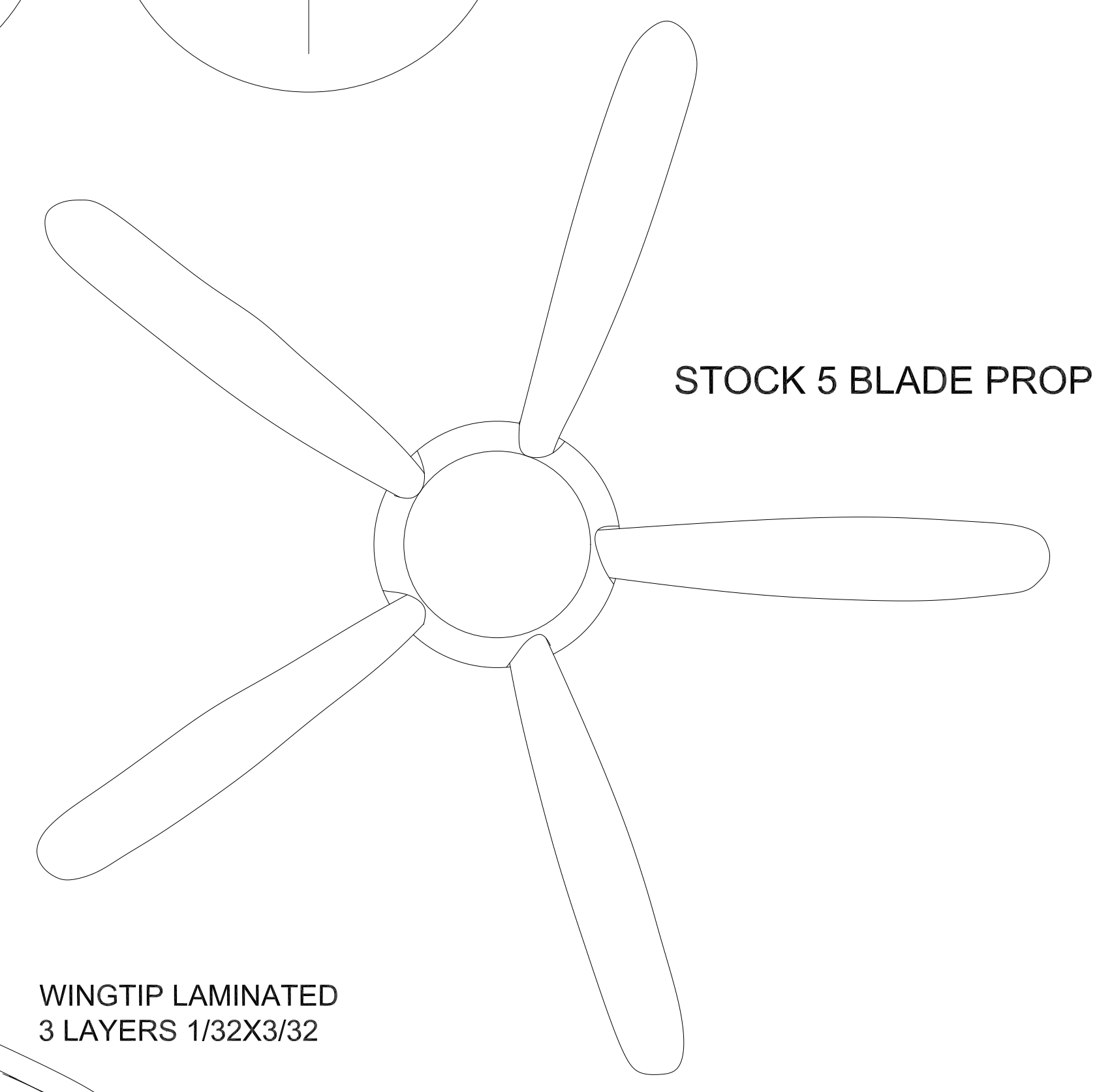
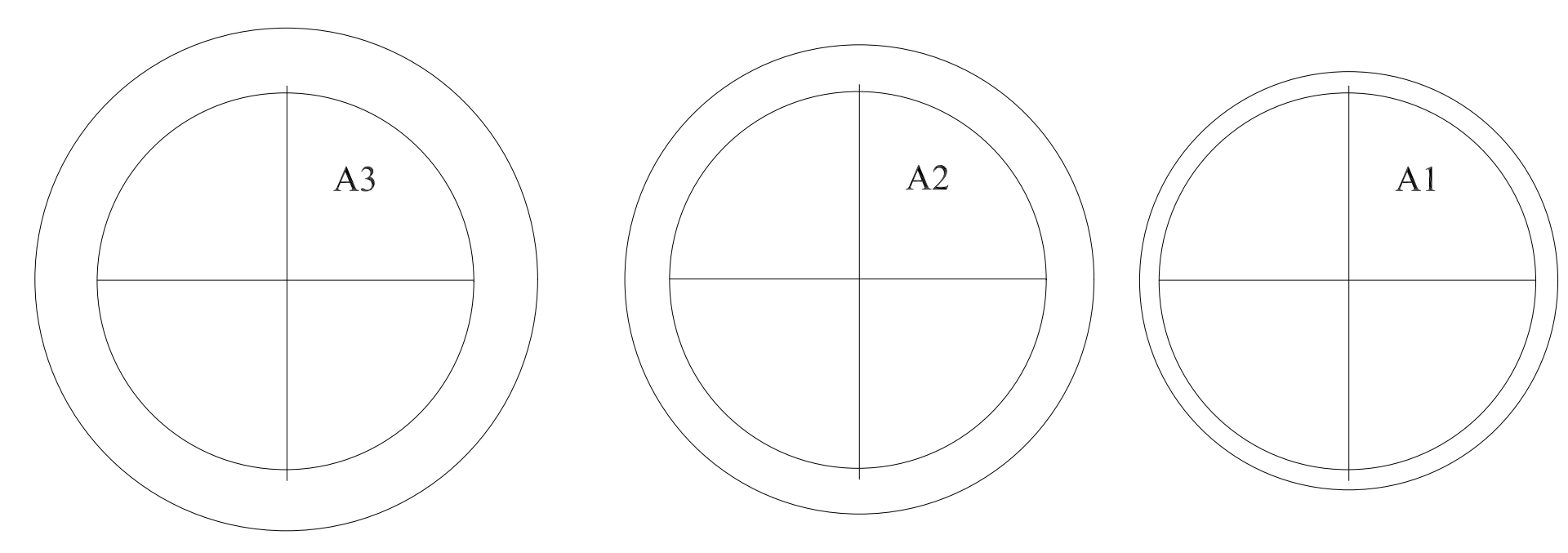
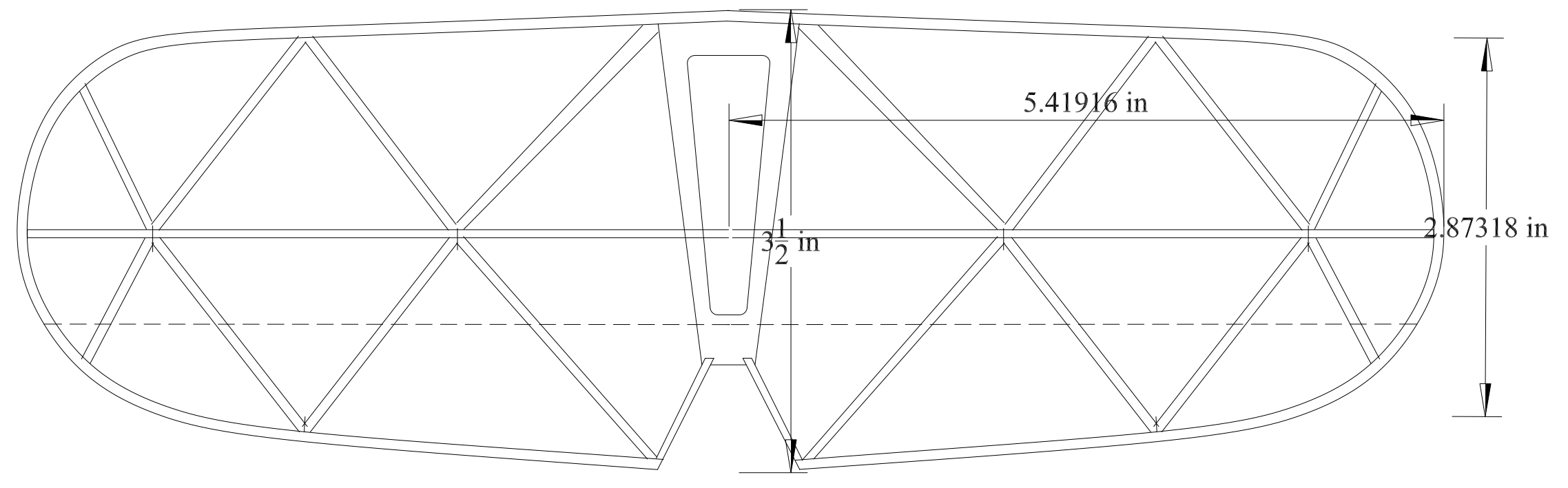
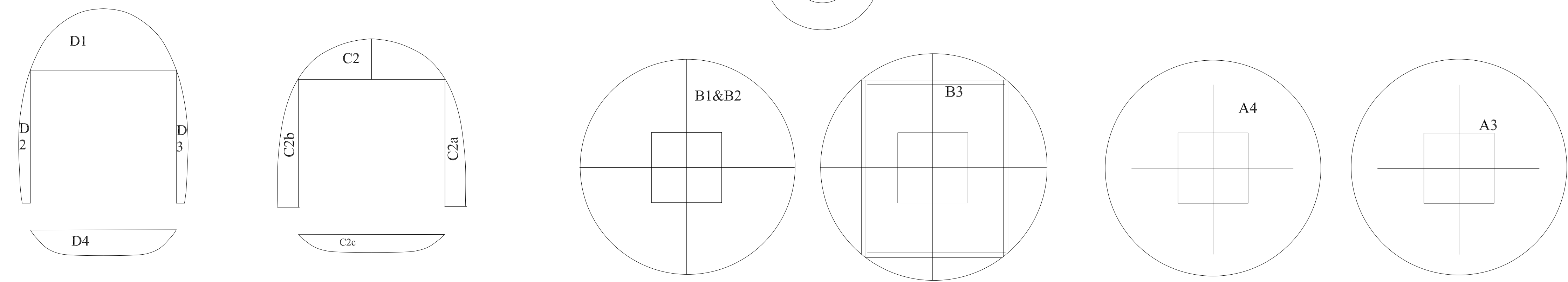
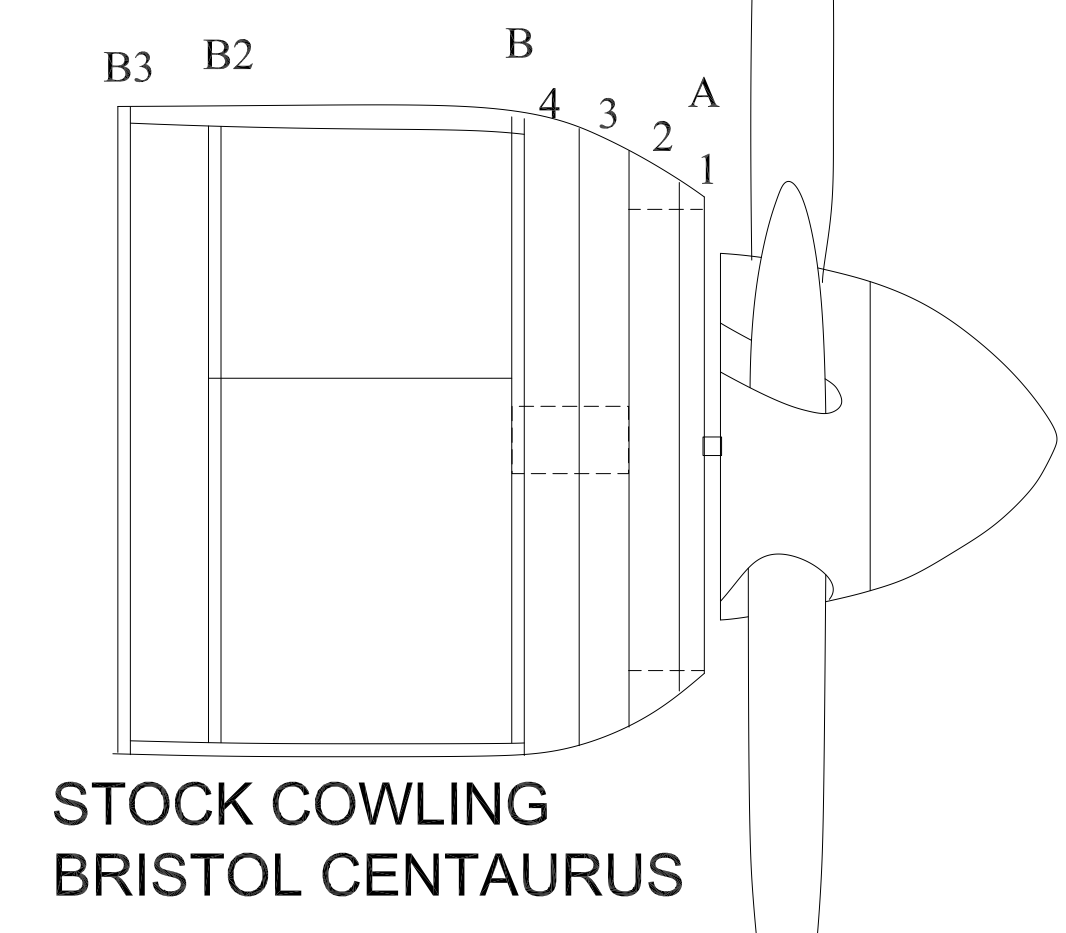
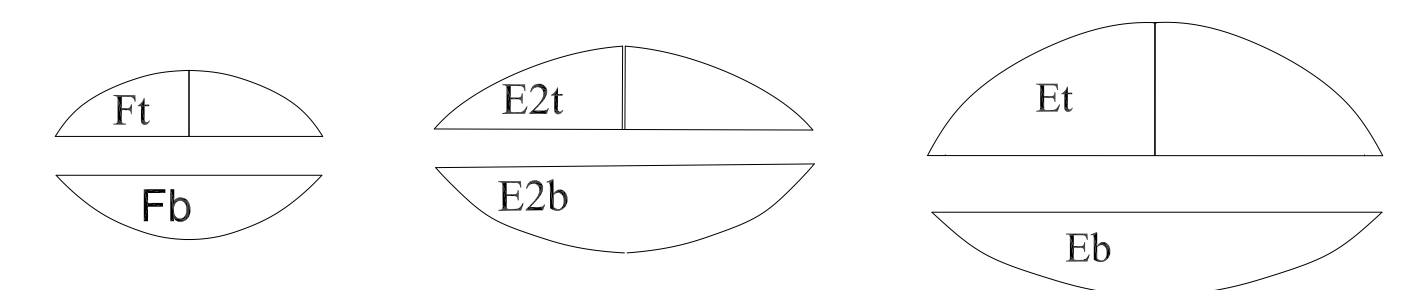
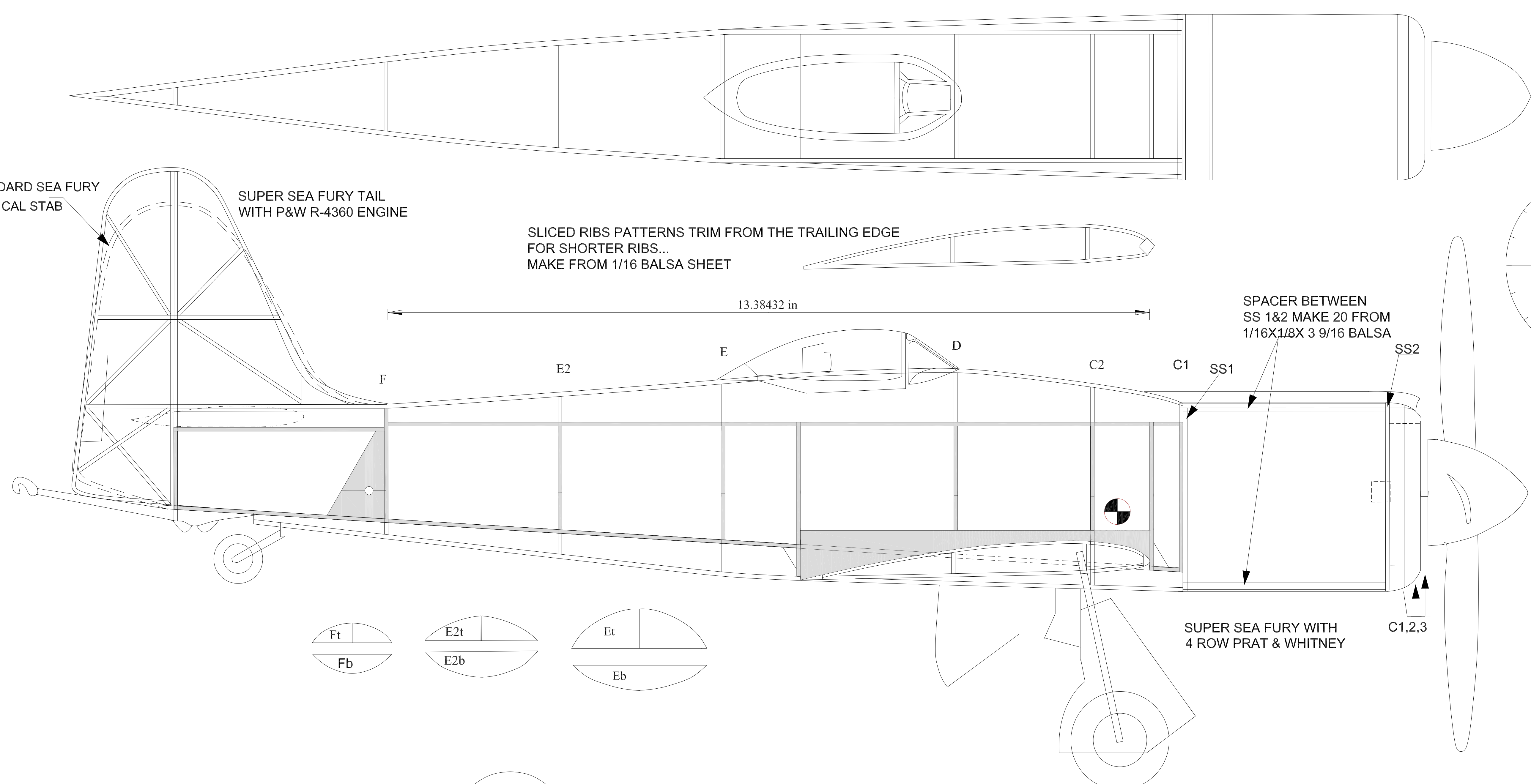

WINGTIP LAMINATED 3 LAYERS 1/32X3/32

1.5" UNDER EACH WINGTIP

HAWKER SEA FURY

SUPER SEA FURY WITH R- 4360 PRATT & WHITNEY

SPAN 27" 1/17 SCALE DATE: 1 FEB 2015

DESIGNED/DRAWN BY: **TOM AKERY**

NOT FOR RESALE DRAWN FROM 3-VIEW

FREE USE FOR MEMBERS OF S&T, HPA & SFA