

Fisher P-75A

27" SPAN RUBBER POWERED MODEL
 DRAWN/DESIGNED BY TOM AKERY
 15 SEPT 2019 FREE USE FOR S&T, HPA
 & SFA MEMBERS
 OPTIONAL CONTRA-ROTATING PROPS

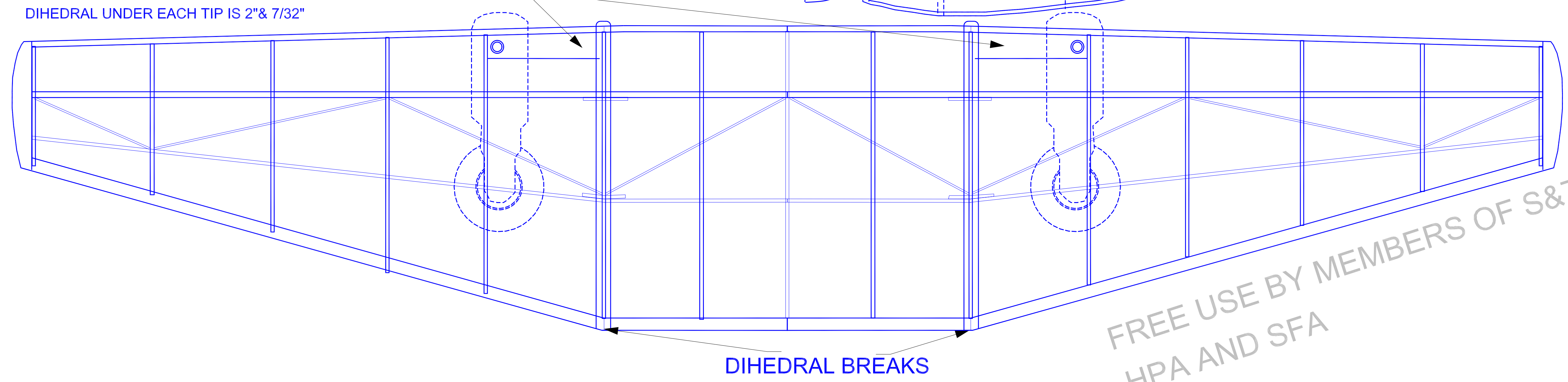
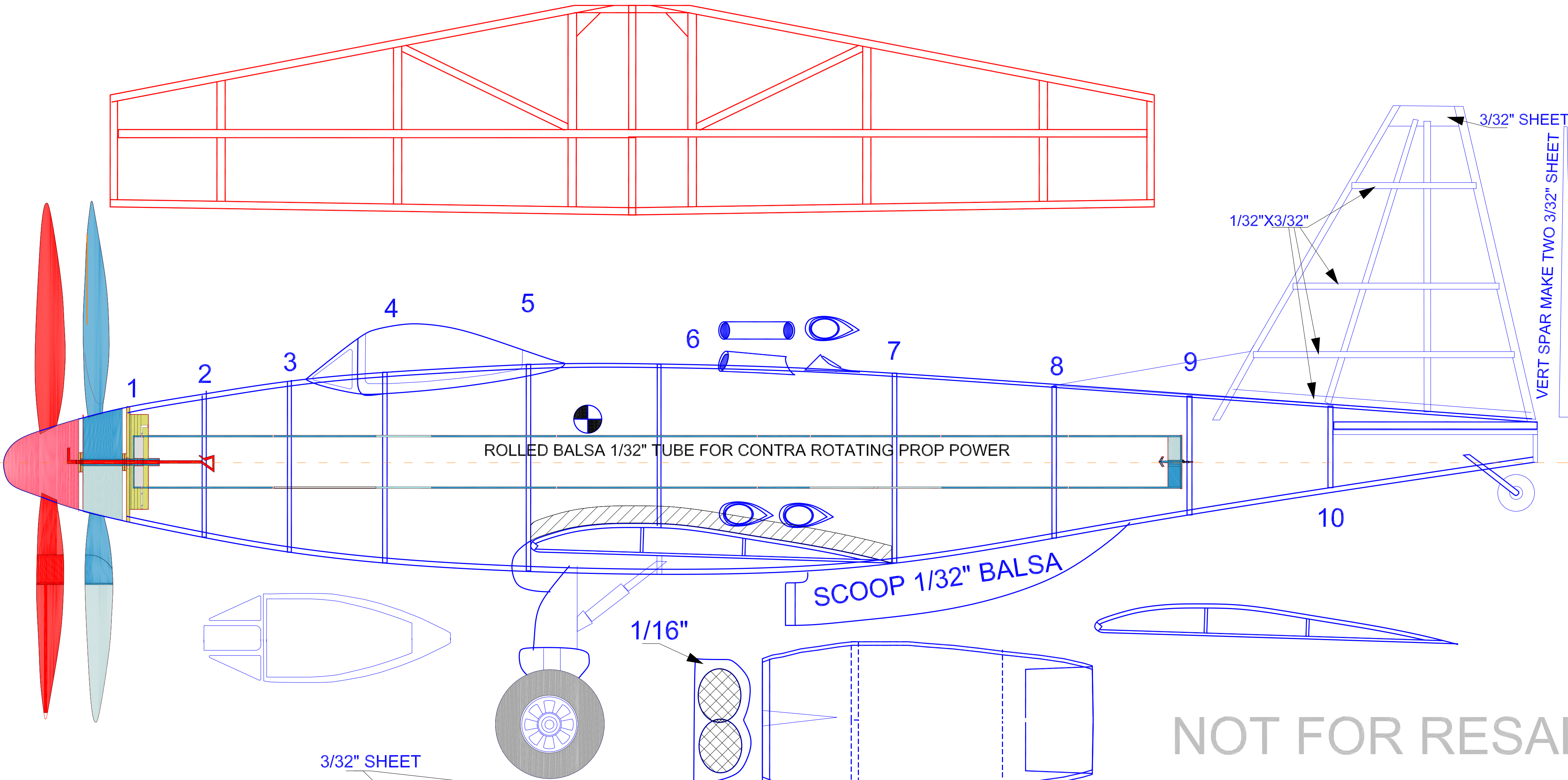

FREE USE BY MEMBERS OF S&T,
 HPA AND SFA

NOT FOR RESALE

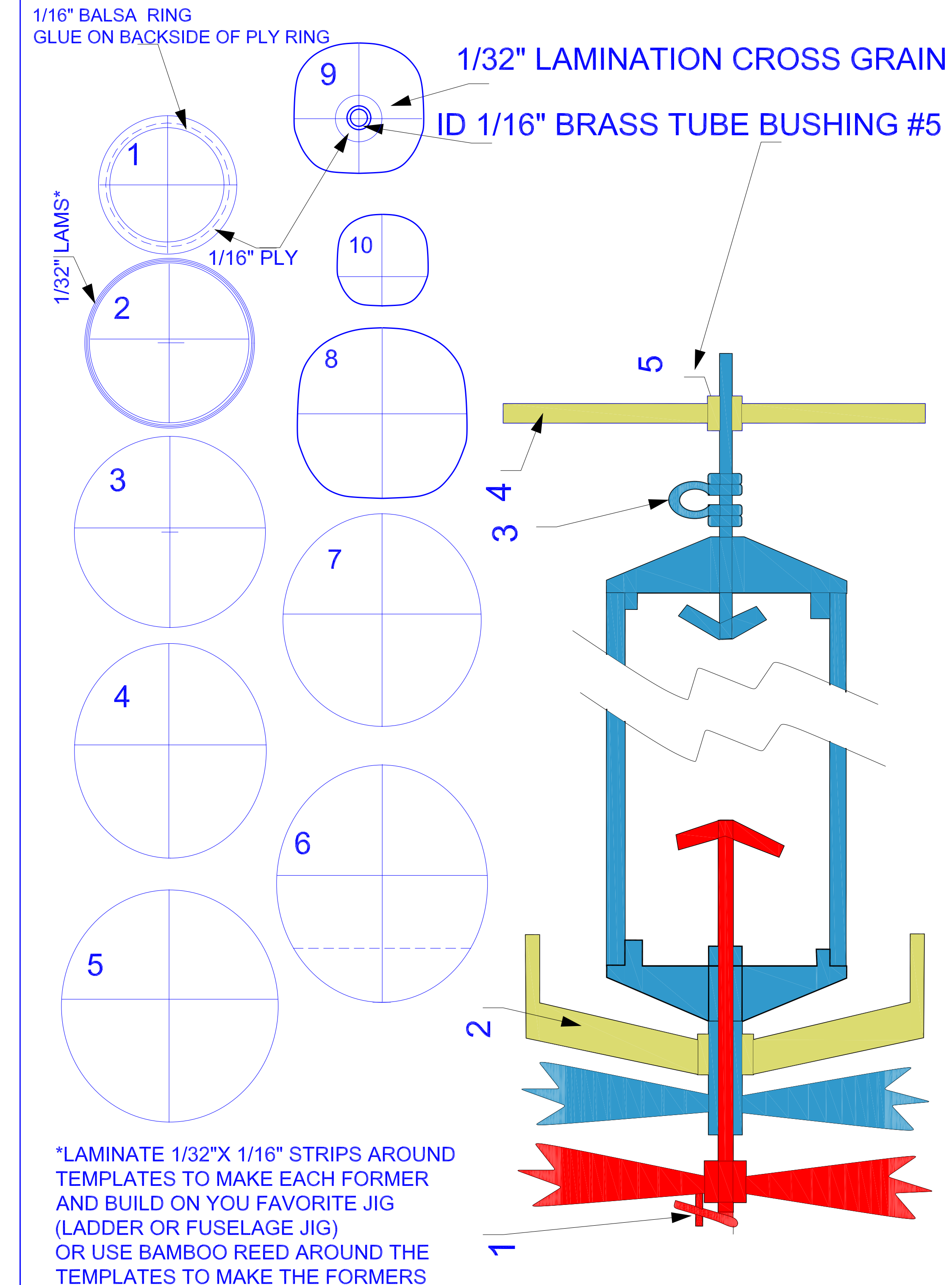

*LAMINATE 1/32\"/>

1. FREE WHEEL DEVICE
 2. NOSEBLOCK PROP BEARING
 3. MOTOR ANCHOR HOOP
 4. FUSELAGE FORMER
 5. BRASS TUBE BUSHING REAR MOTOR MOUNT
- GOLDEN COLOR IS FIXED OR CLIPPED INTO THE FUSELAGE - RED SPINS ONE WAY
 BLUE SPINS THE OPPOSITE OF RED.