

THE KI-77 WAS THE JAPANESE ARMY AIRFORCE DESIGNATION FOR THE A-26, a clean, slim low-wing, twin-engine monoplane intended for an endurance flight between New York and Tokyo. The A stood for the name of the sponsor, a newspaper Asahi Shimbun which was vying for records with a rival paper that had sponsored the Mitsubishi Ki-15 Kamikaze flight to the United Kingdom in 1937. 26 was for the 26th century of the Japanese Imperial Dynasty - 1940 was year 2600 in the Japanese calendar.

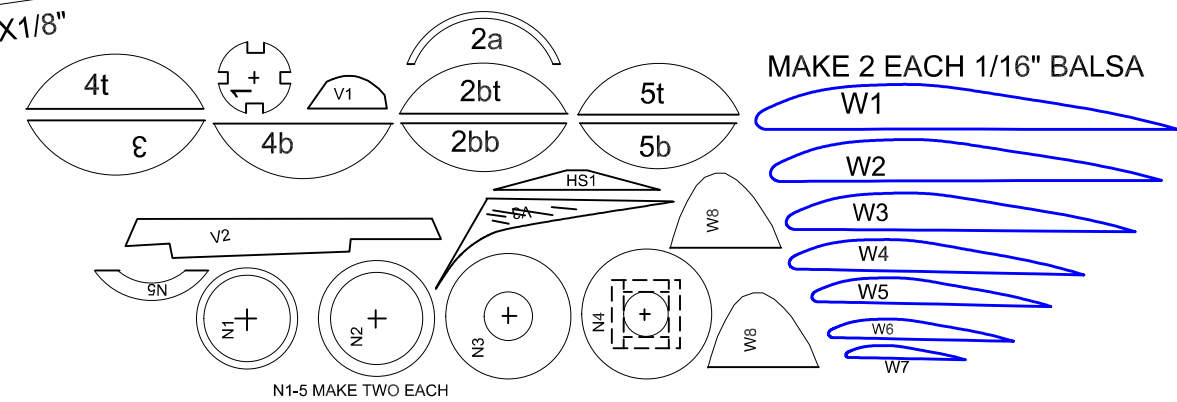
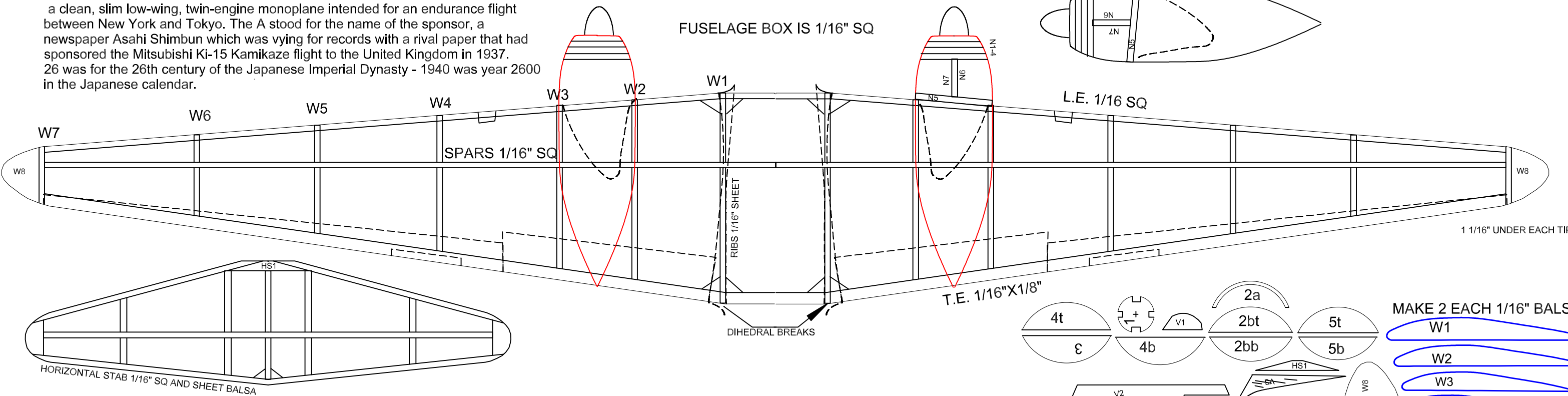

TACHIKAWA KI-77

16" SPAN PSEUDO-DIMER
 DESIGNED BY TOM AKERY 24 MAY 2022

CHECK OUT stickandtissue.com,
FreeFlightArchives.com
hippocketaeronautics.com