

NOTE:
FORMERS 1 & 5
CONSIST OF TWO
LAYERS OF 1/8" SHEET
CROSS GRAINED

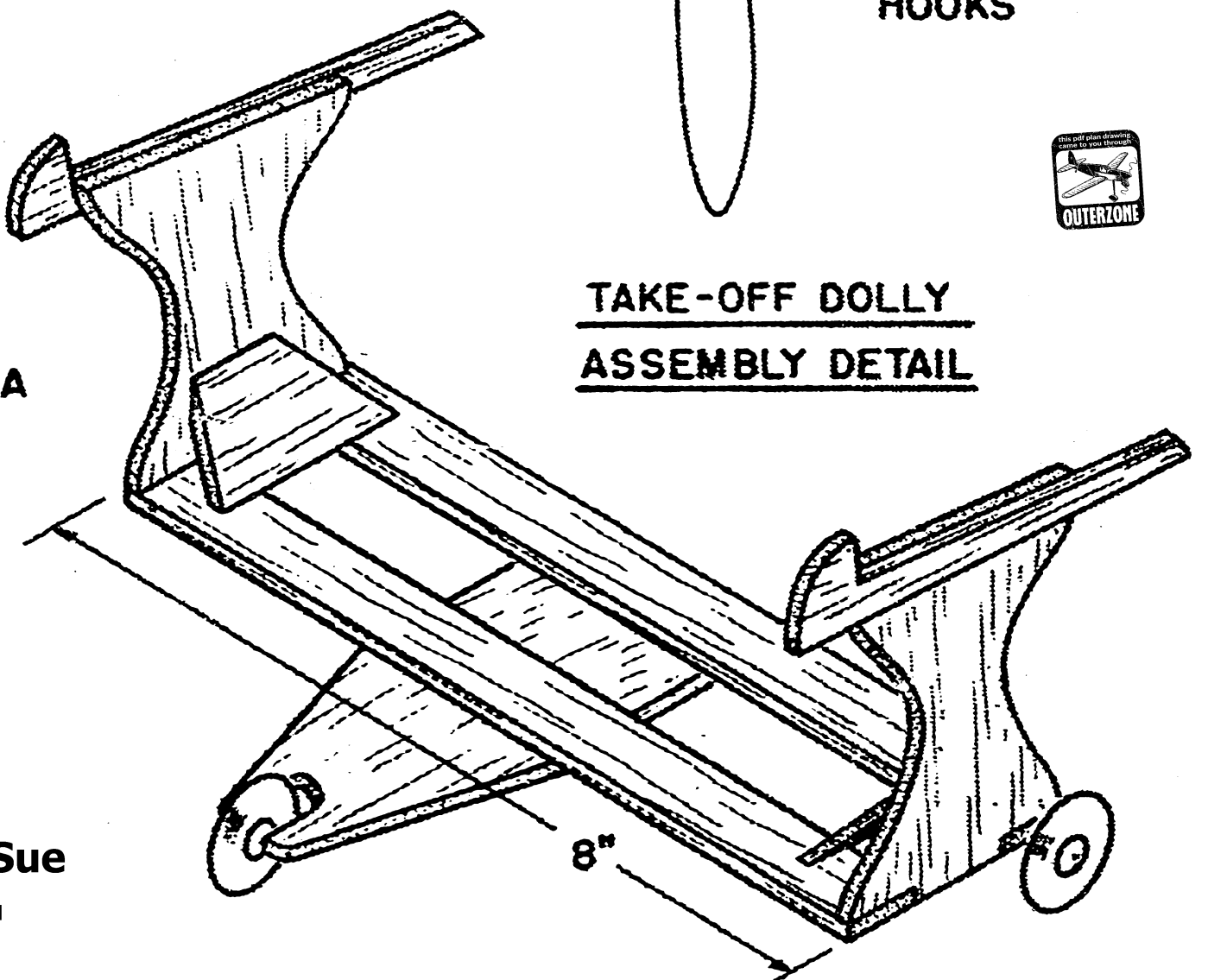
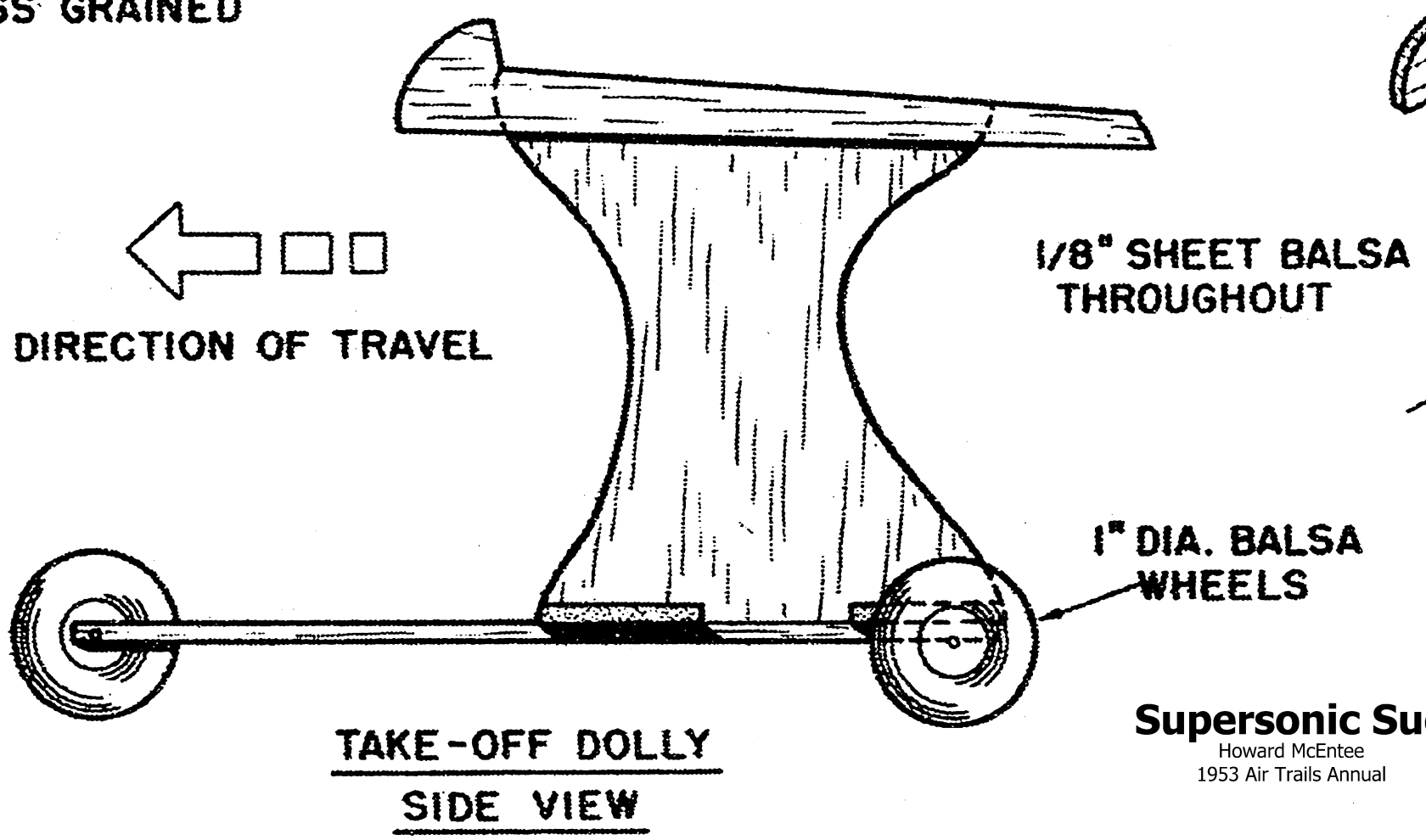

Supersonic Sue
Howard McEntee
1953 Air Trails Annual

PLANS TRACED BY A. KOCHMAN