

Prop blades use 1/32" sheet sanded very thin. Hub uses 1/8" hard balsa with brass tube for spinner.

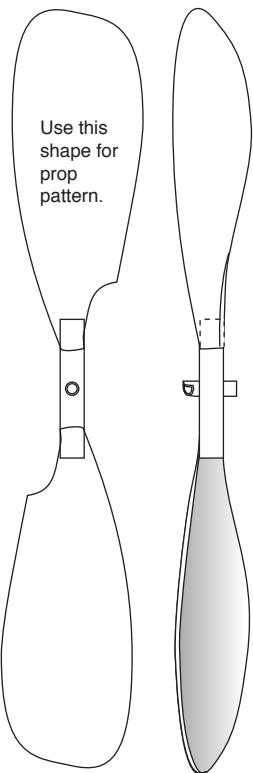

1/32" plywood with soft balsa block for nose inset and cone.

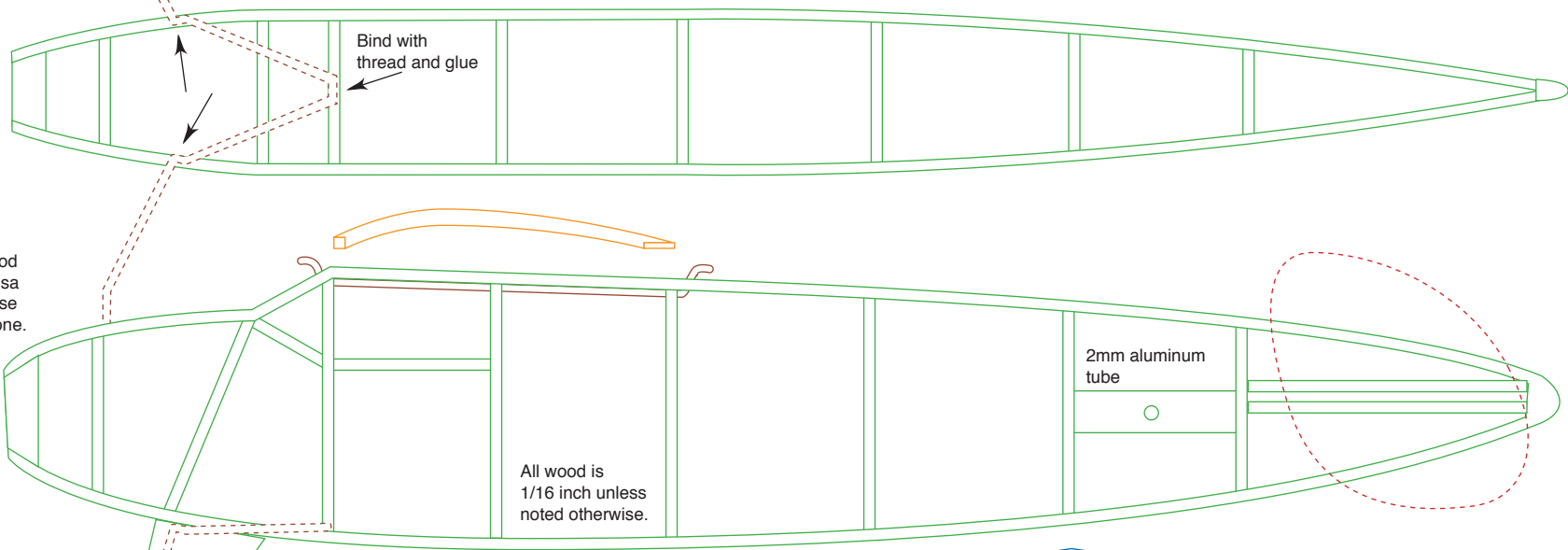

Wheels are 1/16 hard balsa with 2mm aluminum tube as hub. Wheel pants are built up using 1/32" sheet sides and sandwiched over 1/8 soft balsa for filling in around the wheel.

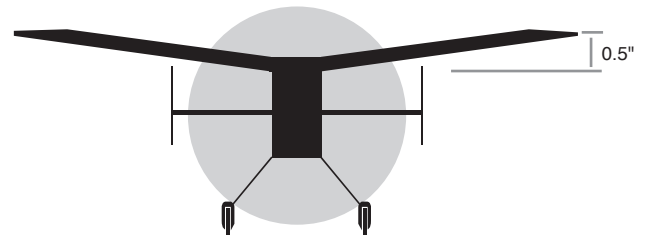
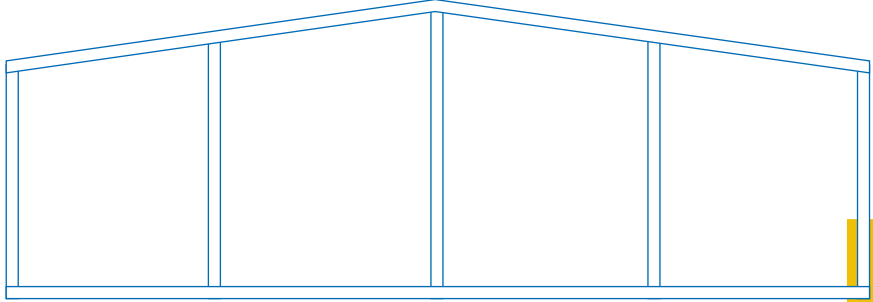
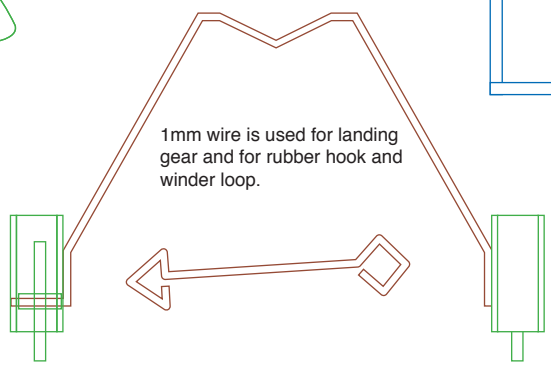
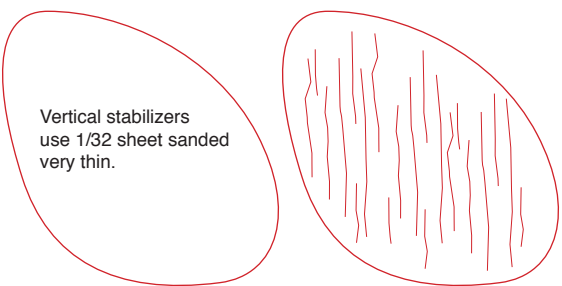
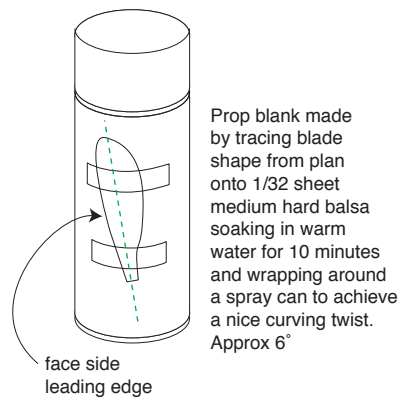
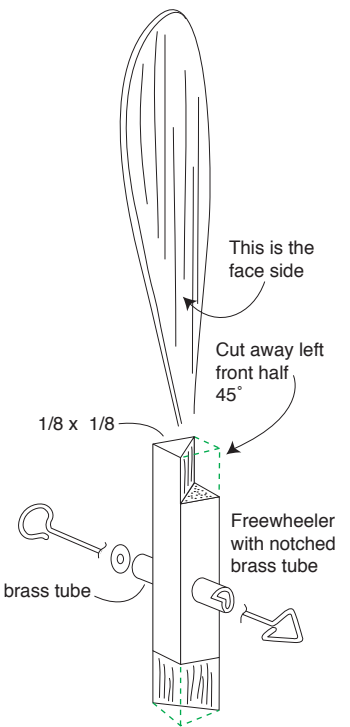

SISKIYOU LINER

Sport Flyer

Wingspan: 10.25"
Length: 8.875"

By Kenny Kaiser
www.xoomee.com