

24" 'ALTAIR' FORMERS
1/20" SHT.

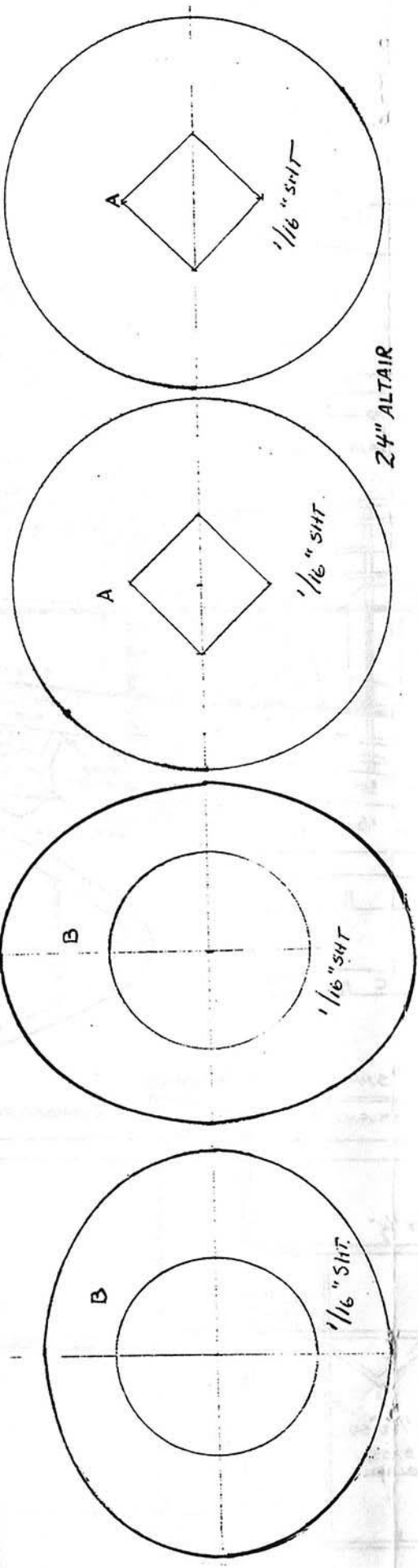

24" ALTAIR

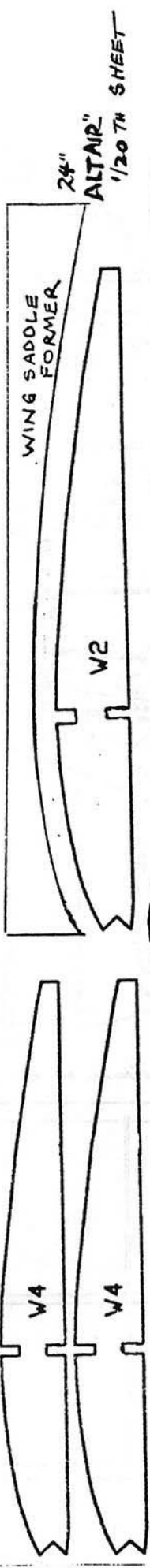
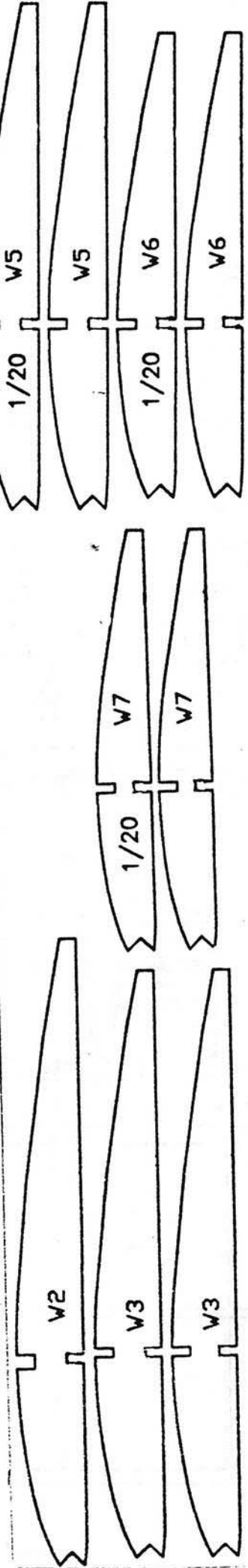
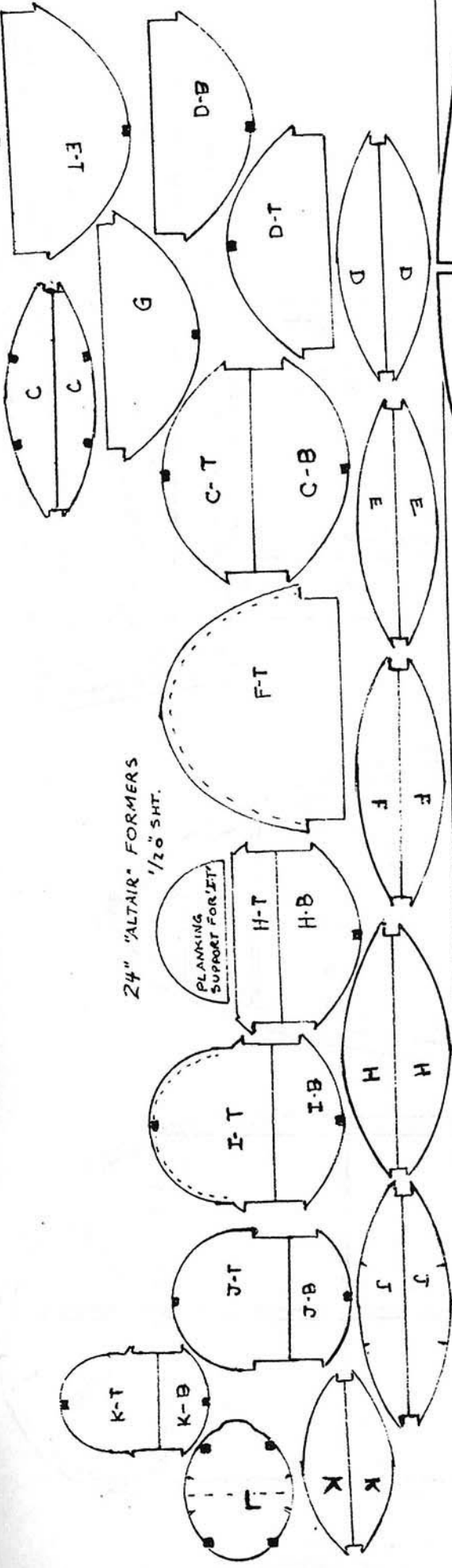
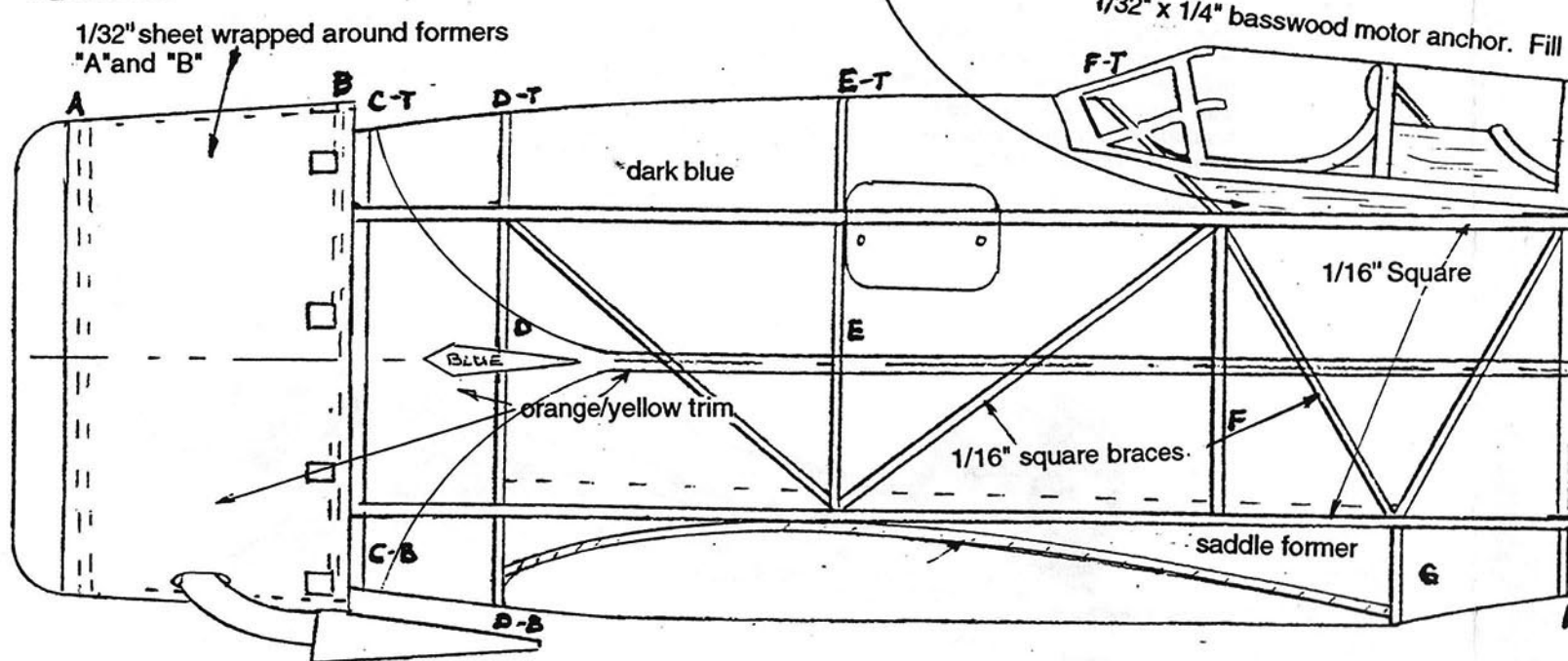
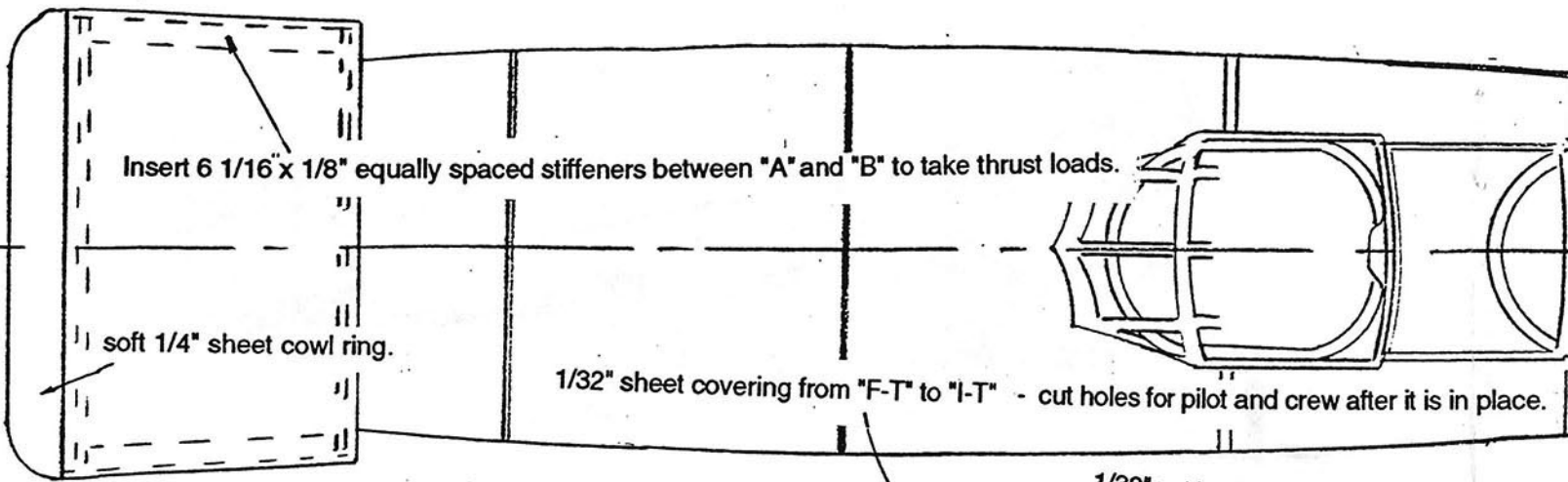

Use paper or contour fitted foam for wing root fairings (see text)

1/32" sheet saddle
4-7/8" long x 2' wide
sanded to fuselage
contour .

Make "A" from two layers of hard 1/16" sheet or
one layer of 1/16" plywood
"B" is two layers of hard 1/16" balsa

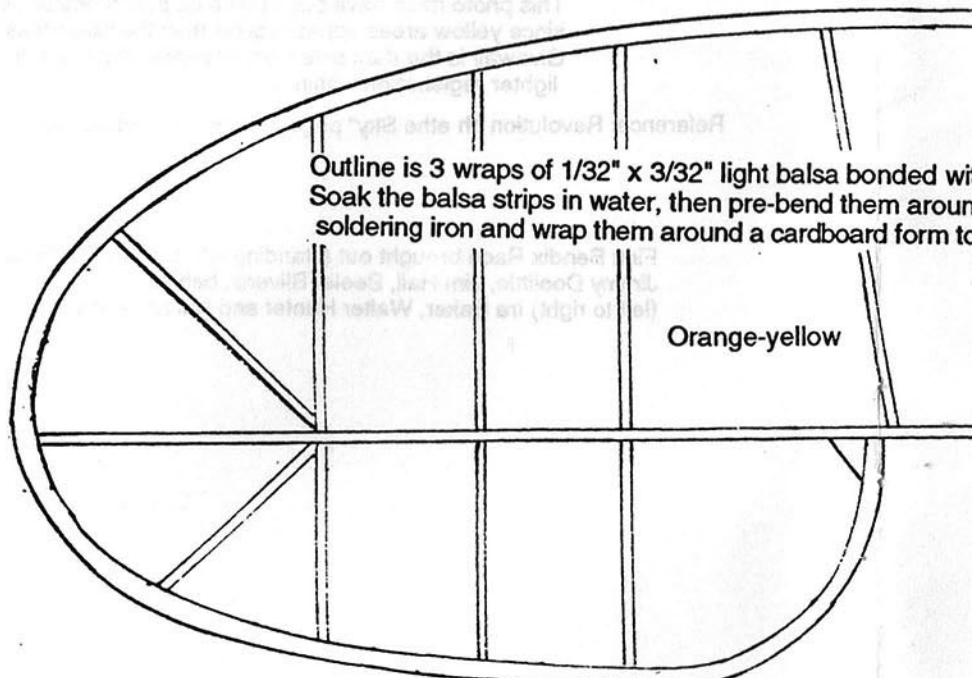

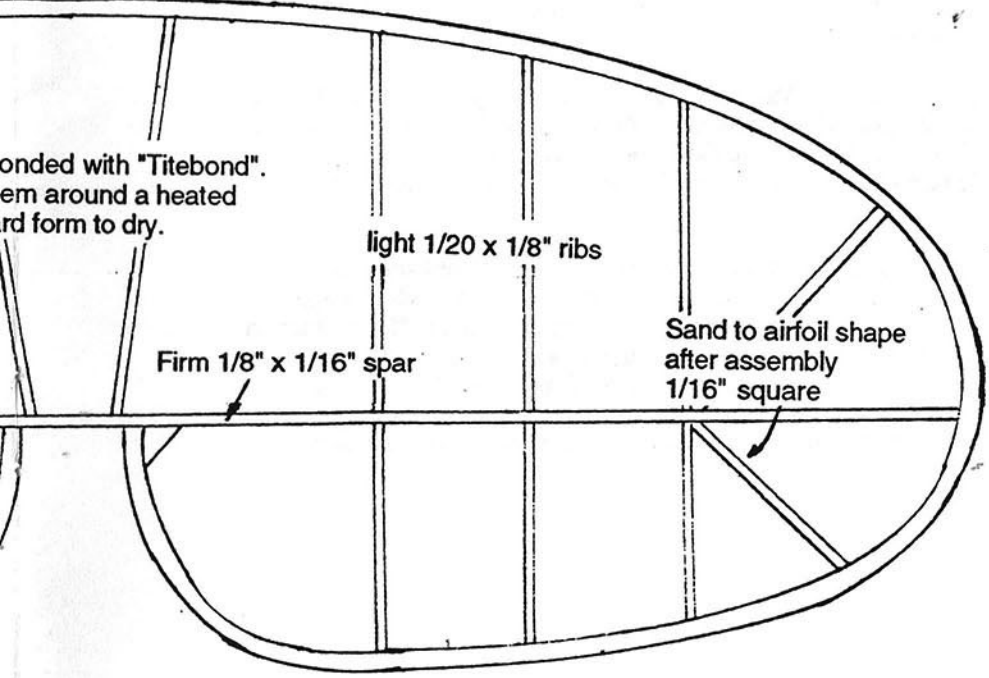
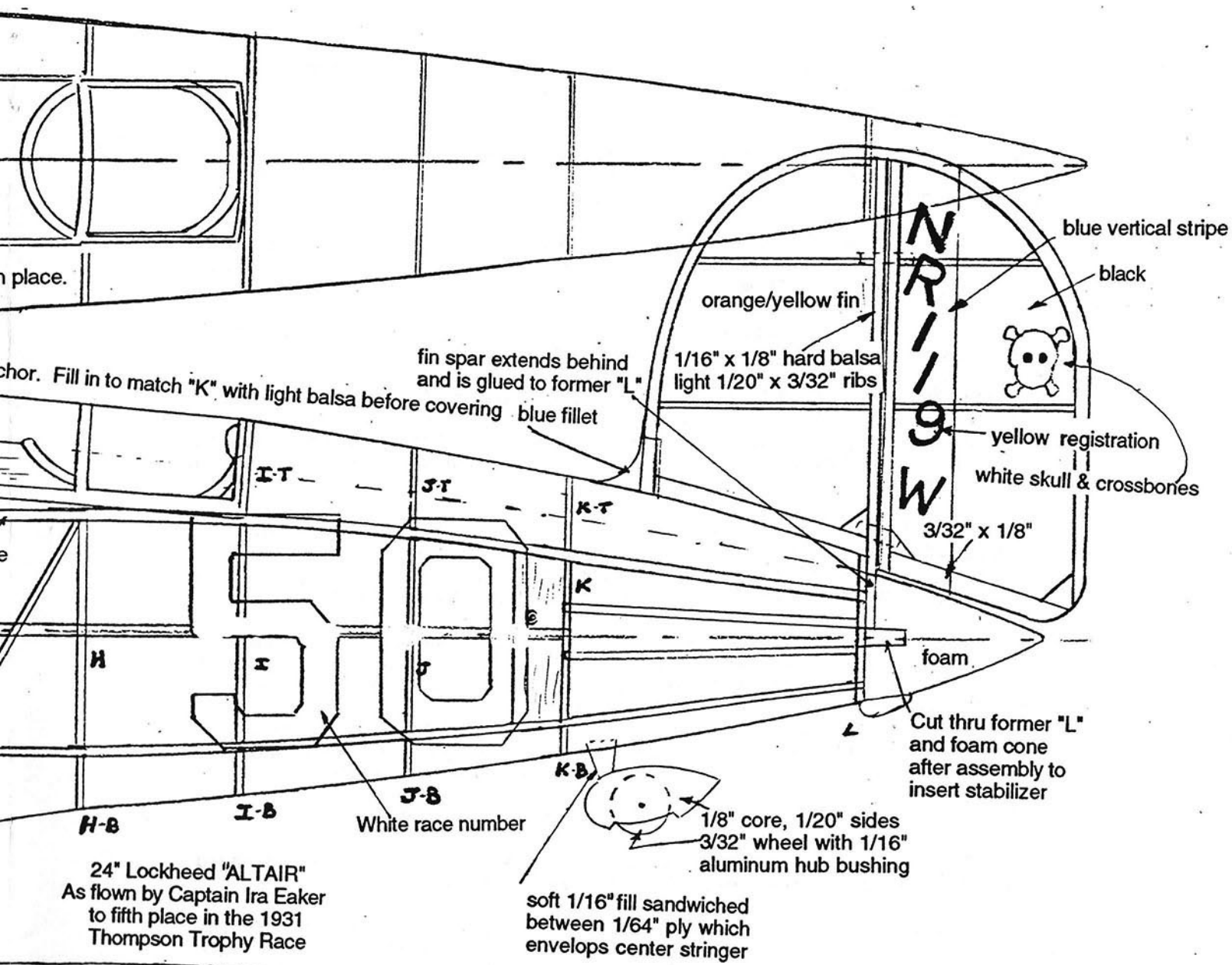

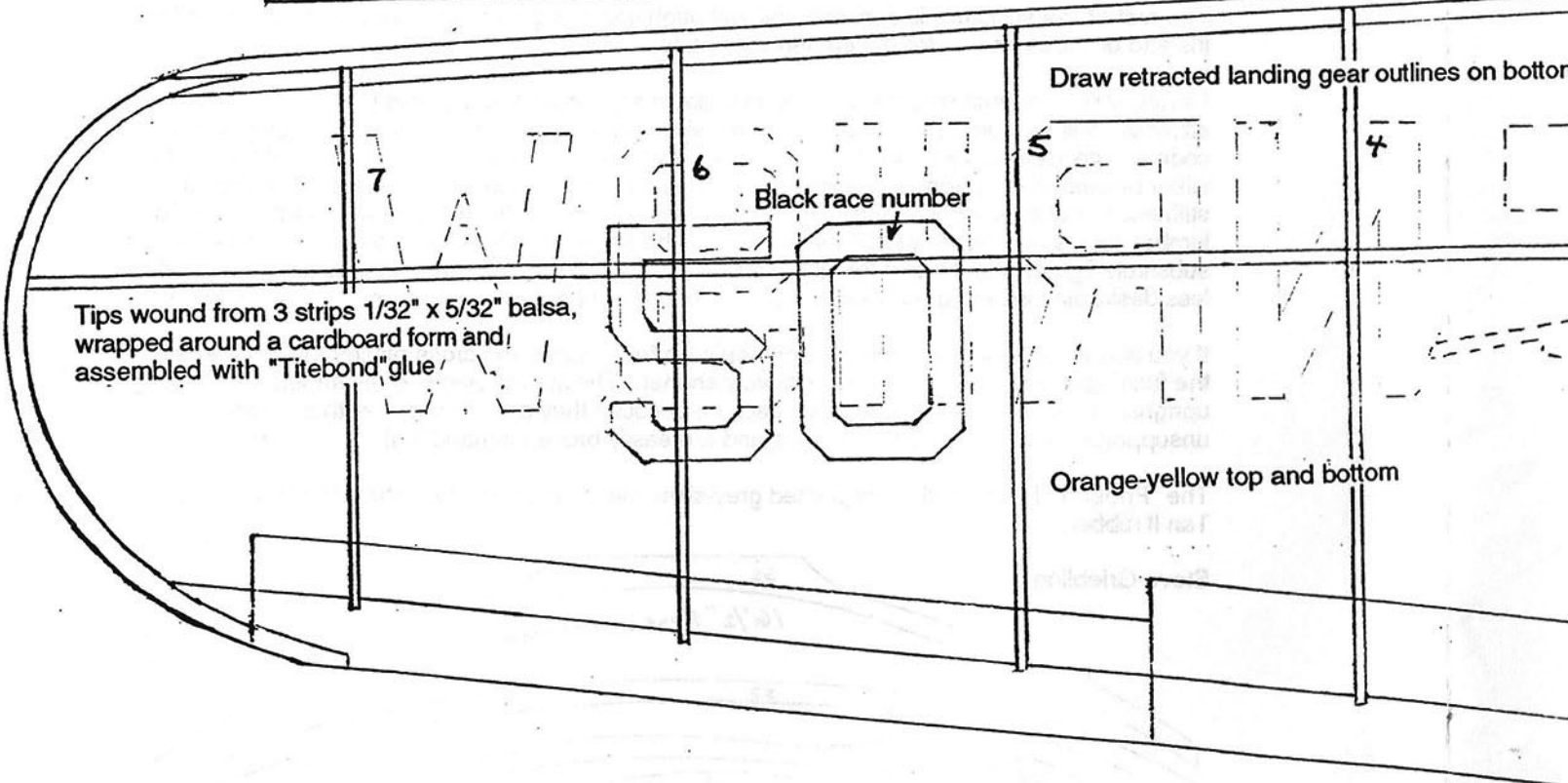
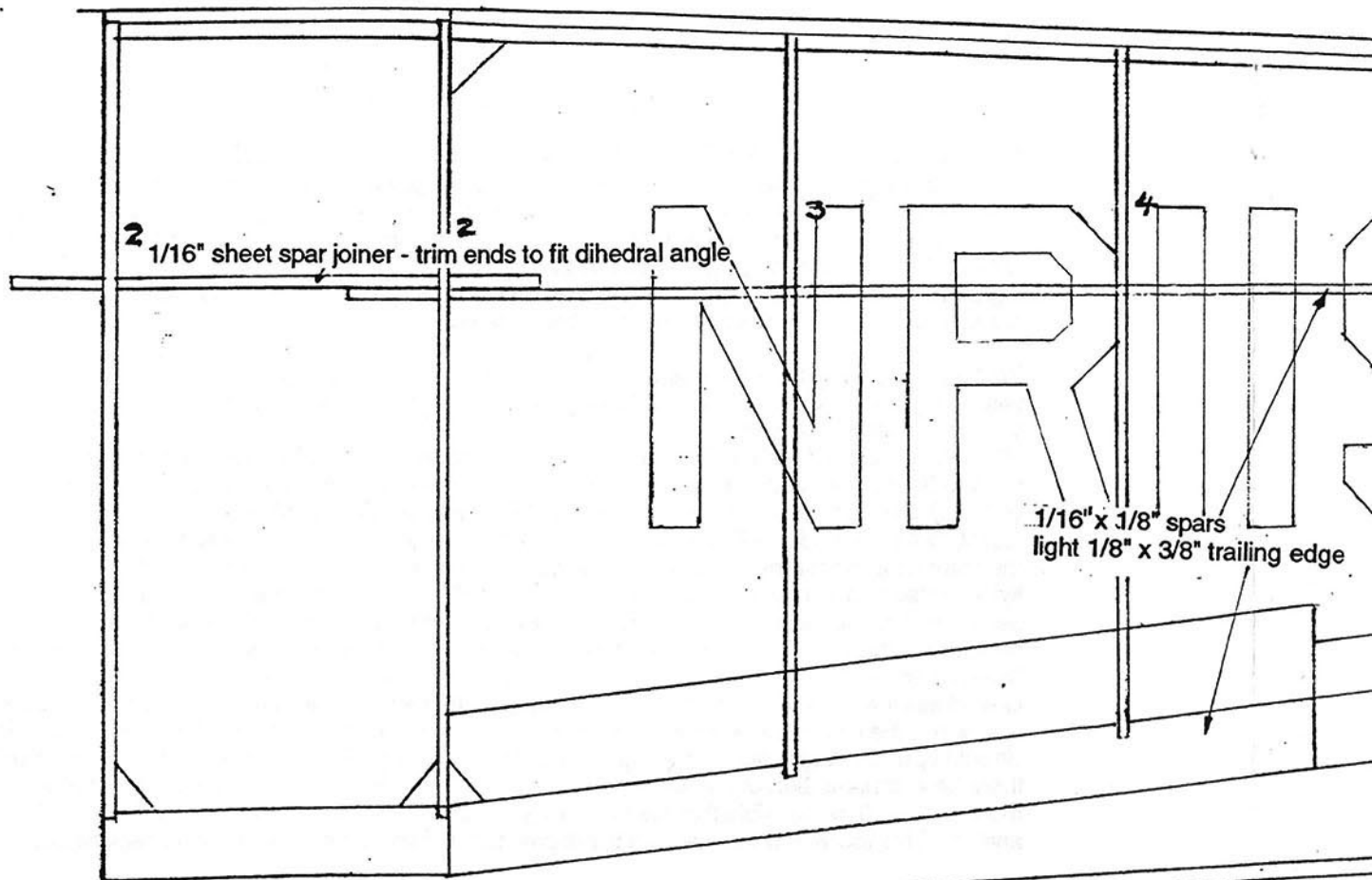

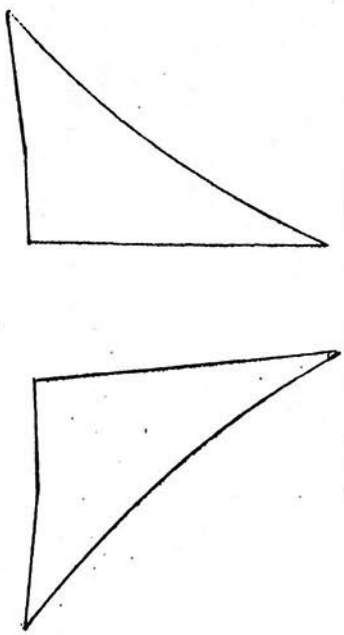
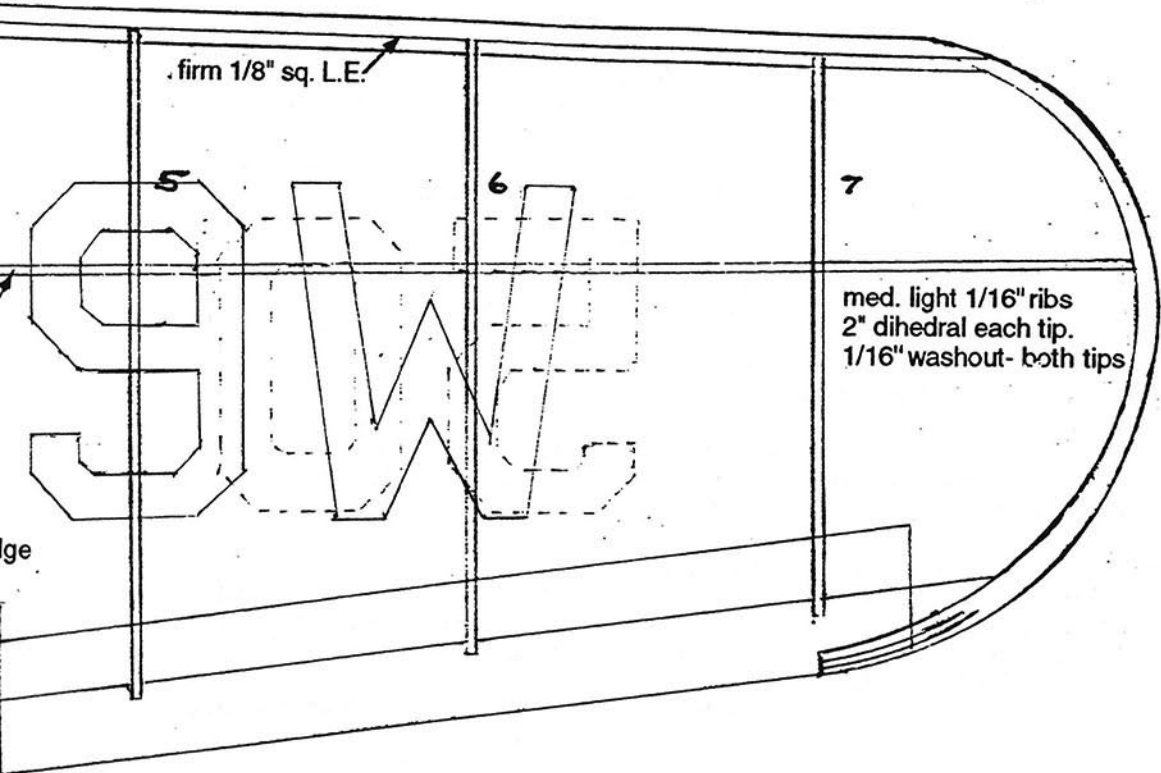

1/16" sheet trailing edge fillets.
assemble to plane after covering,
then cover them with yellow-orange tissue

