

GRUMMAN FIGHTER FF - 1

Make Pilot's and Observer's glass enclosure as follows: Use a good grade of heavy bond paper for the frames and cement cellophane to inside, bend frames to shape and cement in place.

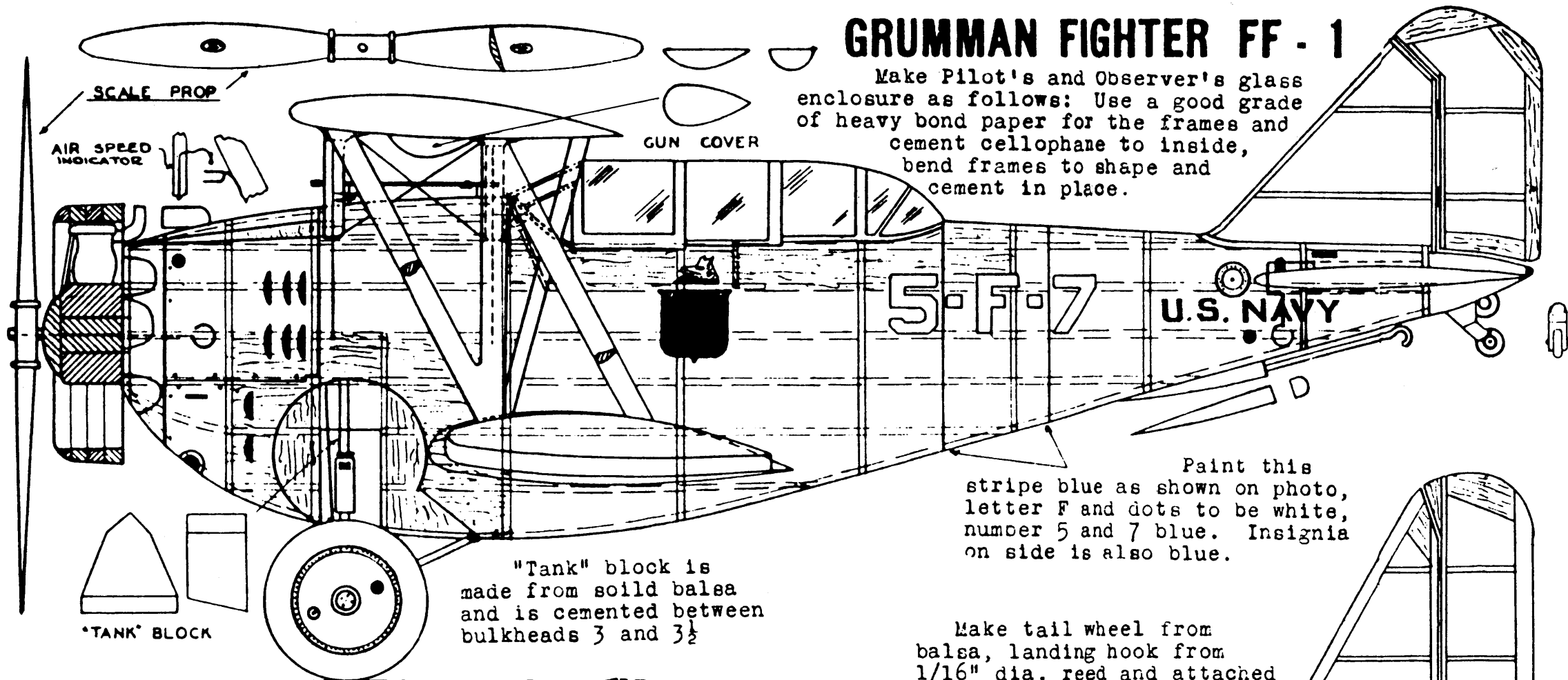

Paint this stripe blue as shown on photo, letter F and dots to be white, number 5 and 7 blue. Insignia on side is also blue.

"Tank" block is made from solid balsa and is cemented between bulkheads 3 and 3½

Make tail wheel from balsa, landing hook from 1/16" dia. reed and attached as shown.

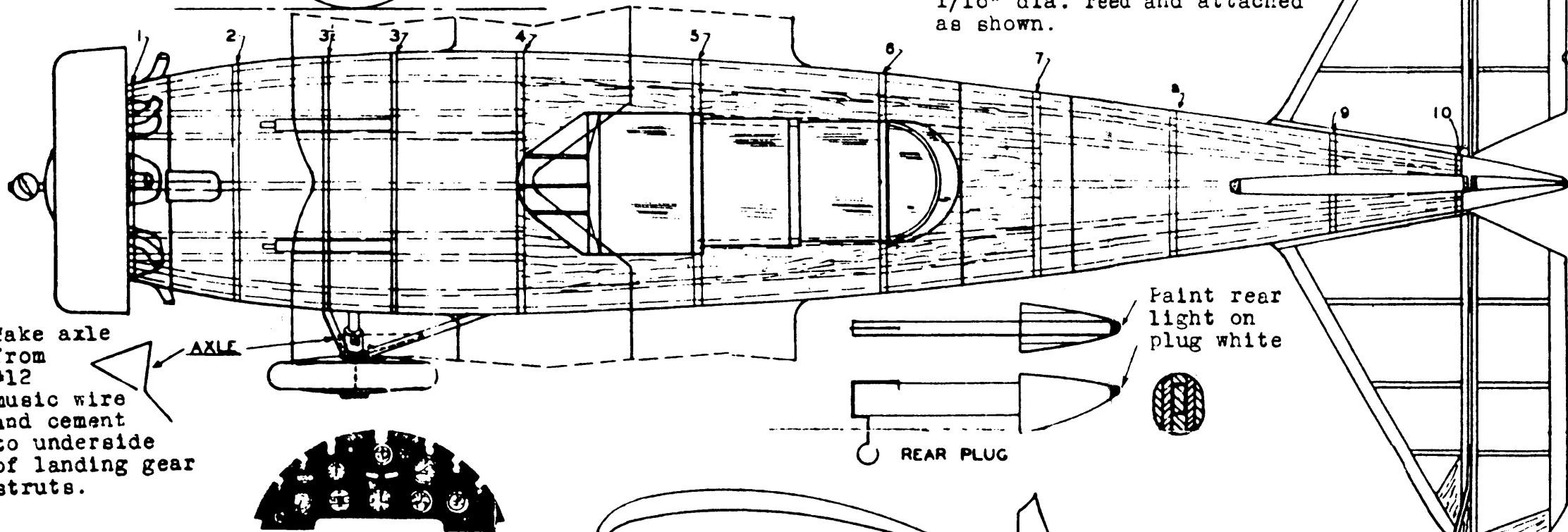
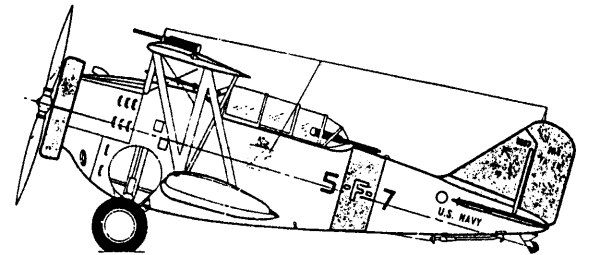

Make axle from #12 music wire and cement to underside of landing gear struts.

Paint rear light on plug white

PILOTS



OBSERVERS

NOTE: - DO NOT MAKE WING STUB THIS SHAPE

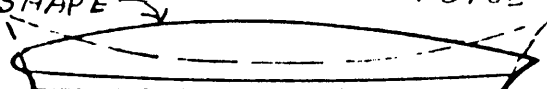

WING STUB

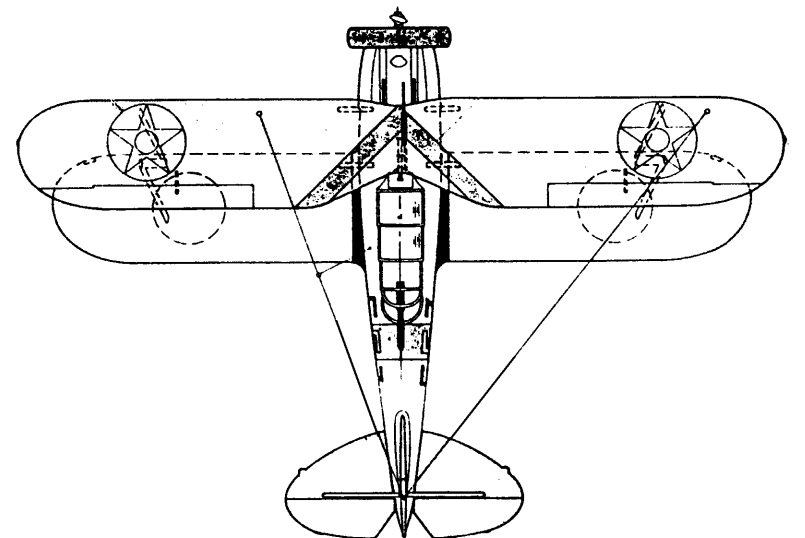
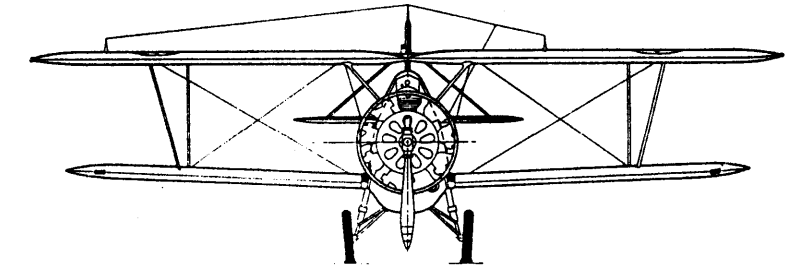

G-E MODEL SUPPLY COMPANY
1311 WADE STREET
CHICAGO, ILL.

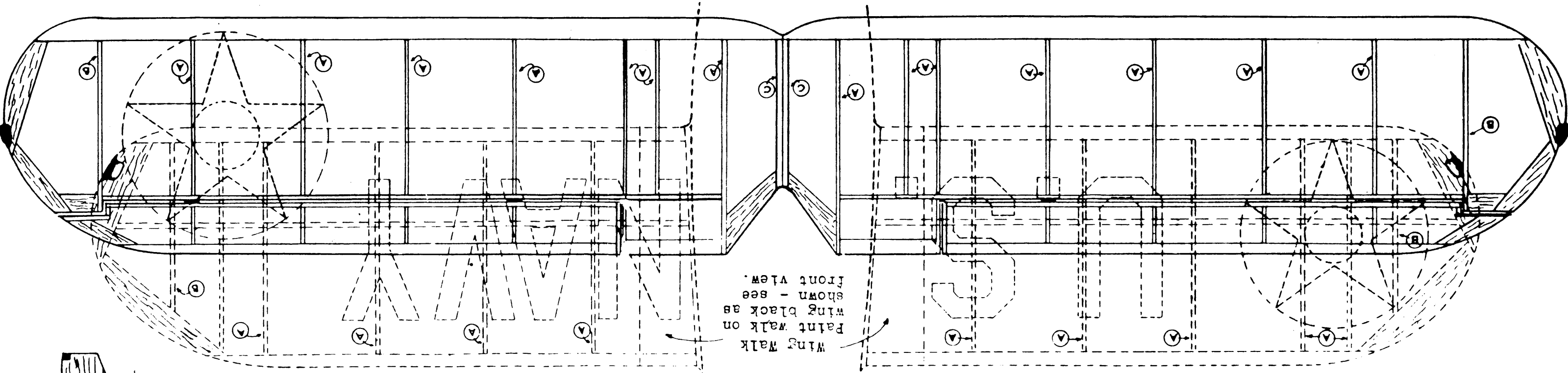

Wing walk on wing block as shown - see front view.

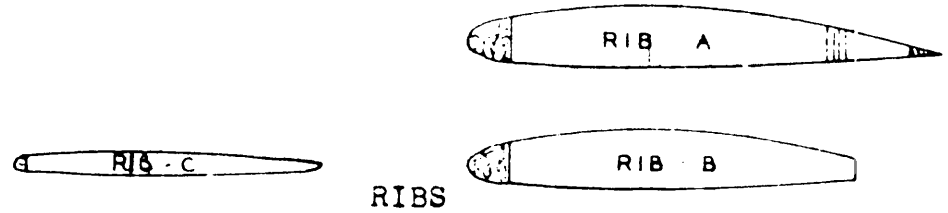
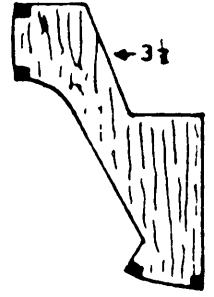

Make strut fillets, finishing with fine sandpaper, all exposed wood parts should be given two coats of clear dope.

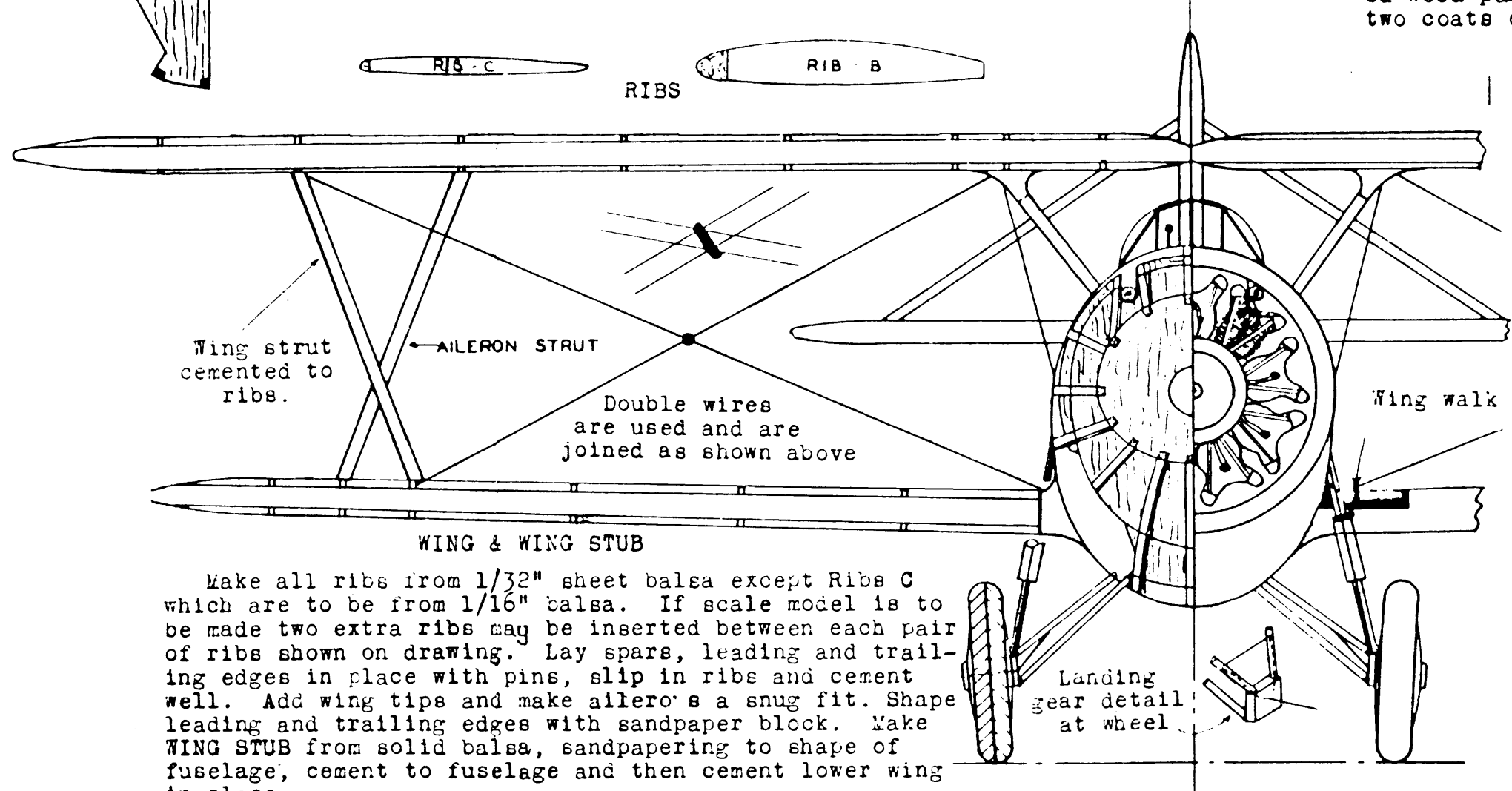
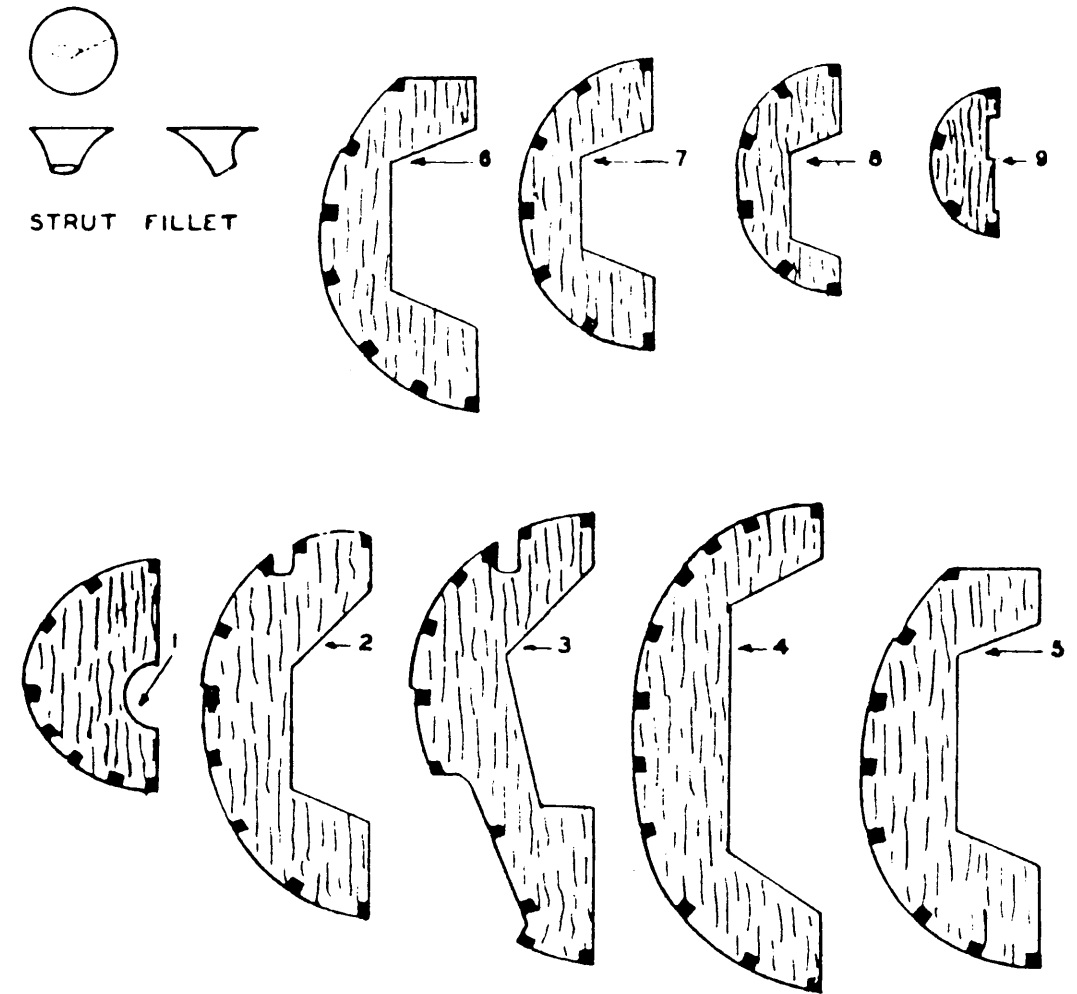

Make all ribs from 1/32" sheet balsa except Ribs C which are to be from 1/16" balsa. If scale model is to be made two extra ribs may be inserted between each pair of ribs shown on drawing. Lay spars, leading and trailing edges in place with pins, slip in ribs and cement well. Add wing tips and make ailerons a snug fit. Shape leading and trailing edges with sandpaper block. Make WING STUB from solid balsa, sandpapering to shape of fuselage, cement to fuselage and then cement lower wing in place.