

THIS PLAN NOT TO

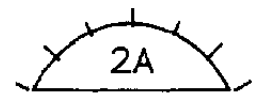

DOWN AND RIGHT
TRUST

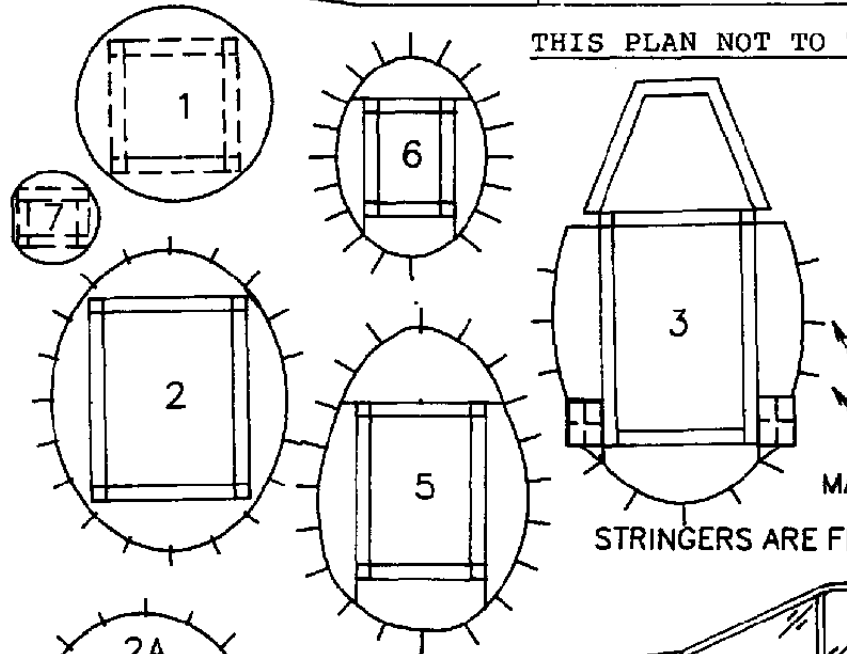
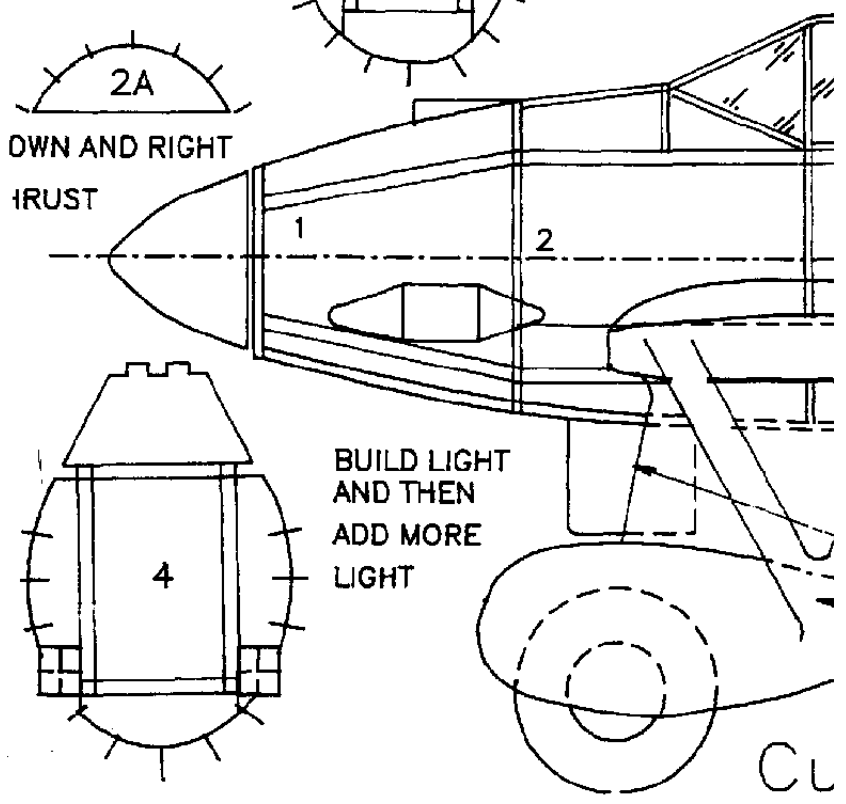

BUILD LIGHT
AND THEN
ADD MORE
LIGHT

CL

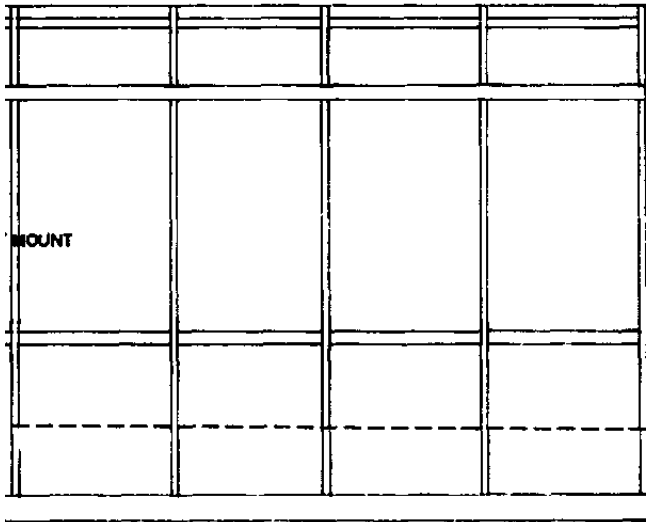

MOUNT

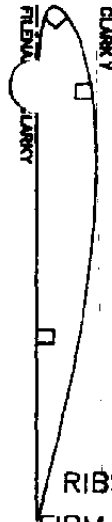

RIBS

FIRM 1/32

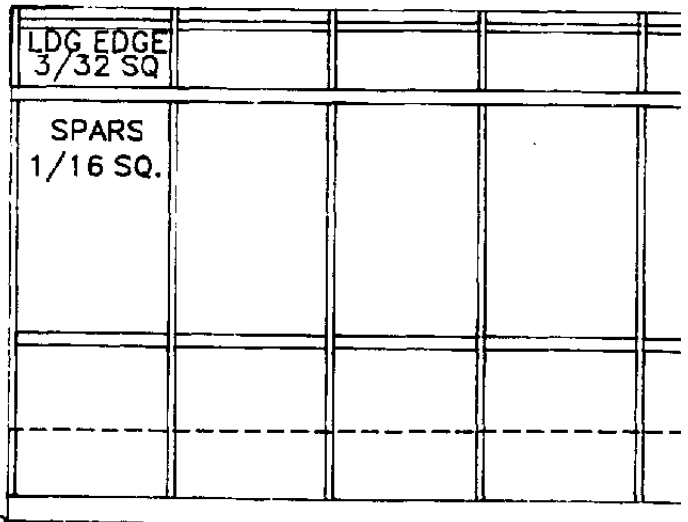

LDG EDGE
3/32 SQ

SPARS
1/16 SQ.

TO BE COPIED FOR RESALE

DRAWN BY DOUG WILKEY FOR FLYING ACES NEWSLETTER

TLG EDGE 1/

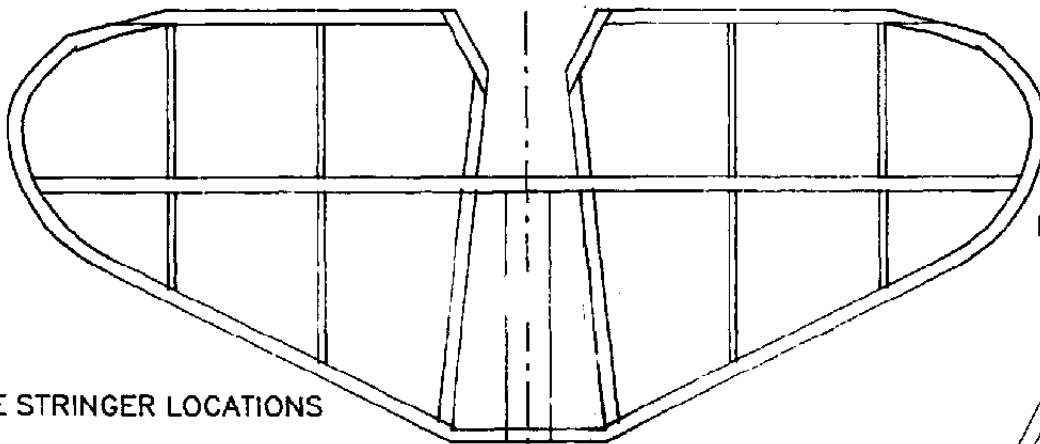

MARKS ARE STRINGER LOCATIONS

RE FLUSH WITH EDGE OF FORMER

BLUE

RED
W
R
W
R
W
R
W
R
W
R
W
R

7"PROP W/2 LOOPS 1/8"
MOTOR 150% OF PEG ROOM

USAAC
33-178

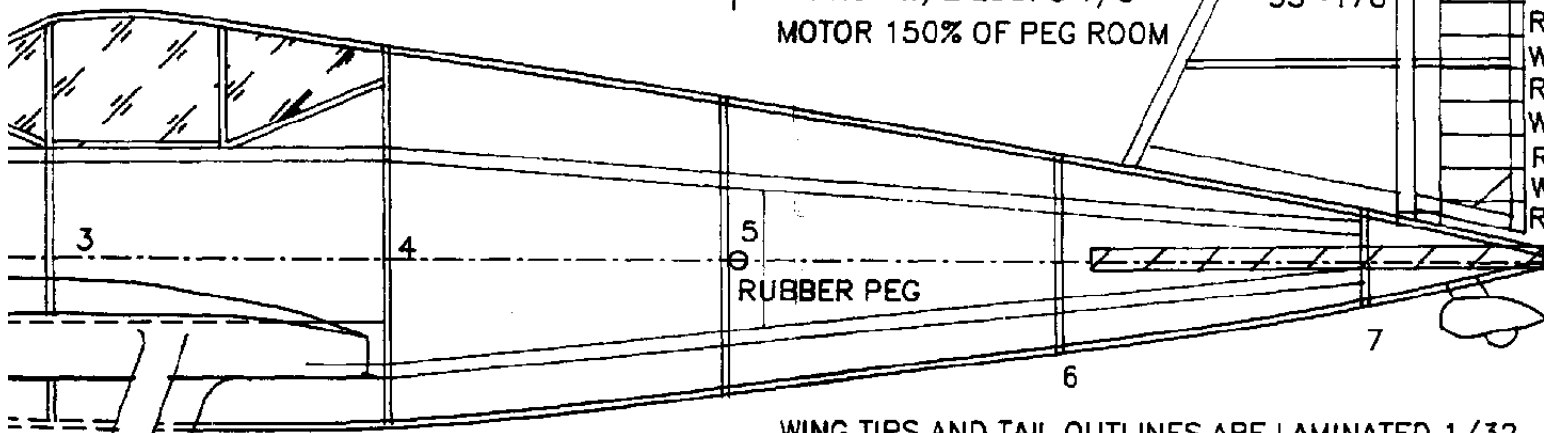

RUBBER PEG

6

7

WING TIPS AND TAIL OUTLINES ARE LAMINATED 1/32
BY 1/16.

STRINGERS ARE 1/32 BY 1/16
SOFT 1/4 SQ BETWEEN 2 AND 4 FOR WING MOUNT.

WINGS AND TAIL ARE YELLOW
FUSELAGE, LDG GEAR, STRUTS
WING ROOTS ARE OLIVE DRAB

MAIN LANDING GEAR OUTLINE 1/8 FIRM WOOD

WING STRUTS ARE 1/32 BY 3/8 PLY

01/25/95 SIXTY YEARS AFTER COMET MODELS.

A NEGLECTED LITTLE 30'S FIGHTER
DRAWN BY DOUG AND SANDY WILKEY

Curtiss XP-31 Swift

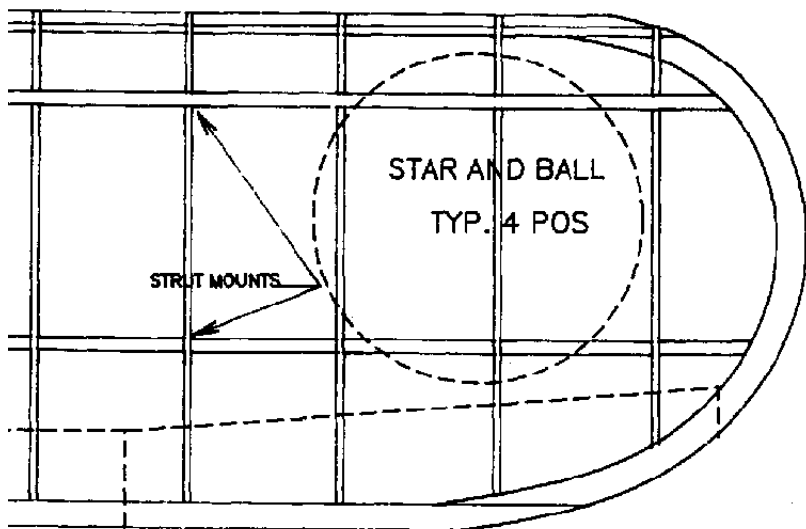

E 1/16 X 1/8

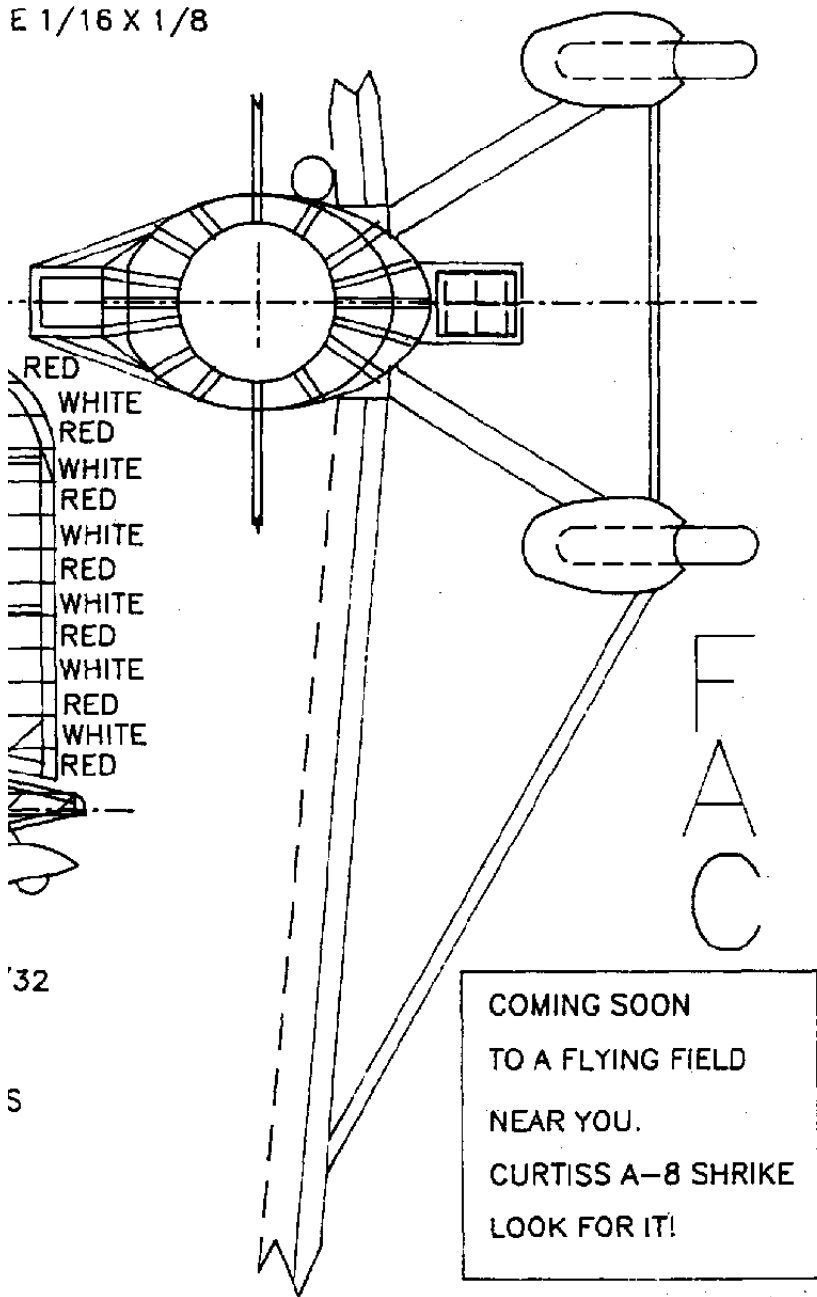

'32

S

COMING SOON
TO A FLYING FIELD
NEAR YOU.
CURTISS A-8 SHRIKE
LOOK FOR IT!