

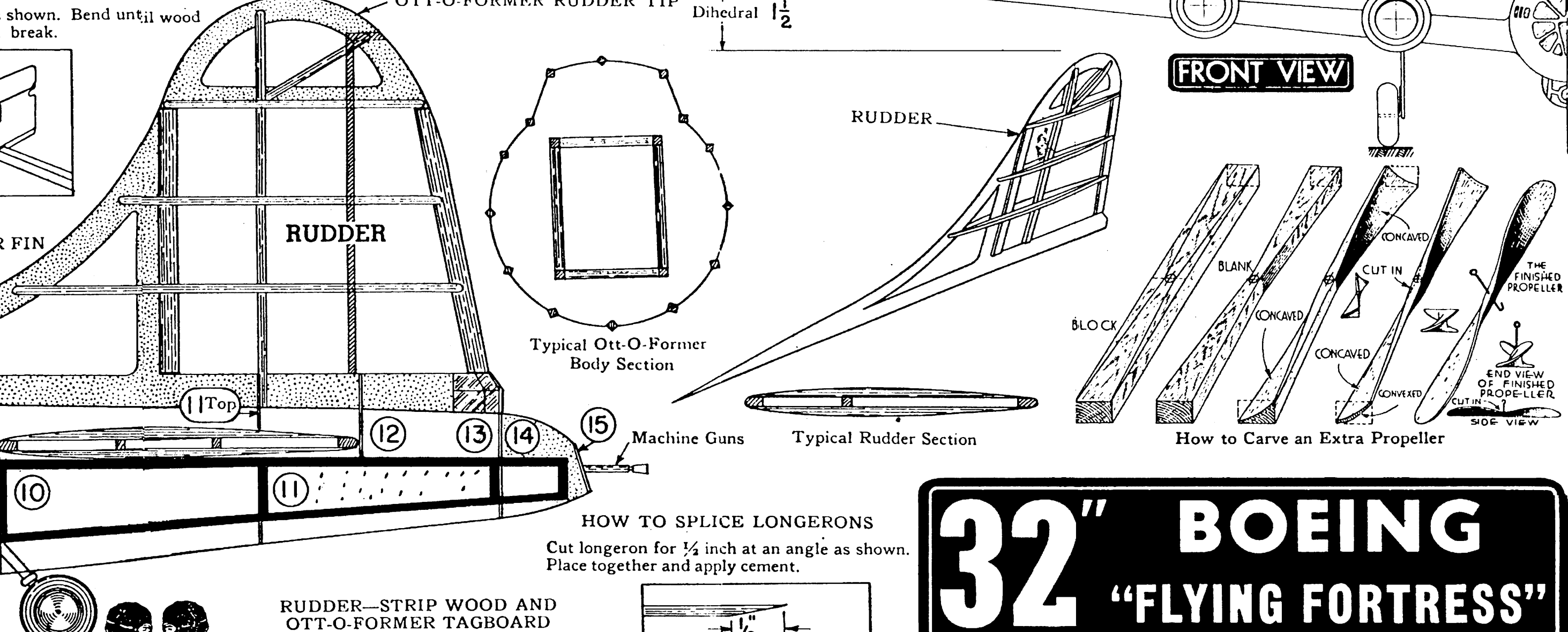

GENERAL INSTRUCTIONS BY JOE OTT
Study plans and sketches before starting any of the actual work. Pin plan to a soft board and use wax paper (not furnished) over plan to prevent the wood from sticking to the plan.

PILOT
Paper cutouts are furnished on the plan. Cement two opposites together and mount in cockpit.
WORK ON WING FROM THIS SIDE
Cut out black lines to use in outlining controls.

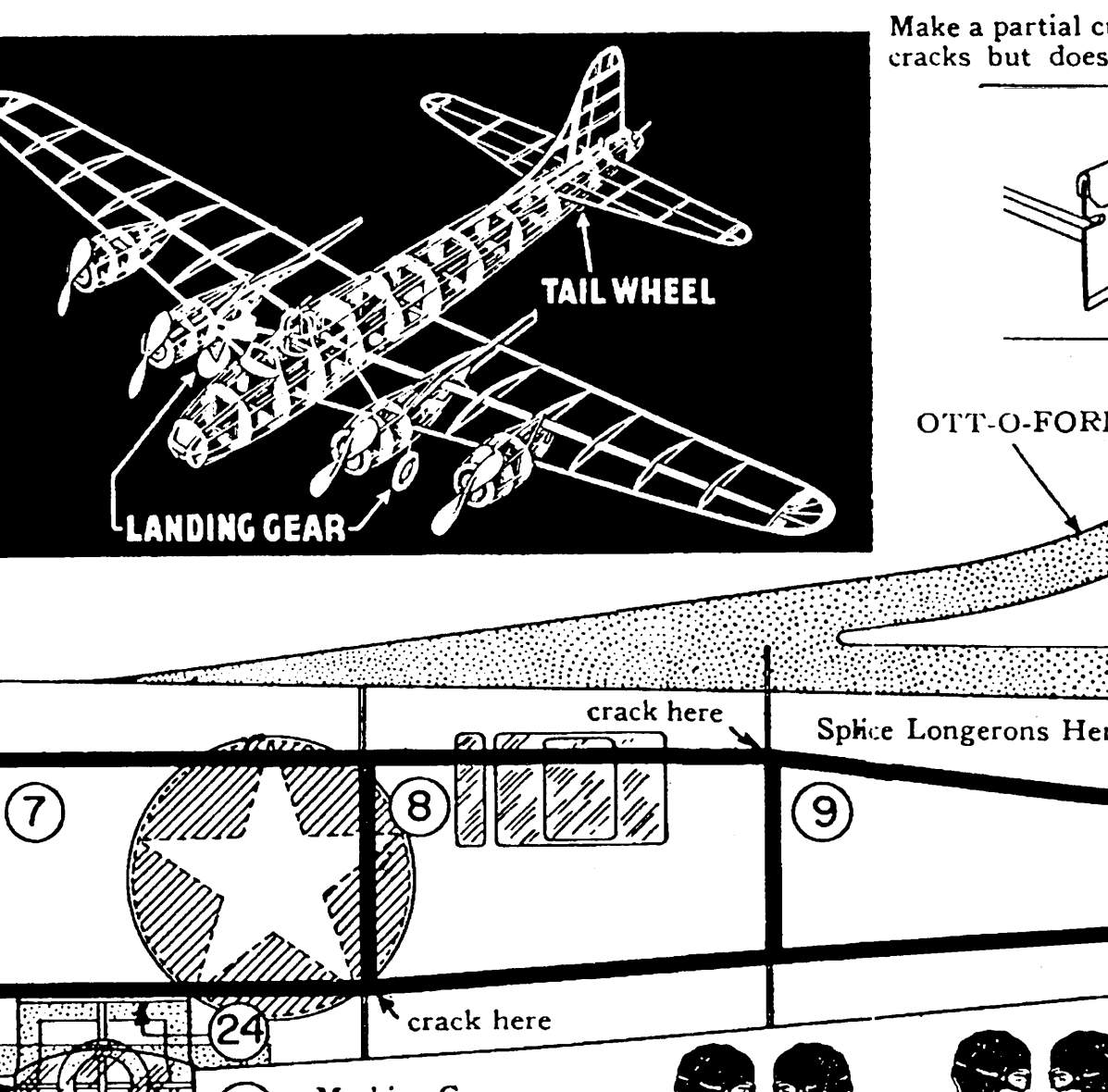
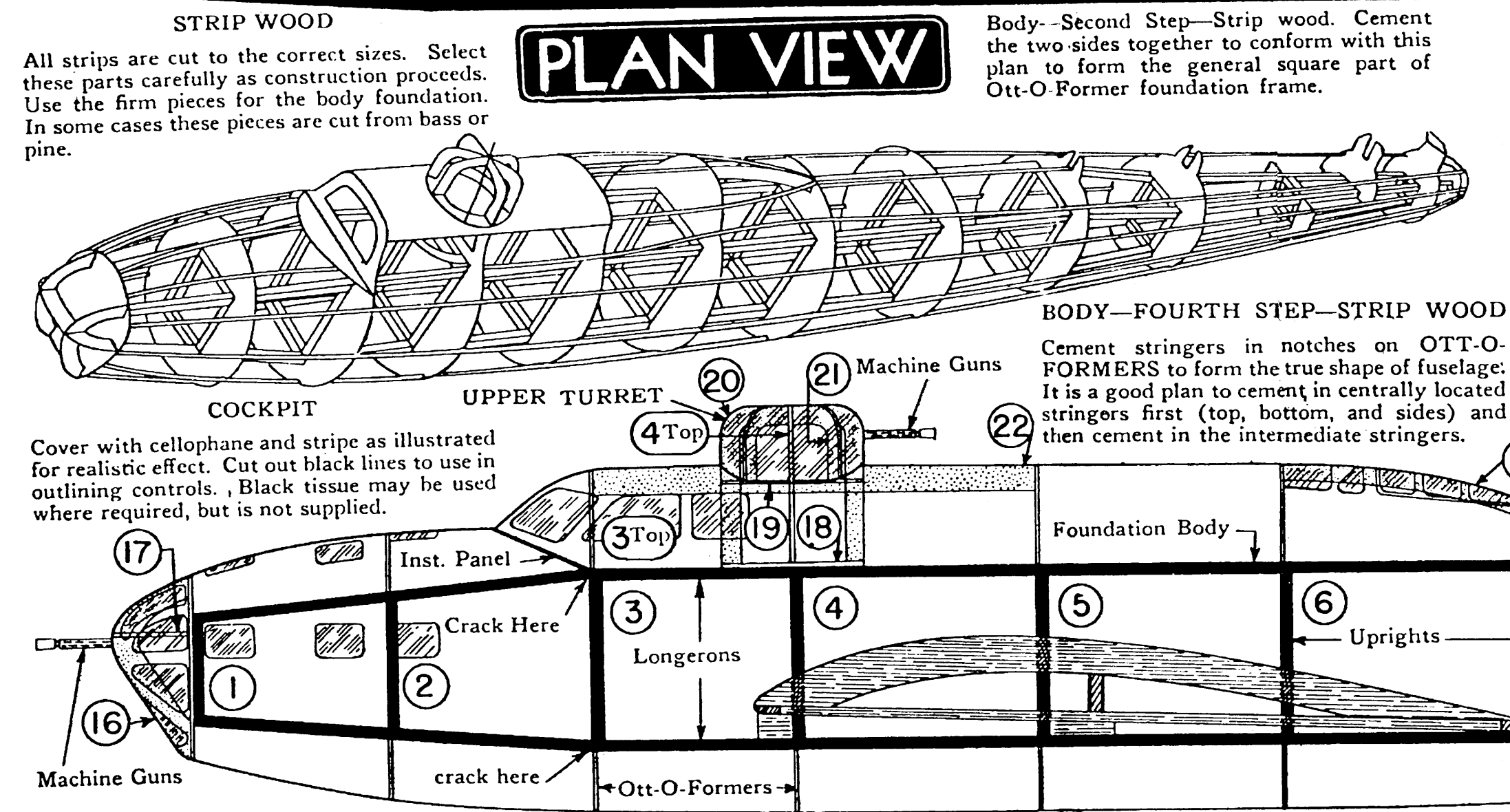
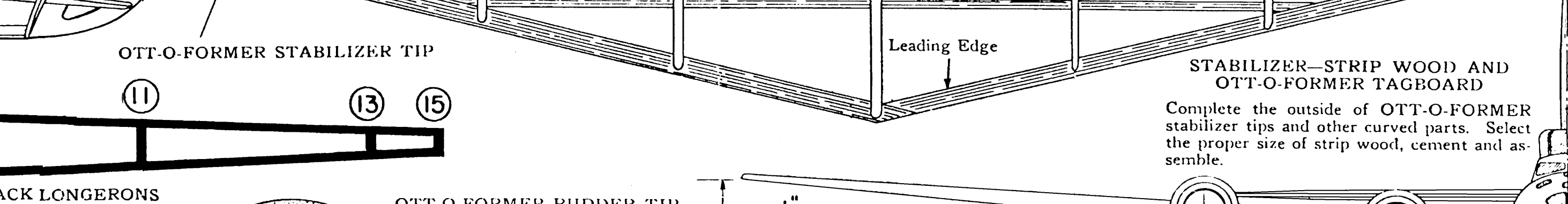
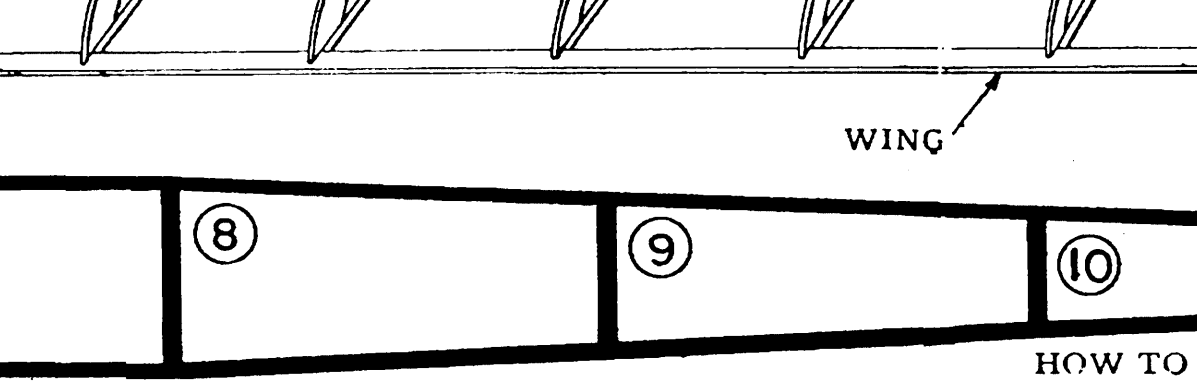
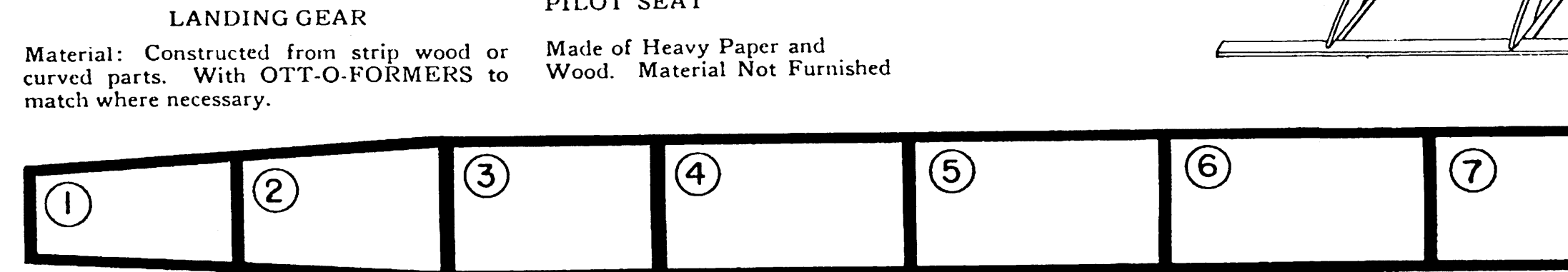
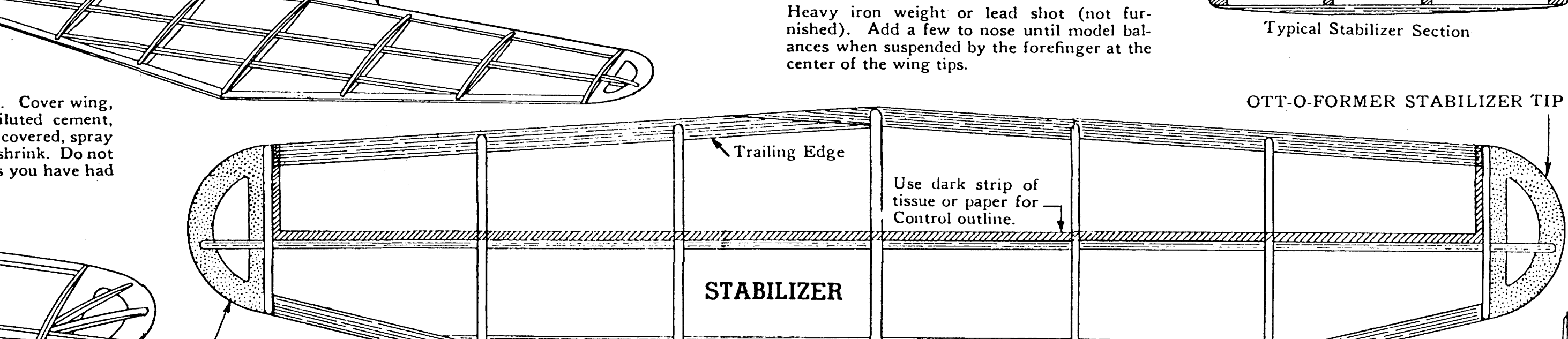
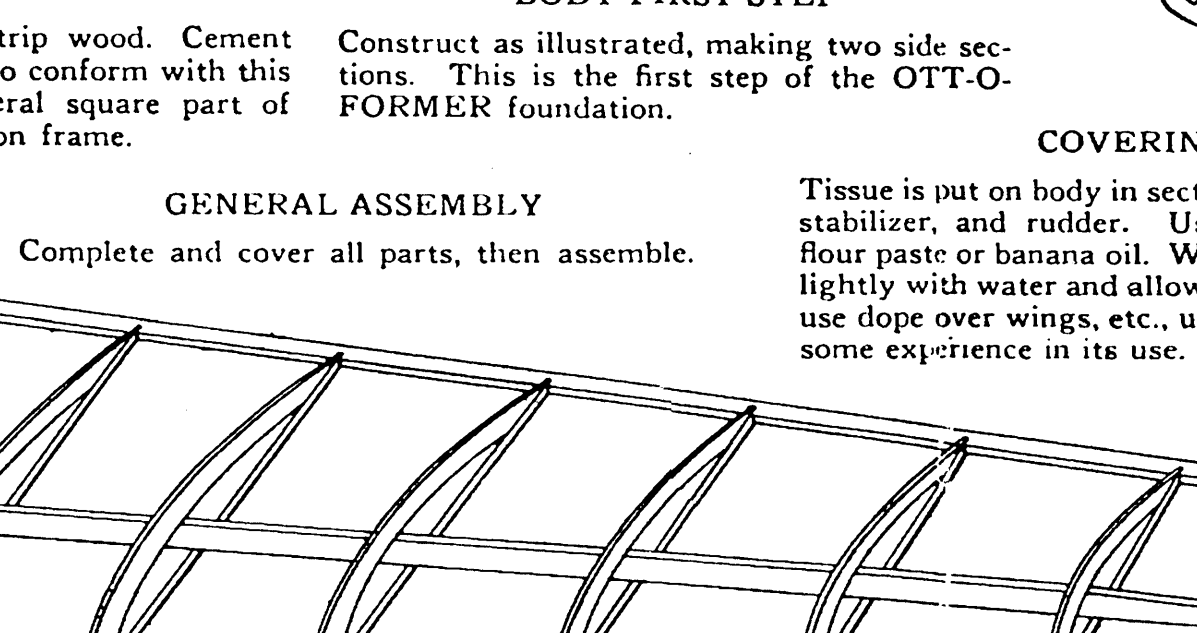
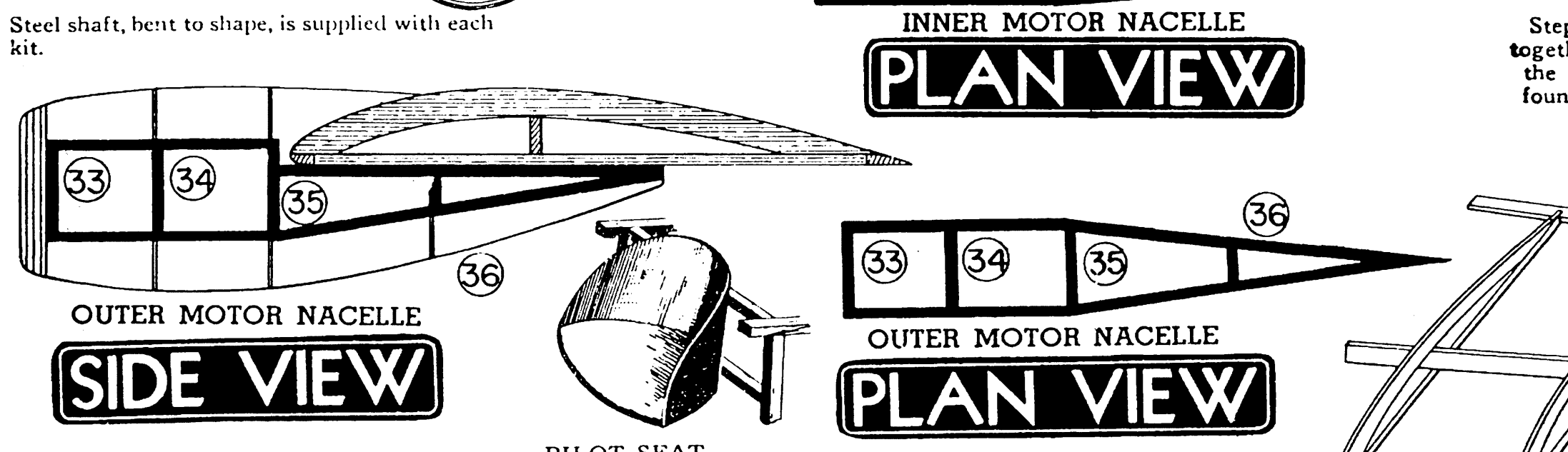
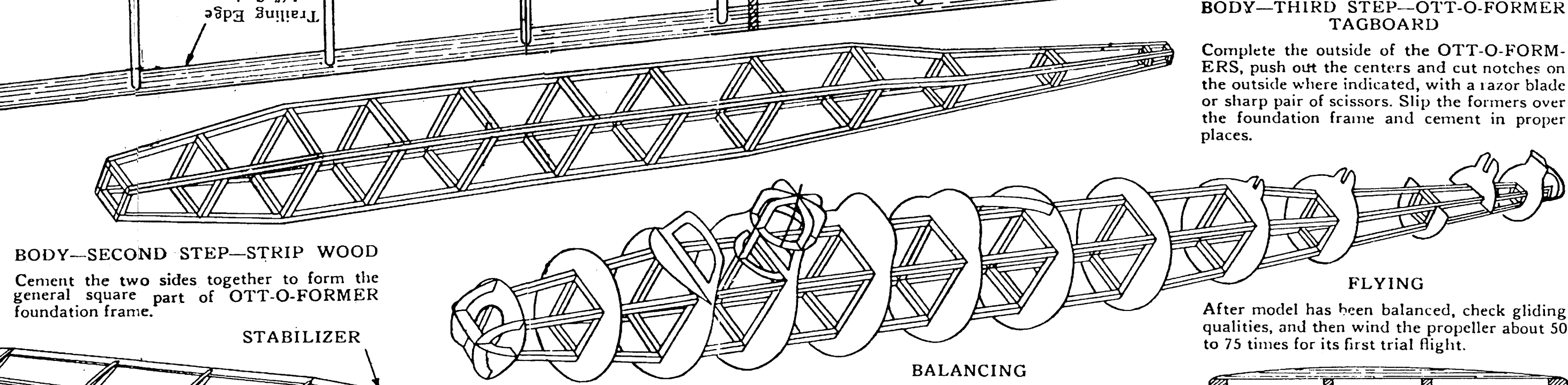
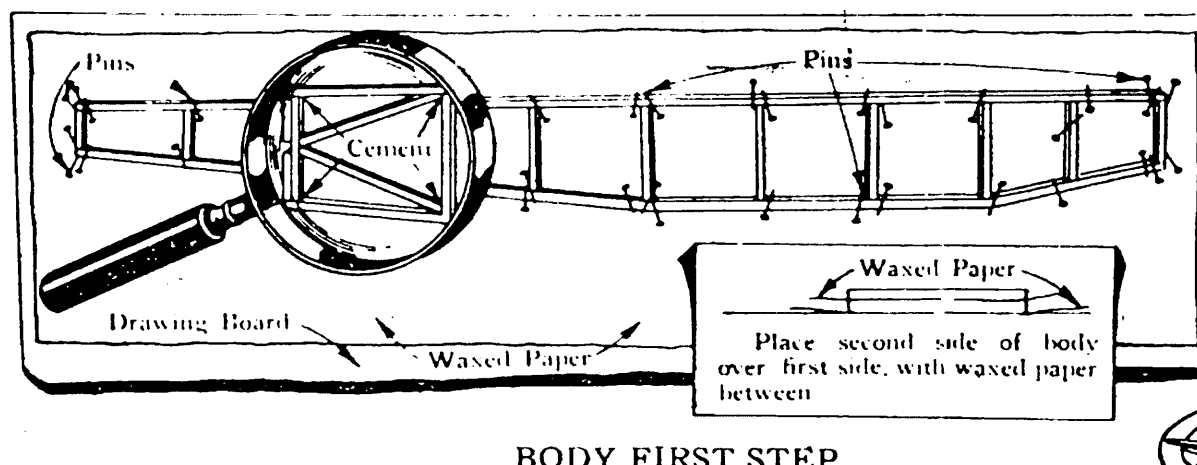
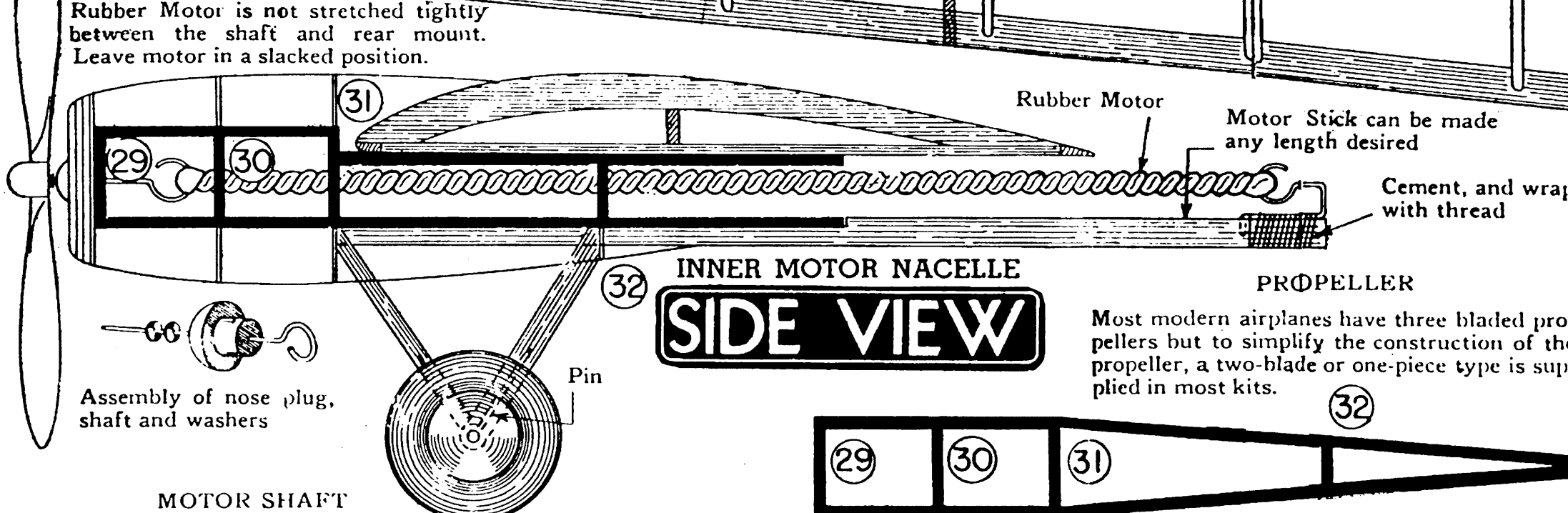
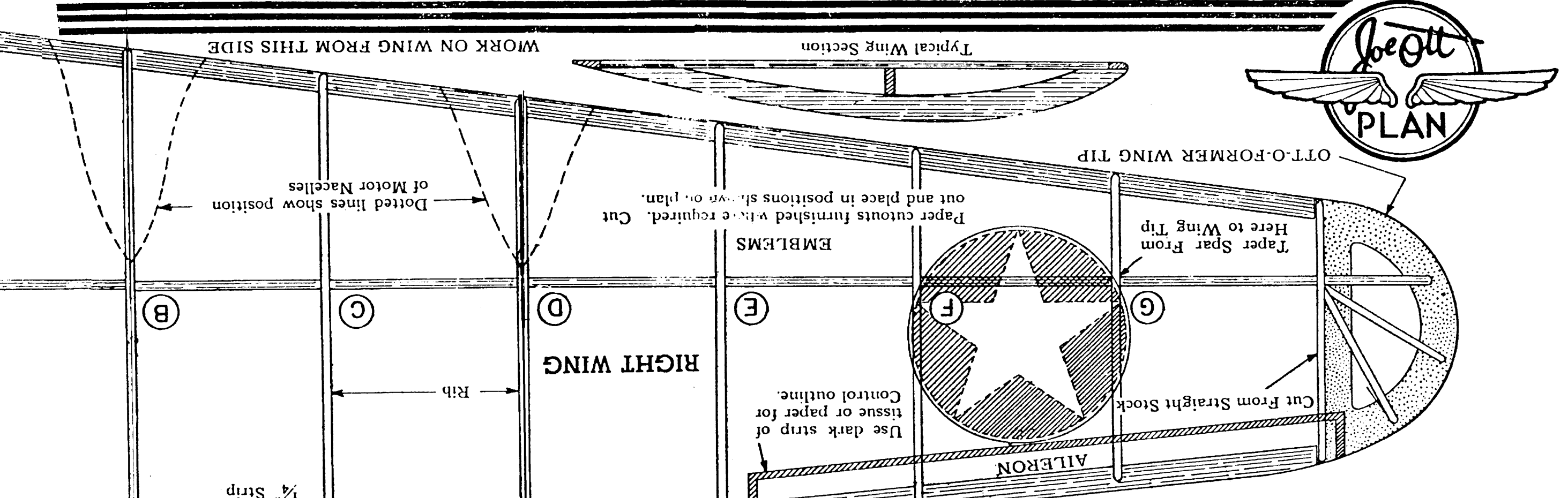
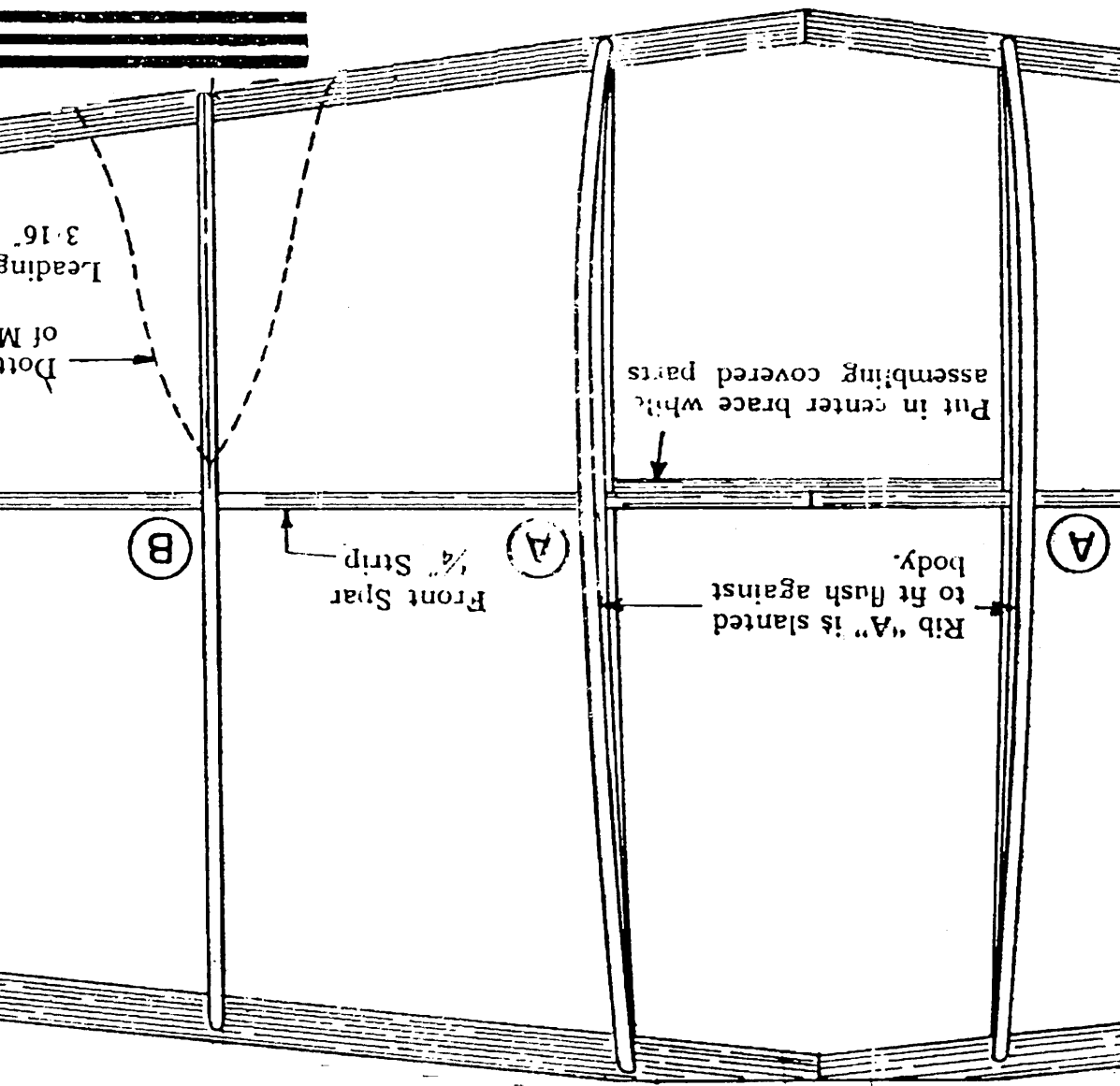
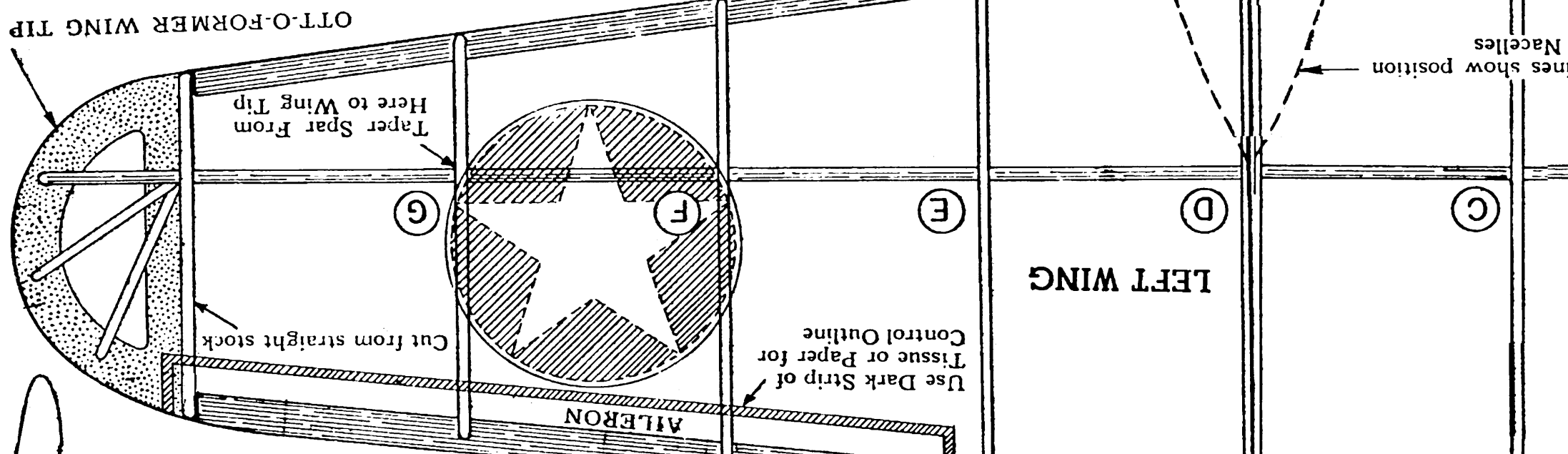

OTT-O-FORMERS
Copyrighted and Patented in U.S. Patent Office
JOE OTT MANUFACTURING CO. CHICAGO, ILL.
Printed in U.S.A.

SIDE VIEW

Use this full size plan and work with full size parts directly over drawing

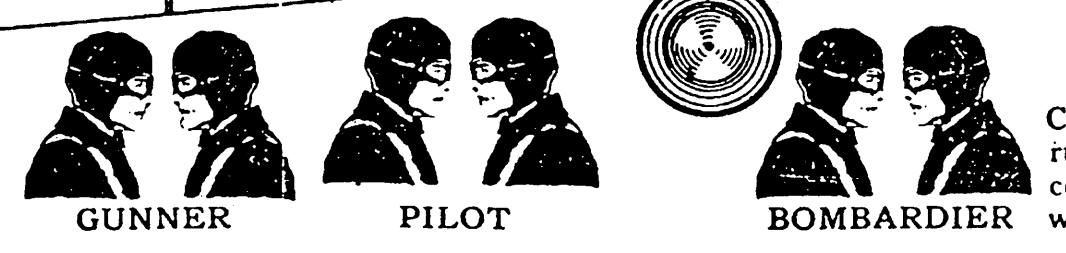

RUDDER—STRIP WOOD AND OTT-O-FORMER TAGBOARD
Complete the outside of OTT-O-FORMER rudder parts. Select proper size of strip wood, cement and assemble. Propeller, shaft and washers are supplied in each kit.

32" BOEING "FLYING FORTRESS"
OTTO-O-FORMER KIT FULL SIZE PLANS
ATTACK BOMBER FLYING MODEL No. 3219

32" Flying Fortress
Ott-O-Former No. 2

No 3
32" Flying Fortress
Ott-O-Former No. 3

No 4
32" Flying Fortress
Ott-O-Former No. 4

No 5
32" Flying Fortress
Ott-O-Former No. 5

No 6
32" Flying Fortress
Ott-O-Former No. 6

No 7
32" Flying Fortress
Ott-O-Former No. 7

No 10
32" Flying Fortress
No. 10

No 11
No. 11

No 13
No. 13

No 30
32" Flying Fortress
No. 30

No 31
32" Flying Fortress
No. 31

No 34
32" Flying Fortress
No. 34

No 9
32" Flying Fortress
Ott-O-Former No. 9

No 35
32" Flying Fortress
No. 35

No 36
No. 36

No 24
32" Flying Fortress
No. 24

32" Flying Fortress
Ott-O-Former No. 22

Bring Ends Together and Cement

Cement to Fuselage Around Lower Gun Turret

Cement to Fuselage Around Upper Gun Turret

No 32
No. 32

No 33
No. 33

No 30
No. 30

No 31
No. 31

No 34
No. 34

No 35
No. 35

No 36
No. 36

Ott-O-Formers Copyrighted This construction is covered and Patented

See light cardboard for additional Ott-O-Formers

No 3219-32" BOEING FLYING FORTRESS

TRACE CUT LINES WITH SHARP BLADE TO AVOID SPLITTING

BUILT UP NOSE BLOCK "FLYING FORTRESS"
No 3219-32" BOEING "FLYING FORTRESS"

A

B

C

D

E

F

G

H

I

J

K

L

M

N

O

P

Q

R

S

T

U

V

W

X

Y

Z

No 25
32" Flying Fortress
Ott-O-Former No. 25

No 26
32" Flying Fortress
Ott-O-Former No. 26

No 27
32" Flying Fortress
Ott-O-Former No. 27

No 18
32" Flying Fortress
Ott-O-Former No. 18

No 19
32" Flying Fortress
Ott-O-Former No. 19

No 20
32" Flying Fortress
Ott-O-Former No. 20

No 21
32" Flying Fortress
Ott-O-Former No. 21

No 22
32" Flying Fortress
Ott-O-Former No. 22

No 23
32" Flying Fortress
Ott-O-Former No. 23

No 24
32" Flying Fortress
Ott-O-Former No. 24

No 25
32" Flying Fortress
Ott-O-Former No. 25

No 26
32" Flying Fortress
Ott-O-Former No. 26

No 27
32" Flying Fortress
Ott-O-Former No. 27

No 28
32" Flying Fortress
Ott-O-Former No. 28

No 29
32" Flying Fortress
Ott-O-Former No. 29

No 30
32" Flying Fortress
Ott-O-Former No. 30

No 31
32" Flying Fortress
Ott-O-Former No. 31

No 32
32" Flying Fortress
Ott-O-Former No. 32

No 33
32" Flying Fortress
Ott-O-Former No. 33

No 34
32" Flying Fortress
Ott-O-Former No. 34

No 35
32" Flying Fortress
Ott-O-Former No. 35

No 36
32" Flying Fortress
Ott-O-Former No. 36

No 11
32" Flying Fortress
Ott-O-Former No. 11

No 12
32" Flying Fortress
Ott-O-Former No. 12

No 13
32" Flying Fortress
Ott-O-Former No. 13

No 14
32" Flying Fortress
Ott-O-Former No. 14

No 15
32" Flying Fortress
Ott-O-Former No. 15

No 16
32" Flying Fortress
Ott-O-Former No. 16

No 17
32" Flying Fortress
Ott-O-Former No. 17

No 18
32" Flying Fortress
Ott-O-Former No. 18

No 19
32" Flying Fortress
Ott-O-Former No. 19

No 20
32" Flying Fortress
Ott-O-Former No. 20

No 21
32" Flying Fortress
Ott-O-Former No. 21

No 22
32" Flying Fortress
Ott-O-Former No. 22

No 23
32" Flying Fortress
Ott-O-Former No. 23

No 24
32" Flying Fortress
Ott-O-Former No. 24

No 25
32" Flying Fortress
Ott-O-Former No. 25

No 26
32" Flying Fortress
Ott-O-Former No. 26

No 27
32" Flying Fortress
Ott-O-Former No. 27

No 28
32" Flying Fortress
Ott-O-Former No. 28

No 29
32" Flying Fortress
Ott-O-Former No. 29

No 30
32" Flying Fortress
Ott-O-Former No. 30

No 31
32" Flying Fortress
Ott-O-Former No. 31

No 32
32" Flying Fortress
Ott-O-Former No. 32

No 33
32" Flying Fortress
Ott-O-Former No. 33

No 34
32" Flying Fortress
Ott-O-Former No. 34

No 35
32" Flying Fortress
Ott-O-Former No. 35

No 36
32" Flying Fortress
Ott-O-Former No. 36

No 37
32" Flying Fortress
Ott-O-Former No. 37

No 38
32" Flying Fortress
Ott-O-Former No. 38

No 39
32" Flying Fortress
Ott-O-Former No. 39

No 40
32" Flying Fortress
Ott-O-Former No. 40

No 41
32" Flying Fortress
Ott-O-Former No. 41

No 42
32" Flying Fortress
Ott-O-Former No. 42

No 43
32" Flying Fortress
Ott-O-Former No. 43

No 44
32" Flying Fortress
Ott-O-Former No. 44

No 45
32" Flying Fortress
Ott-O-Former No. 45

No 46
32" Flying Fortress
Ott-O-Former No. 46

No 47
32" Flying Fortress
Ott-O-Former No. 47

No 48
32" Flying Fortress
Ott-O-Former No. 48

No 49
32" Flying Fortress
Ott-O-Former No. 49

No 50
32" Flying Fortress
Ott-O-Former No. 50

No 51
32" Flying Fortress
Ott-O-Former No. 51

No 52
32" Flying Fortress
Ott-O-Former No. 52

No 53
32" Flying Fortress
Ott-O-Former No. 53

No 54
32" Flying Fortress
Ott-O-Former No. 54

No 55
32" Flying Fortress
Ott-O-Former No. 55

No 56
32" Flying Fortress
Ott-O-Former No. 56

No 57
32" Flying Fortress
Ott-O-Former No. 57

No 58
32" Flying Fortress
Ott-O-Former No. 58

No 59
32" Flying Fortress
Ott-O-Former No. 59

No 60
32" Flying Fortress
Ott-O-Former No. 60

No 61
32" Flying Fortress
Ott-O-Former No. 61

No 62
32" Flying Fortress
Ott-O-Former No. 62

No 63
32" Flying Fortress
Ott-O-Former No. 63

No 64
32" Flying Fortress
Ott-O-Former No. 64

No 65
32" Flying Fortress
Ott-O-Former No. 65

No 66
32" Flying Fortress
Ott-O-Former No. 66

No 67
32" Flying Fortress
Ott-O-Former No. 67

No 68
32" Flying Fortress
Ott-O-Former No. 68

No 69
32" Flying Fortress
Ott-O-Former No. 69

No 70
32" Flying Fortress
Ott-O-Former No. 70

No 71
32" Flying Fortress
Ott-O-Former No. 71

No 72
32" Flying Fortress
Ott-O-Former No. 72

No 73
32" Flying Fortress
Ott-O-Former No. 73

No 74
32" Flying Fortress
Ott-O-Former No. 74

No 75
32" Flying Fortress
Ott-O-Former No. 75

No 76
32" Flying Fortress
Ott-O-Former No. 76

No 77
32" Flying Fortress
Ott-O-Former No. 77

No 78
32" Flying Fortress
Ott-O-Former No. 78

No 79
32" Flying Fortress
Ott-O-Former No. 79

No 80
32" Flying Fortress
Ott-O-Former No. 80

No 81
32" Flying Fortress
Ott-O-Former No. 81

No 82
32" Flying Fortress
Ott-O-Former No. 82

No 83
32" Flying Fortress
Ott-O-Former No. 83

No 84
32" Flying Fortress
Ott-O-Former No. 84

No 85
32" Flying Fortress
Ott-O-Former No. 85

No 86
32" Flying Fortress
Ott-O-Former No. 86

No 87
32" Flying Fortress
Ott-O-Former No. 87

No 88
32" Flying Fortress
Ott-O-Former No. 88

No 89
32" Flying Fortress
Ott-O-Former No. 89

No 90
32" Flying Fortress
Ott-O-Former No. 90

No 91
32" Flying Fortress
Ott-O-Former No. 91

No 92
32" Flying Fortress
Ott-O-Former No. 92

No 93
32" Flying Fortress
Ott-O-Former No. 93

No 94
32" Flying Fortress
Ott-O-Former No. 94

No 95
32" Flying Fortress
Ott-O-Former No. 95

No 96
32" Flying Fortress
Ott-O-Former No. 96

No 97
32" Flying Fortress
Ott-O-Former No. 97

No 98
32" Flying Fortress
Ott-O-Former No. 98

No 99
32" Flying Fortress
Ott-O-Former No. 99

No 100
32" Flying Fortress
Ott-O-Former No. 100

Ott-O-Formers Copyrighted

No 3219-32" BOEING FLYING FORTRESS

TRACE CUT LINES WITH SHARP BLADE TO AVOID SPLITTING

No 3219-32" BOEING FORTRESS

A

B

C

D

E

F

G

H

I

J

K

L

M

N

O

P

Q

R

S

T

U

V

W

X

Y

Z