

1/16 Sheet

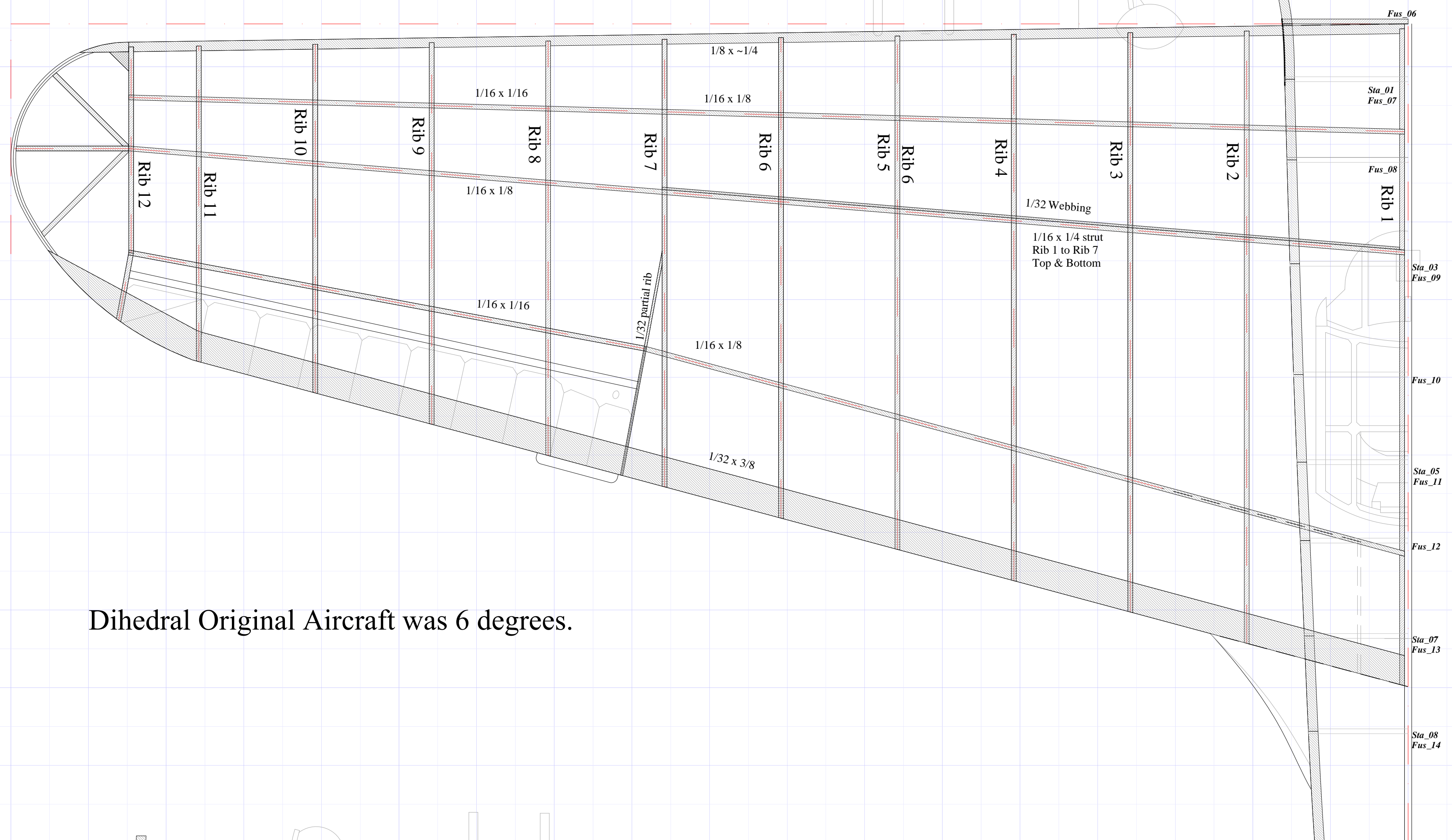

Dihedral Original Aircraft was 6 degrees.

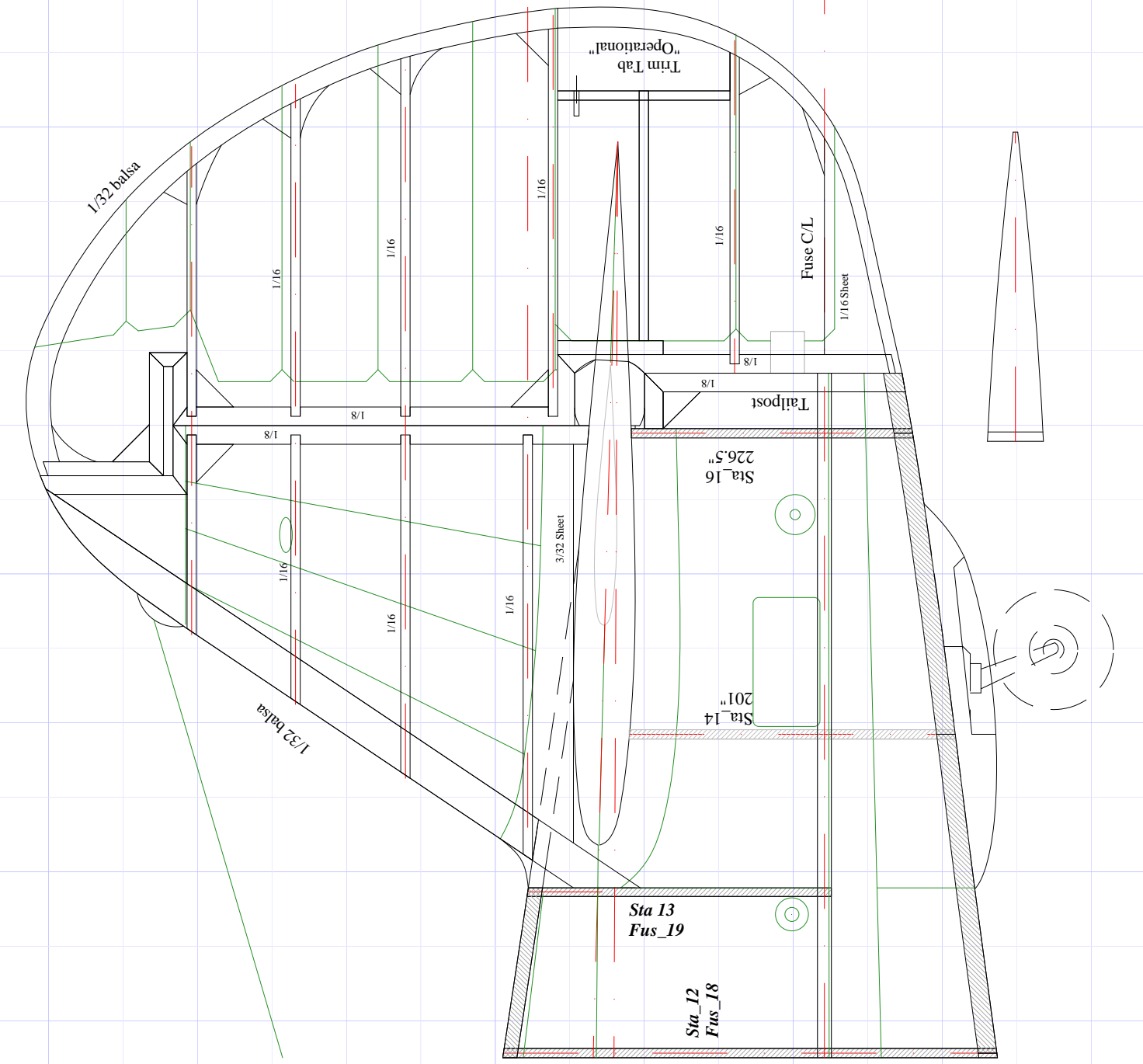
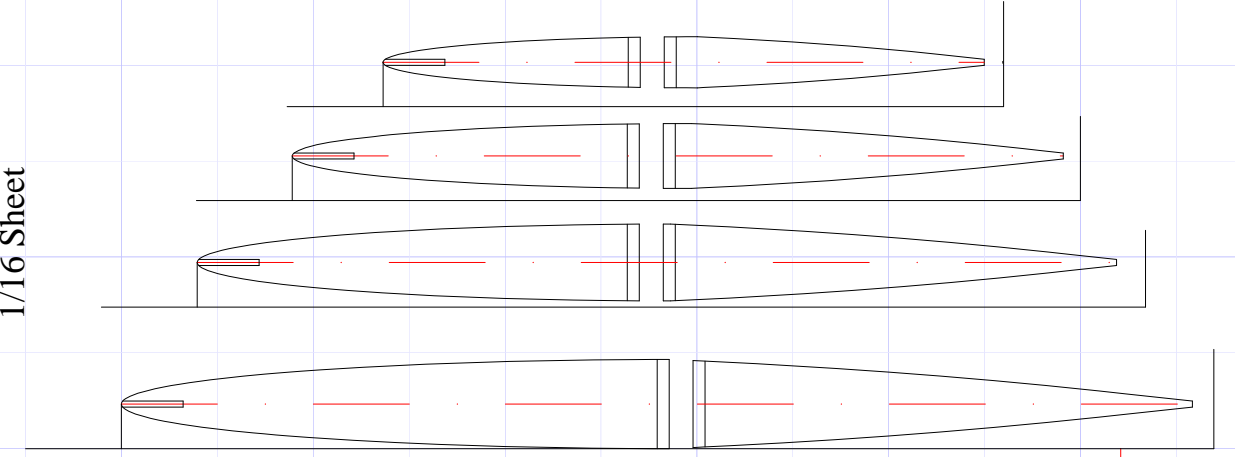
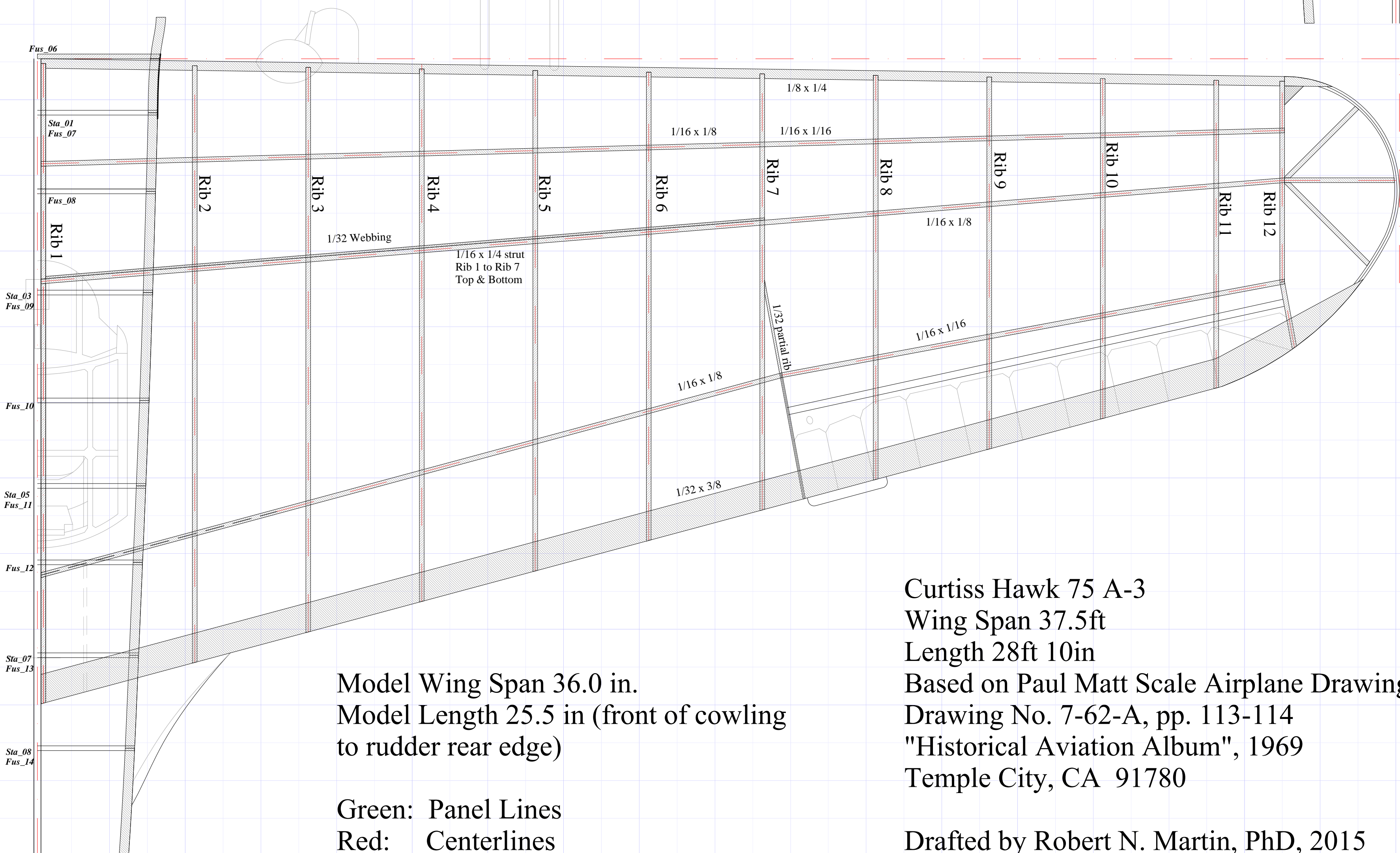

Model Wing Span 36.0 in.
Model Length 25.5 in (front of cowling to rudder rear edge)

Green: Panel Lines
Red: Centerlines

Curtiss Hawk 75 A-3
Wing Span 37.5ft
Length 28ft 10in
Based on Paul Matt Scale Airplane Drawings
Drawing No. 7-62-A, pp. 113-114
"Historical Aviation Album", 1969
Temple City, CA 91780

Drafted by Robert N. Martin, PhD, 2015

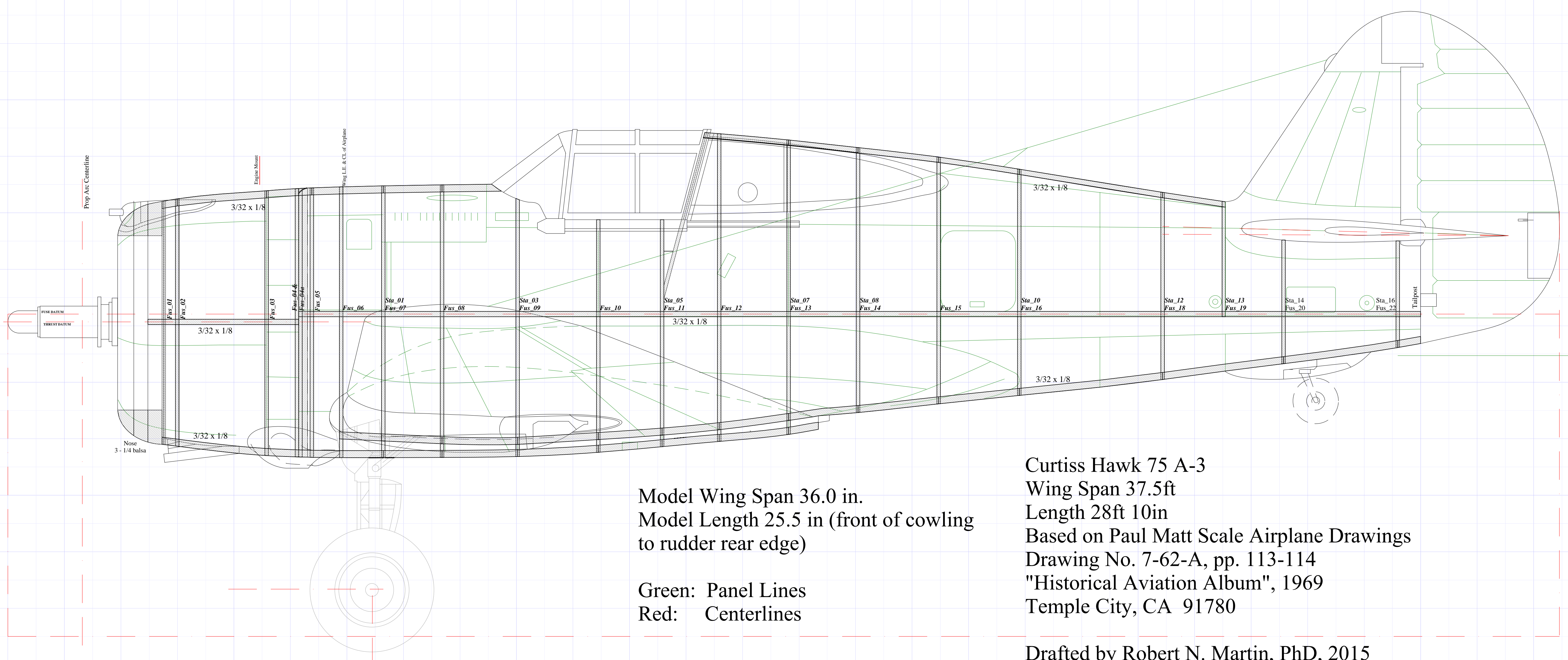
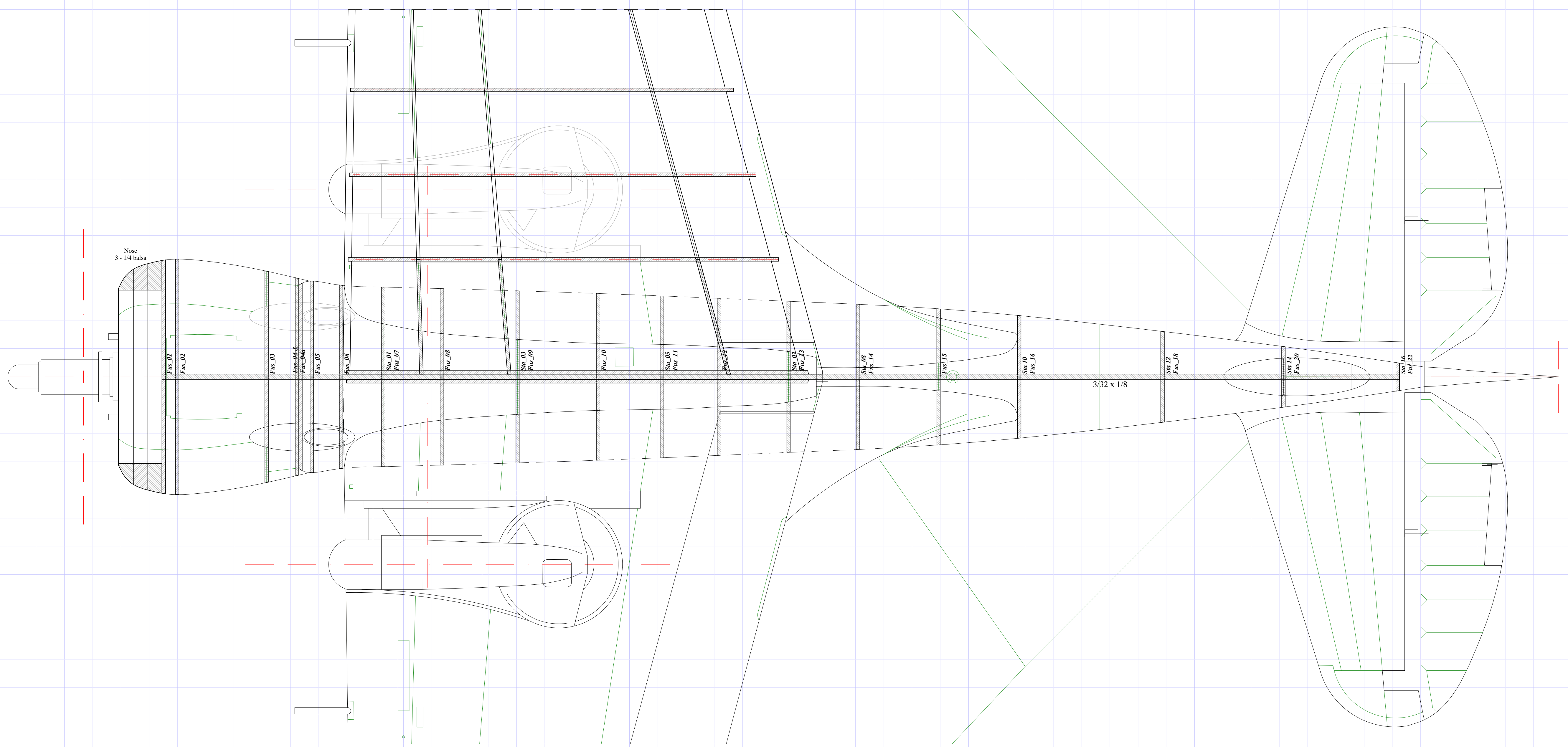

Model Wing Span 36.0 in.
 Model Length 25.5 in (front of cowling
 to rudder rear edge)

Green: Panel Lines
 Red: Centerlines

Curtiss Hawk 75 A-3
 Wing Span 37.5ft
 Length 28ft 10in
 Based on Paul Matt Scale Airplane Drawings
 Drawing No. 7-62-A, pp. 113-114
 "Historical Aviation Album", 1969
 Temple City, CA 91780

Drafted by Robert N. Martin, PhD, 2015

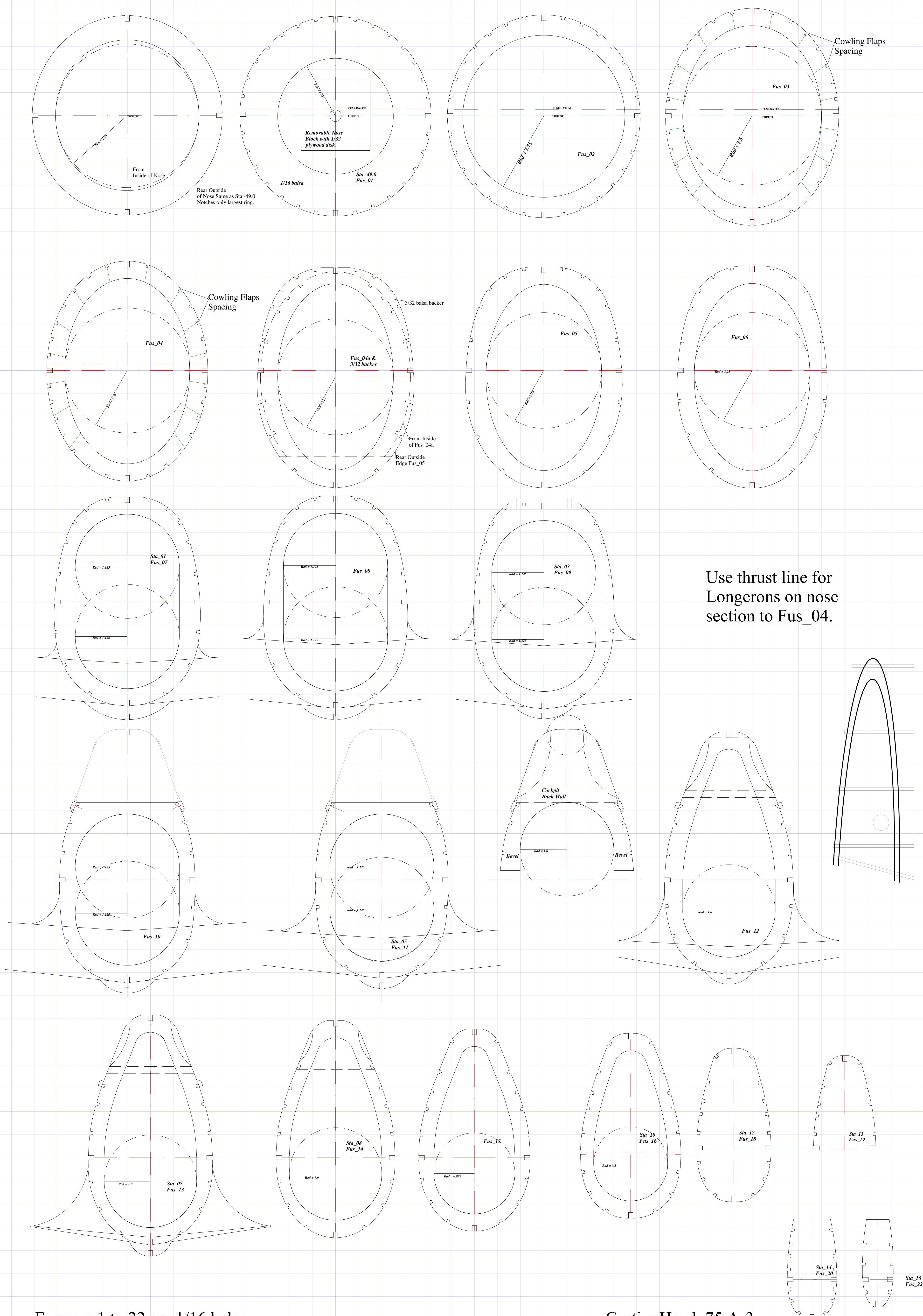

Formers 1 to 22 are 1/16 balsa.
Former 1 is backed-up with 1/32 plywood.

Model Wing Span 36.0 in.
Model Length 25.5 in (front of cowling
to rudder rear edge)

Red: Centerlines

Curtiss Hawk 75 A-3
Wing Span 37.5ft
Length 28ft 10in
Based on Paul Matt Scale Airplane Drawings
Drawing No. 7-62-A, pp. 113-114
"Historical Aviation Album", 1969
Temple City, CA 91780

Drafted by Robert N. Martin, PhD, 2015

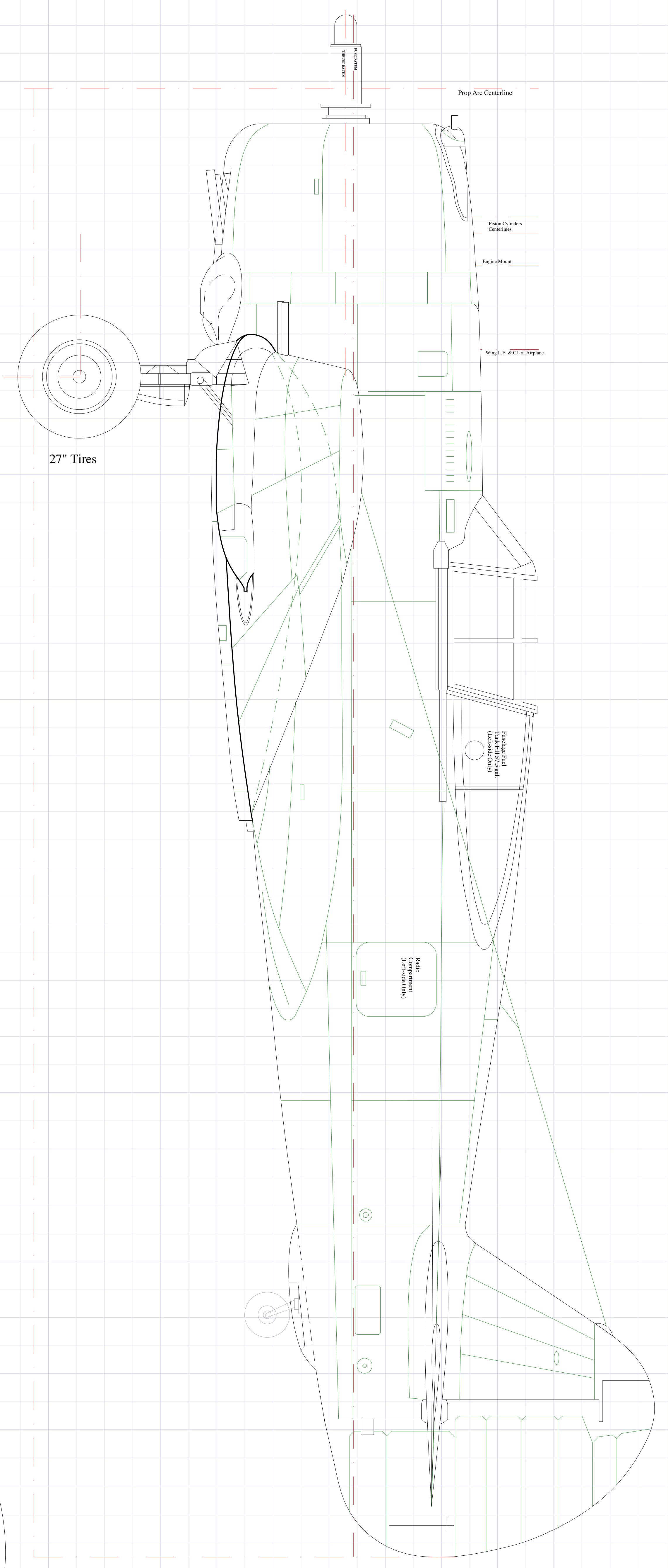
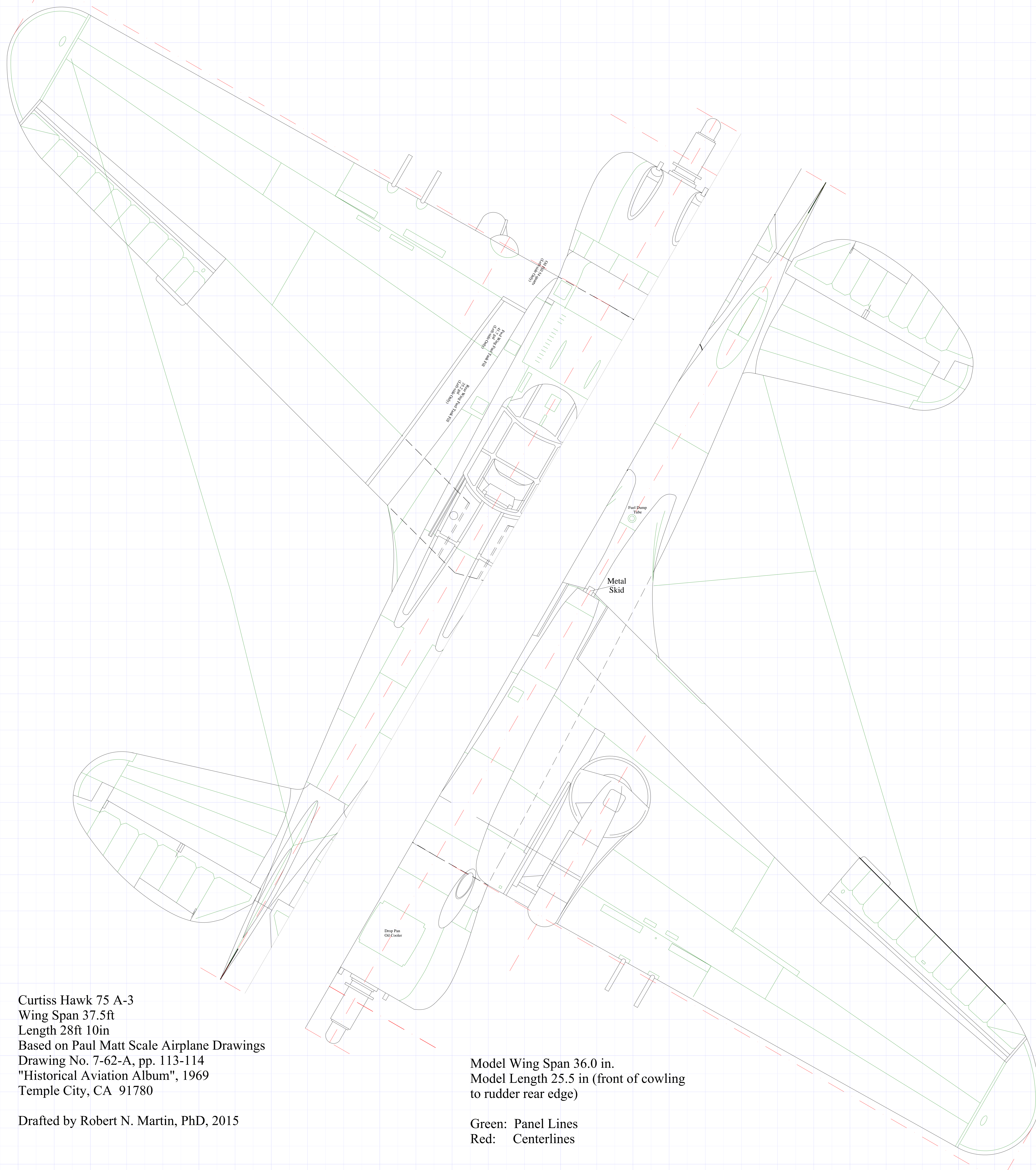

Curtiss Hawk 75 A-3
 Wing Span 37.5ft
 Length 28ft 10in
 Based on Paul Matt Scale Airplane Drawings
 Drawing No. 7-62-A, pp. 113-114
 "Historical Aviation Album", 1969
 Temple City, CA 91780

Model Wing Span 36.0 in.
 Model Length 25.5 in (front of cowling
 to rudder rear edge)

Green: Panel Lines
 Red: Centerlines

Drafted by Robert N. Martin, PhD, 2015

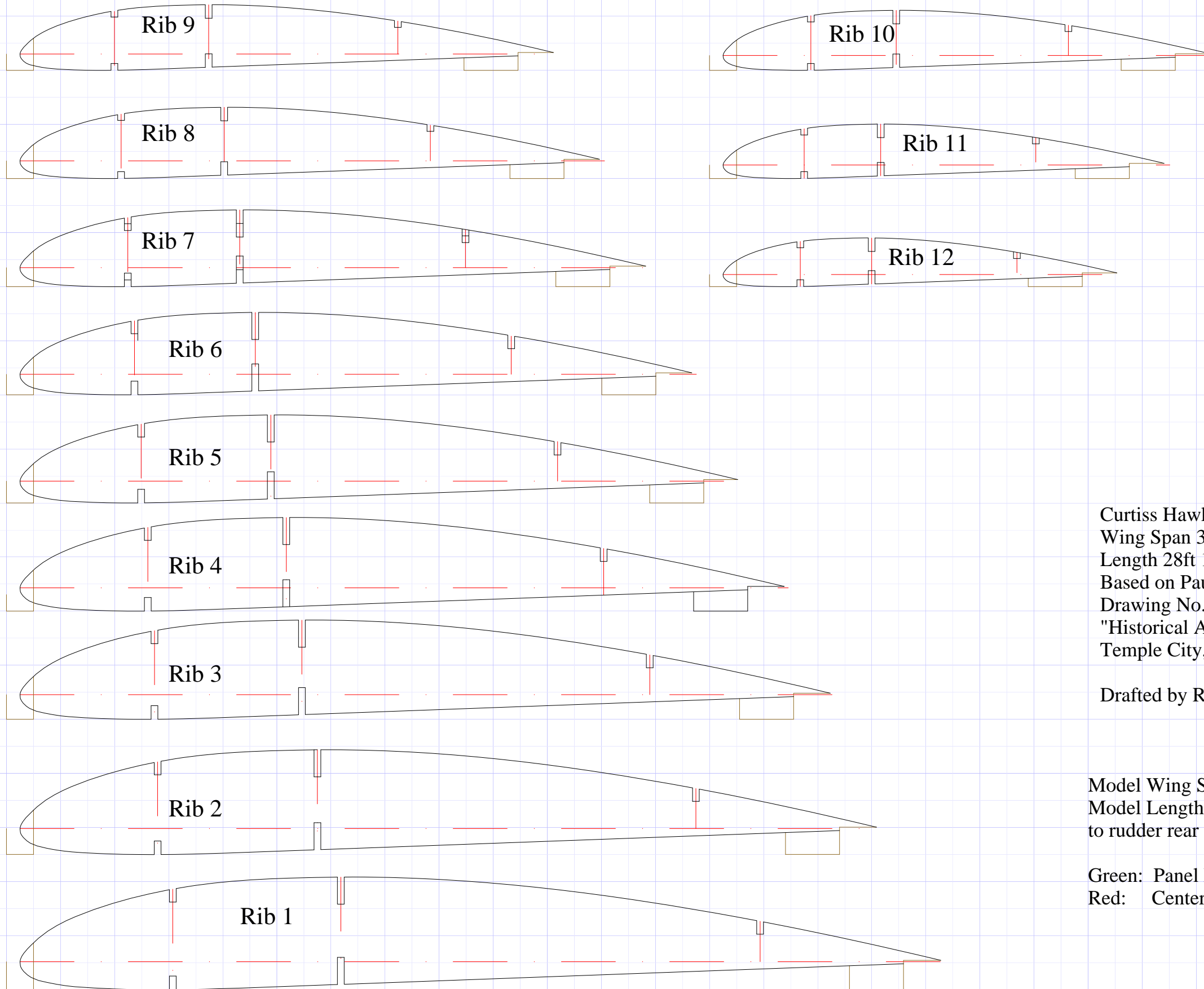

Curtiss Hawk 75 A-3
 Wing Span 37.5ft
 Length 28ft 10in
 Based on Paul Matt Scale Airplane Drawings
 Drawing No. 7-62-A, pp. 113-114
 "Historical Aviation Album", 1969
 Temple City, CA 91780

Drafted by Robert N. Martin, PhD, 2015

Model Wing Span 36.0 in.
 Model Length 25.5 in (front of cowling
 to rudder rear edge)

Green: Panel Lines
 Red: Centerlines