

FLYING SCALE MODEL

of the LOCKHEED HUDSON

SPECIALLY DESIGNED FOR THE

MK. III



BY *H. J. Lowner*

PROTOTYPE MAKERS NO. LOCKHEED 414-56-01
POWERED WITH 2 1,200 HP WRIGHT CYCLONE
G 205 A3, GIVES A MAX. SPEED OF
284 M.P.H. AT 5000 FT.

INSTRUCTIONS:— BUILD COMPLETE
TOP HALF ABOVE FOUNDATION LINE
A3 PER SKETCH USING "BASIC
STRINGERS" AS SUBSTRUCTURE &
ADDING ALL RIBS & STRINGERS
FORMERS "BCDEFG" TO BE PINNED
TO BUILDING BOARD DURING
ABOVE OPERATIONS NOTE "X"
THESE ARE TEMPORARY BINDINGS
TO BE COMPLETED BY "Y" WHEN
TOP HALF IS LIFTED FROM BOARD AND ALL
BOTTOM STRUCTURE ADDED

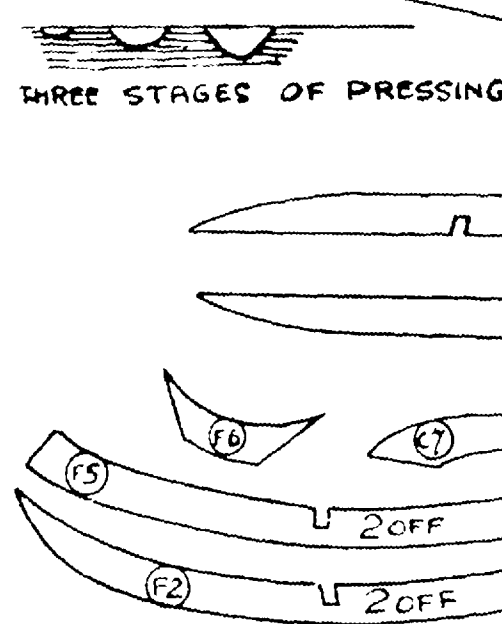
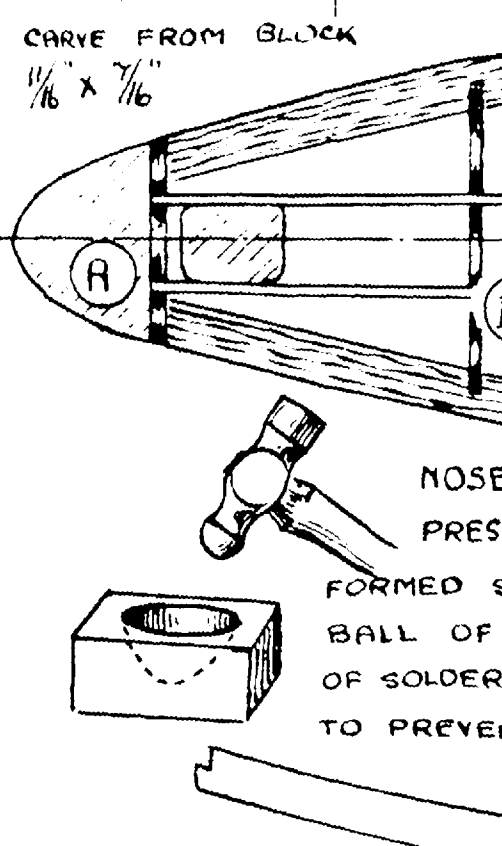
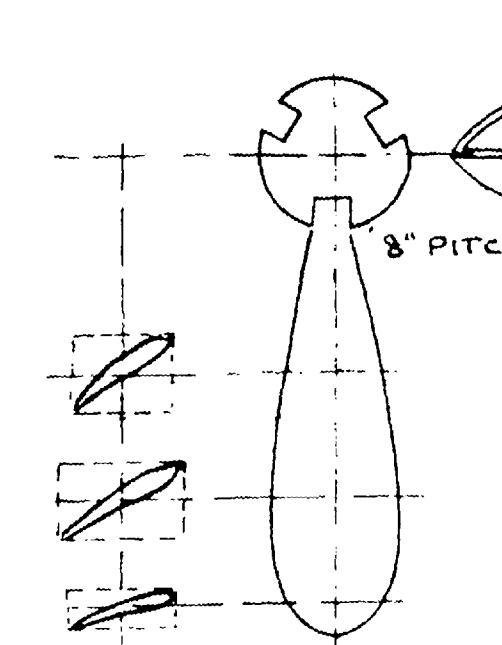
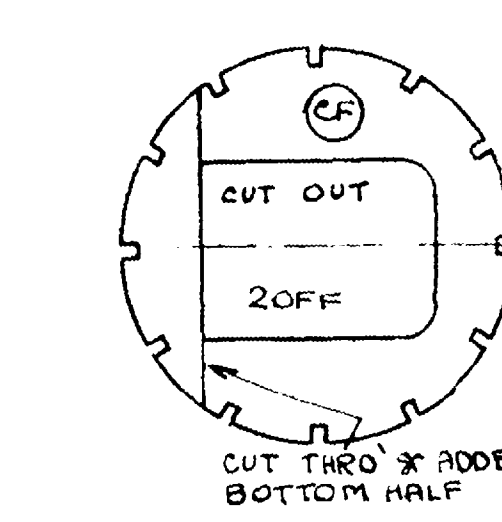
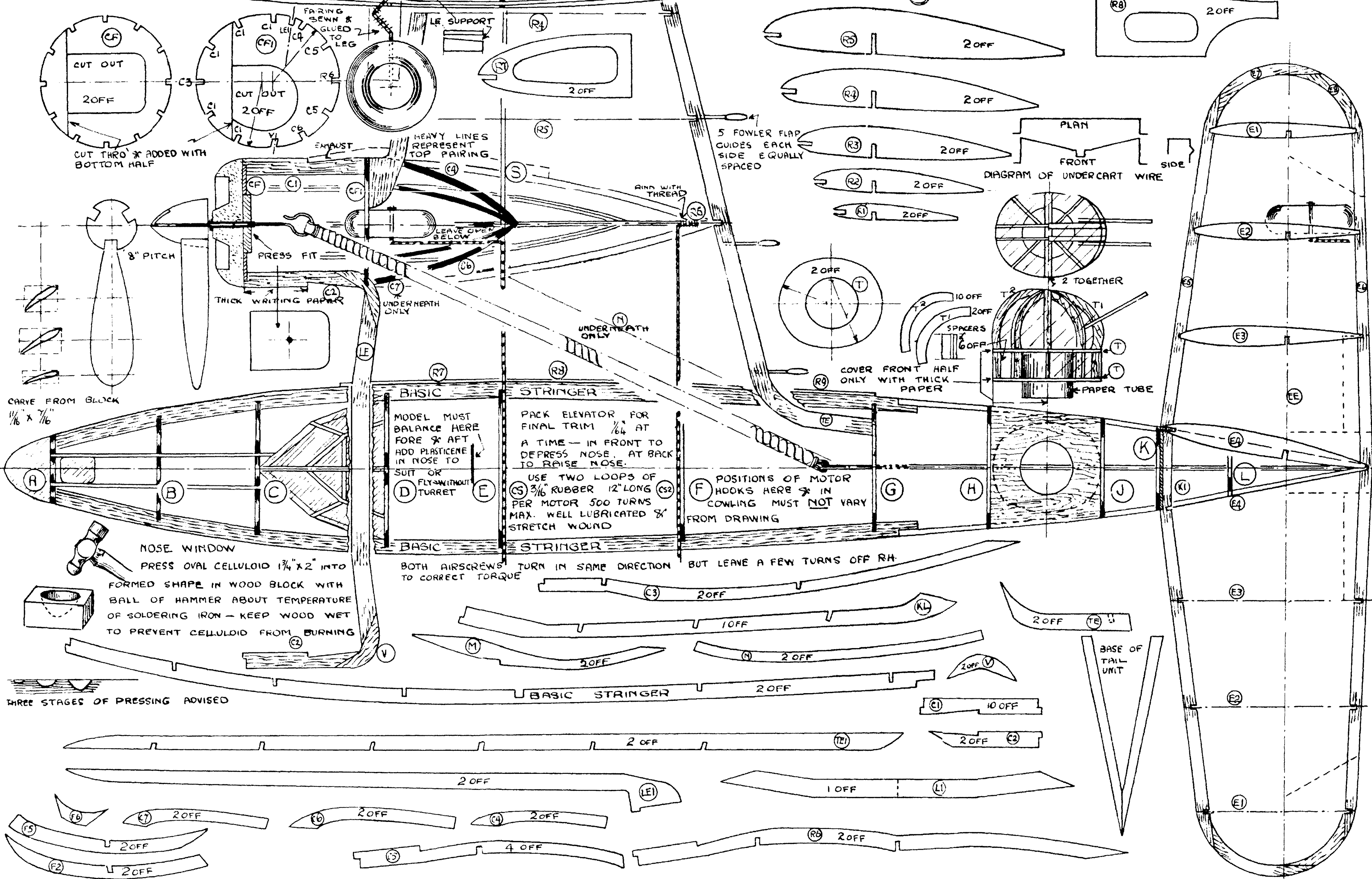
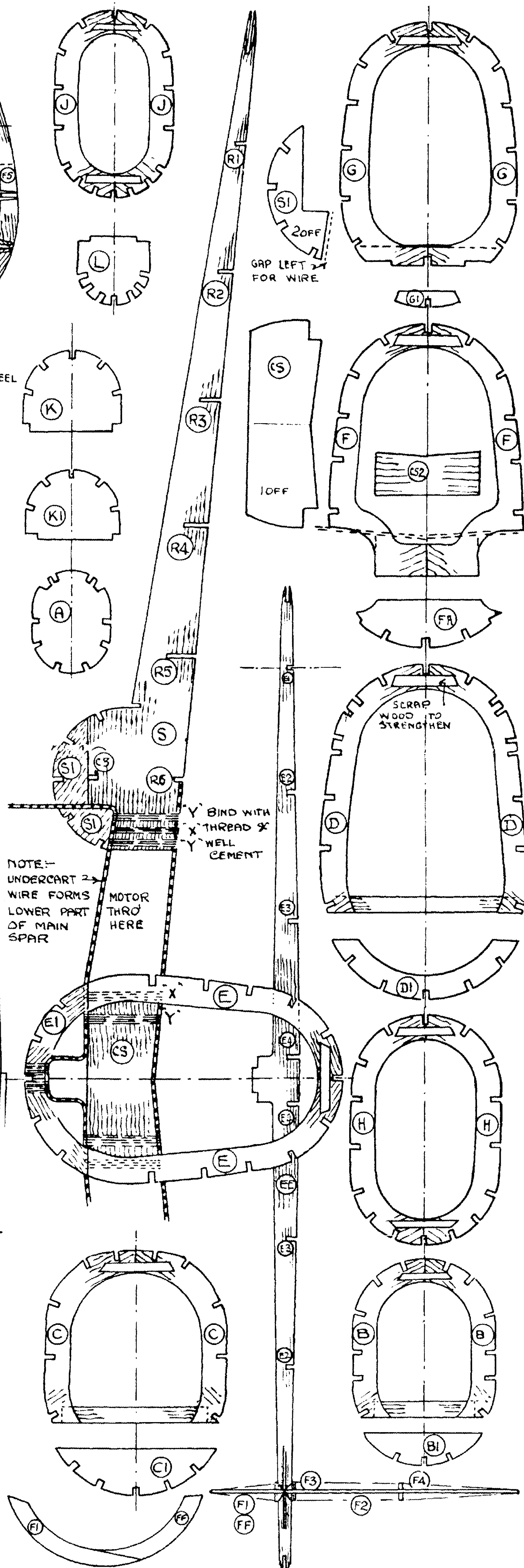
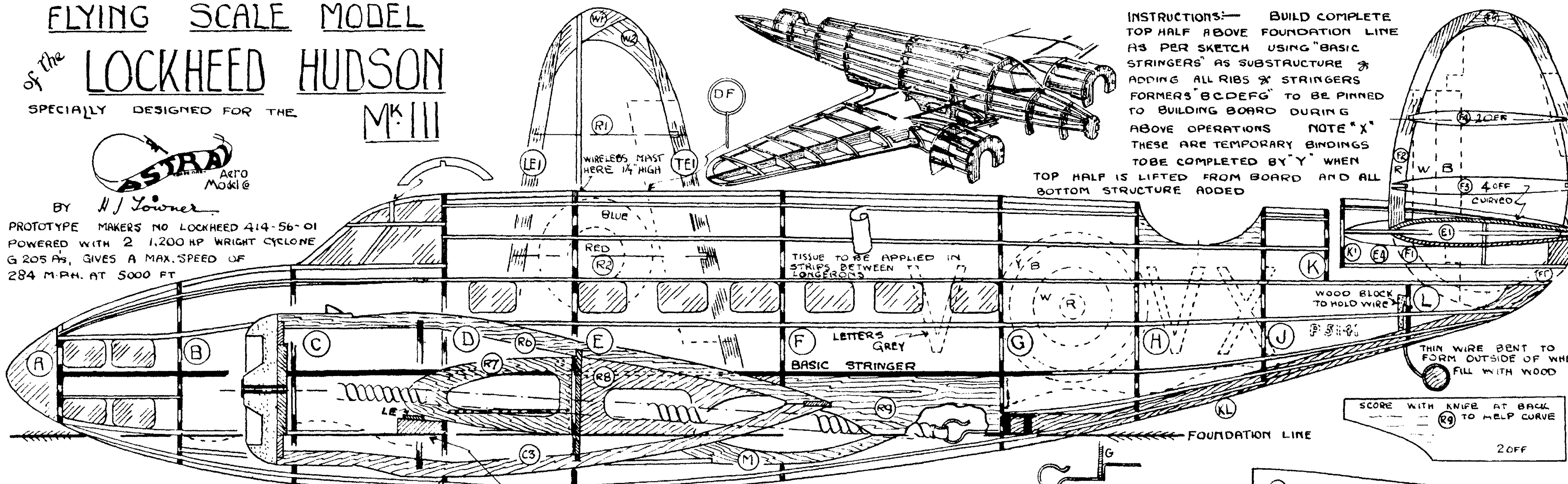

MODEL MUST BALANCE HERE
FORE & AFT
ADD PLASTICINE
IN NOSE TO
SUIT OR
FLY WITHOUT
TURRET

PACK ELEVATOR FOR
FINAL TRIM 1/4" AT
A TIME — IN FRONT TO
DEPRESS NOSE. AT BACK
TO RAISE NOSE.

USE TWO LOOPS OF
3/16" RUBBER 12" LONG
PER MOTOR 500 TURNS
MAX. WELL LUBRICATED 3/4"
STRETCH WOUND

POSITIONS OF MOTOR
HOOKS HERE & IN
COWLING MUST NOT VARY
FROM DRAWING

BOTH AIRSCREWS TURN IN SAME DIRECTION BUT LEAVE A FEW TURNS OFF RH.
TO CORRECT TORQUE

NOSE WINDOW
PRESS OVAL CELLULOID 1 3/4" X 2" INTO
FORMED SHAPE IN WOOD BLOCK WITH
BALL OF HAMMER ABOUT TEMPERATURE
OF SOLDERING IRON — KEEP WOOD WET
TO PREVENT CELLULOID FROM BURNING

THREE STAGES OF PRESSING ADVISED

MODEL MUST BALANCE HERE
FORE & AFT
ADD PLASTICINE
IN NOSE TO
SUIT OR
FLY WITHOUT
TURRET

PACK ELEVATOR FOR
FINAL TRIM 1/4" AT
A TIME — IN FRONT TO
DEPRESS NOSE. AT BACK
TO RAISE NOSE.

USE TWO LOOPS OF
3/16" RUBBER 12" LONG
PER MOTOR 500 TURNS
MAX. WELL LUBRICATED 3/4"
STRETCH WOUND

POSITIONS OF MOTOR
HOOKS HERE & IN
COWLING MUST NOT VARY
FROM DRAWING

BOTH AIRSCREWS TURN IN SAME DIRECTION BUT LEAVE A FEW TURNS OFF RH.
TO CORRECT TORQUE